

# Goulds 3796 *i-FRAME*<sup>™</sup>

Self-Priming Process Pumps  
with Patented Intelligent Monitoring



**ITT**

*Engineered for life*

# Goulds 3796

## Self-Priming Process Pumps Designed for Total Range of Industry Services

- ◆ Capacities to 1250 GPM (284 m<sup>3</sup>/h)
- ◆ Heads to 430 feet (131 m)
- ◆ Temperatures to 500° F (260° C)
- ◆ Pressures to 375 PSIG (2586 kPa)
- ◆ Effective static lift to 20 feet (6 m)

## Performance Features for Self-Priming Services

### ◆ Extended Pump Life

- One-piece casing with integral priming and air separation (no external priming chamber or air separator required)
- No suction check valve required
- Rapid priming time
- Positive retention of pumpage under siphon conditions
- Self-purge of vapors
- *i-FRAME* Power Ends

### ◆ Ease of Maintenance

- Back pull-out design (one craft maintenance)
- Parts interchangeable with Goulds Model 3196
- External impeller adjustment
- Easy retrofit

### ◆ Safety

- ANSI B15.1 coupling guard
- Ductile iron frame adapter
- Fully serrated flanges

## Services

Industrial sump	Mine dewatering
Chemical transfer	Bilge water removal
Coal pile drainage	Tank car unloading
Filter systems	Petroleum transfer
Aircraft fueling	Column bottoms and reflux



Model 3796 *STi*  
(1x1½-6, 1½x1½-8)

Goulds Model 3796 process pump line is specifically designed to provide superior performance for self-priming services of the Chemical Process Industries.



Model 3796 *MTi*  
(2x2-10, 3x3-10, 4x4-10, 3x3-13,  
4x4-13, 6x6-13)

## Reliable Self-Priming Operation

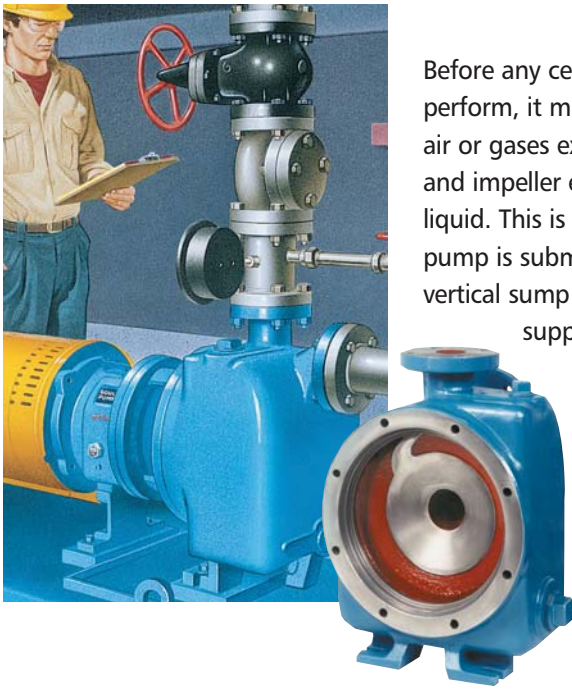

Before any centrifugal pump will perform, it must first be primed; that is, air or gases expelled from the suction and impeller eye area, and replaced with liquid. This is no problem when the pump is submerged (submersible or vertical sump pumps) or when liquid supply is above the pump.

However, when suction pressure is negative, air must be evacuated to accomplish pump priming.

The 3796 is designed to insure that a sufficient quantity of liquid to reprime is always retained in the priming chamber... a compact, integral and completely functional self-priming pump.

The one-piece casing is designed with integral priming and air separation chambers. Priming is accomplished within the casing, eliminating the need for auxiliary priming systems.

### Priming and Air Separation Accomplished Within Casing

Dual volute design primes suction with only an initial charge of liquid in the casing. During priming cycle, the lower volute functions as an intake while upper volute discharges liquid and entrained air into separation chamber. Air is separated and expelled through pump discharge while liquid recirculates into lower volute. Once air is completely removed from suction and liquid fills impeller eye, pump is fully primed, and functions as a conventional centrifugal pump with both volutes performing as discharges.

The casing is designed so that an adequate volume of liquid for repriming is always retained in pump even if liquid is allowed to drain back to source of supply from discharge and suction.

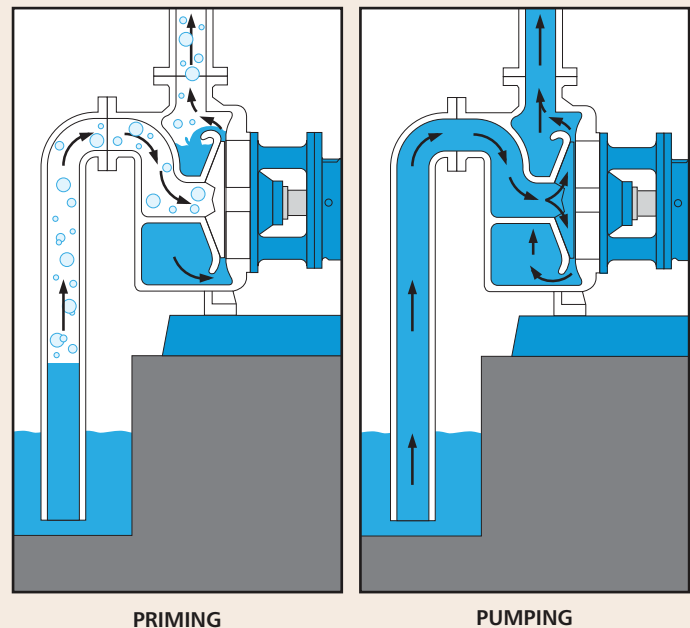

## Interchangeability

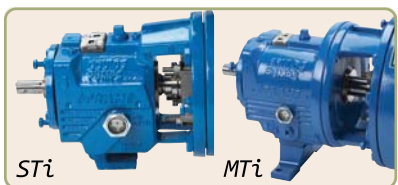

### *i-FRAME*™ Power Ends Fit 7 Different Process Pumps

Minimize inventory, reduce downtime.



**Model 3196**  
*i-FRAME*  
Process Pumps

**Model CV 3196**  
Non-Clog  
Process Pumps

**Model HT 3196**  
High Temperature  
Process Pumps

**Model LF 3196**  
Low Flow ANSI  
Process Pumps

**Model 3198**  
PFA TEFLON®-Lined  
Process Pumps

**Model 3796**  
Self-Priming  
Process Pumps

**Model 3996**  
In-Line Process  
Pumps

## Sealing Solutions

Goulds engineered seal chambers are designed to accept a wide range of sealing arrangements to meet specific user requirements. Your Goulds representative will gladly recommend the best sealing solution for your service... some of which are illustrated here.

### SINGLE INSIDE SEAL (with BigBore™ Seal Chamber)

- Non-corrosive to moderate corrosive liquids
- Moderate abrasives
- Liquids that have good lubrication qualities

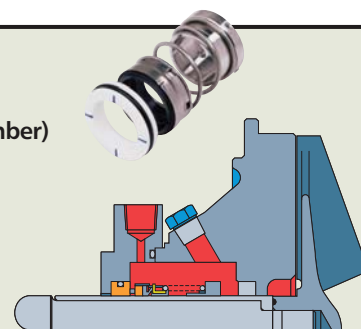

### CONVENTIONAL DOUBLE SEAL (with BigBore™ Seal Chamber)

- Liquids not compatible with single seal
- Toxic, hazardous, abrasive, corrosive
- When pump is operating under cavitation or low flows
- Meet environmental regulations

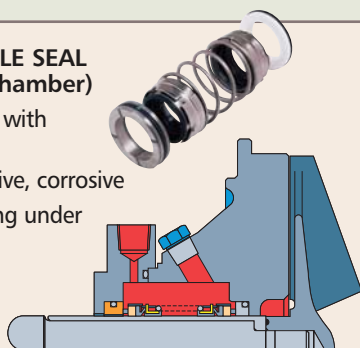

### SINGLE CARTRIDGE SEAL (with TaperBore™ PLUS Seal Chamber)

- Same application as conventional single seal
- Ease of maintenance
- No seal setting problems

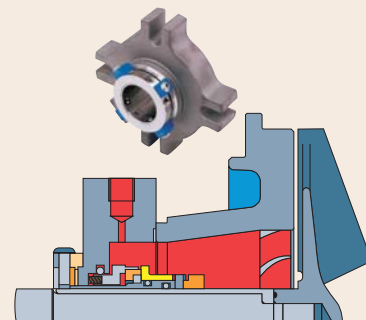

### DOUBLE CARTRIDGE SEAL (with BigBore™ Seal Chamber)

- Same applications as conventional double seal
- Reduced maintenance costs
- No seal setting errors

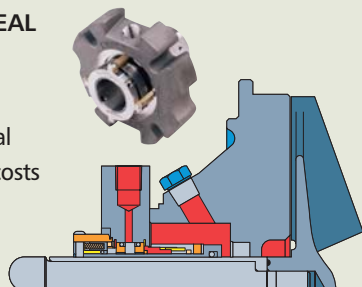

### DOUBLE GAS BARRIER SEAL (with BigBore™ Seal Chamber for Gas Seals)

- Toxic or hazardous liquids
- Meet environmental regulations
- When use of seal pot or external flush is not desirable
- When compatible seal flush liquid not available

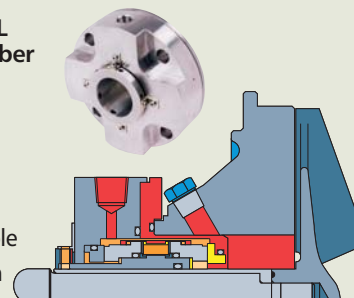

# Hydraulic Coverage

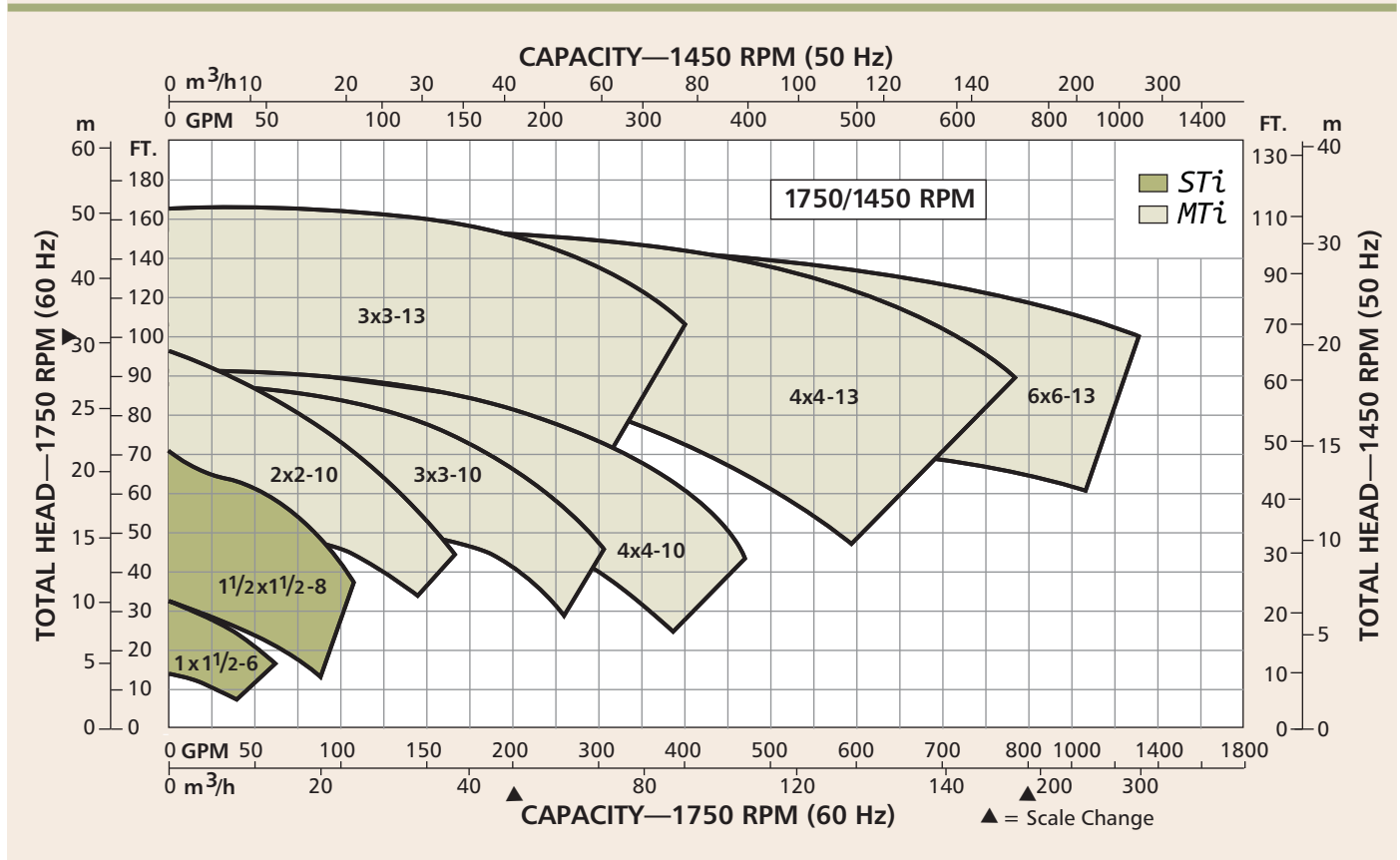
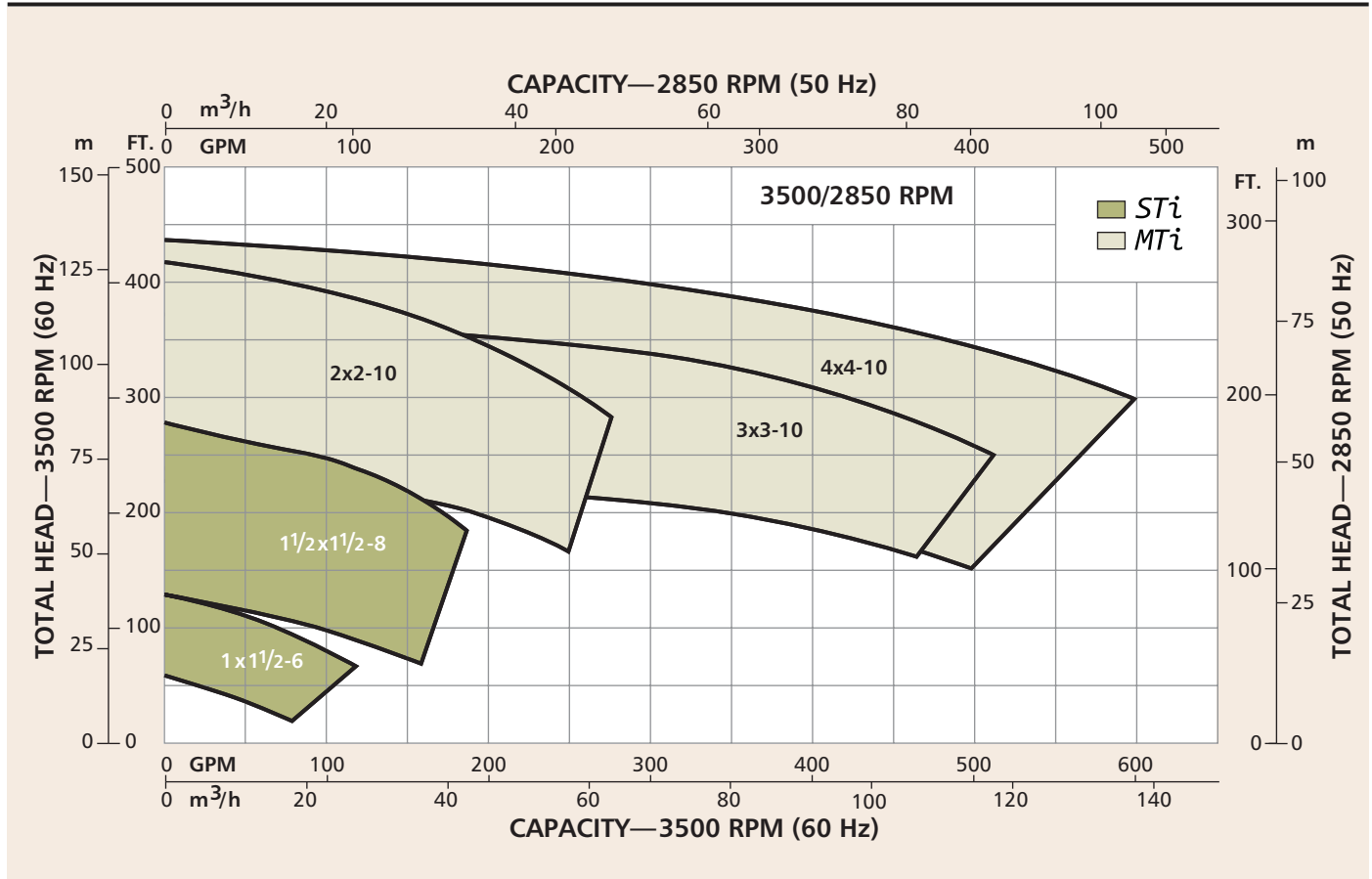





# Model 3796 Self-Priming Process Pumps Featuring i-FRAME Patented Intelligent Monitoring

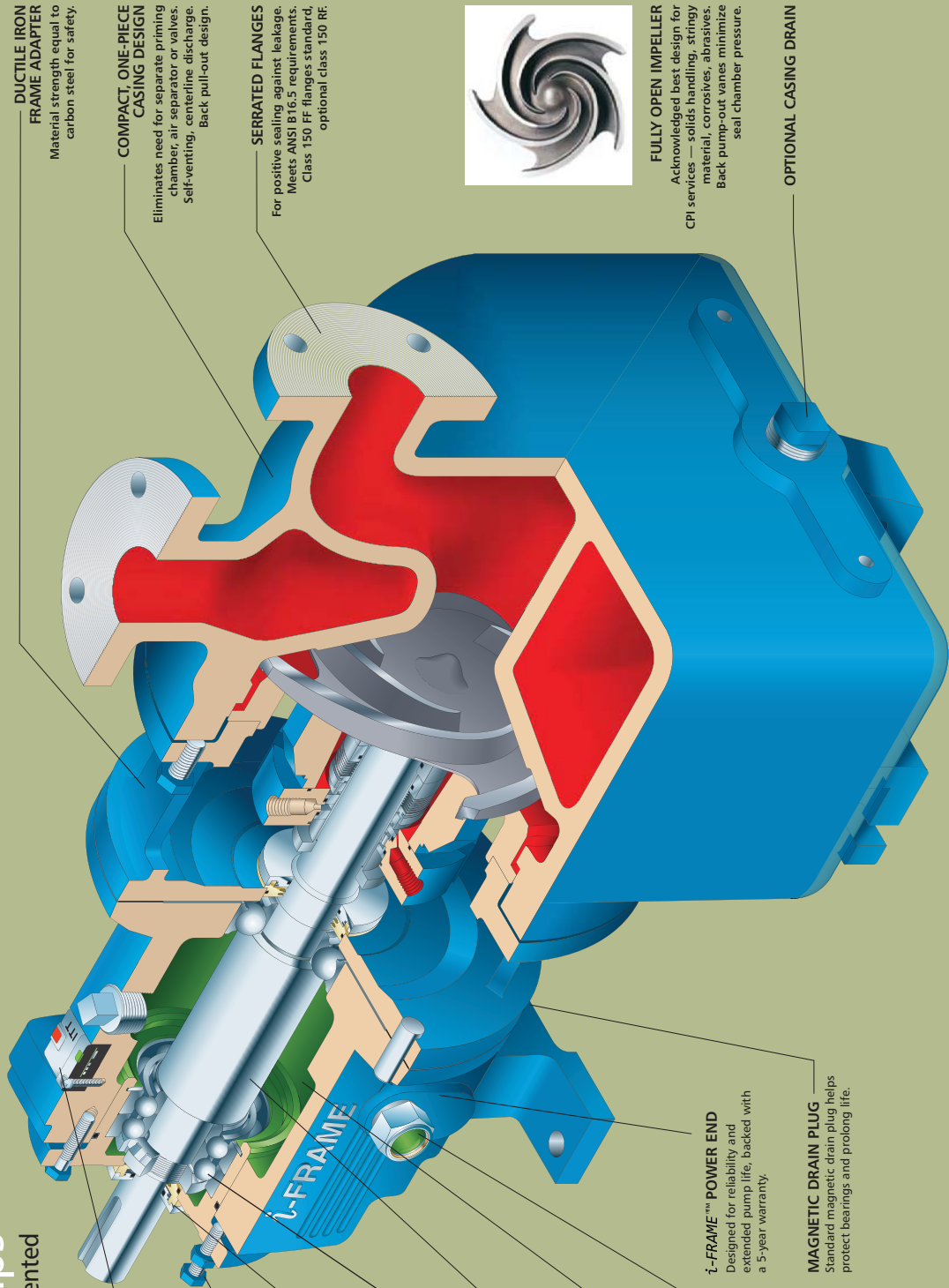

**CONDITION MONITOR**  
(Patent Pending)

Constantly measures vibration and temperature at the thrust bearing. Colored LED's indicate general pump health. Provides early warning of improper operation before catastrophic failure occurs.

**CONTINUOUS PERFORMANCE**

Original flow, pressure and efficiency are maintained by simple external adjustment resulting in long-term energy and repair parts savings.

**INPRO VBXX-D HYBRID LABYRINTH SEALS**

Prevents premature bearing failure caused by lubricant contamination or loss of oil. Stainless steel rotors for optimal performance in corrosive environments.

**PREMIUM SEVERE-DUTY THRUST BEARINGS**

Increase bearing fatigue life by 2-5X that of conventional bearing steels.

**HEAVY DUTY SHAFT AND BEARINGS**

Rigid shaft designed for minimum deflection at seal faces — less than 0.002 in. (.05 mm). Bearings sized for 10-year average life under tough operating conditions. Available with or without shaft sleeve.

**OPTIMIZED OIL SUMP DESIGN**

Increased oil capacity provides better heat transfer for reduced oil temperature. Bearings run cooler and last longer. Contaminants directed away from bearings to magnetic drain plug.

**ONE — INCH BULL'S EYE SIGHT GLASS**

Assures proper oil level critical to bearing life. Can be mounted on either side of pump for installation flexibility.

**DUCTILE IRON FRAME ADAPTER**  
Material strength equal to carbon steel for safety.

**COMPACT, ONE-PIECE CASING DESIGN**  
Eliminates need for separate priming chamber, air separator or valves. Self-venting, centerline discharge. Back pull-out design.

**SERRATED FLANGES**  
For positive sealing against leakage. Meets ANSI B16.5 requirements. Class 150 FF flanges standard, optional class 150 RF



**FULLY OPEN IMPELLER**  
Acknowledged best design for CPI services — solids handling, stringy material, corrosives, abrasives. Back pump-out vanes minimize seal chamber pressure.

**OPTIONAL CASING DRAIN**

**i-FRAME™ POWER END**  
Designed for reliability and extended pump life, backed with a 5-year warranty.

**MAGNETIC DRAIN PLUG**  
Standard magnetic drain plug helps protect bearings and prolong life.

\*E.I. DuPont reg. trademark

# Sectional View Model 3796

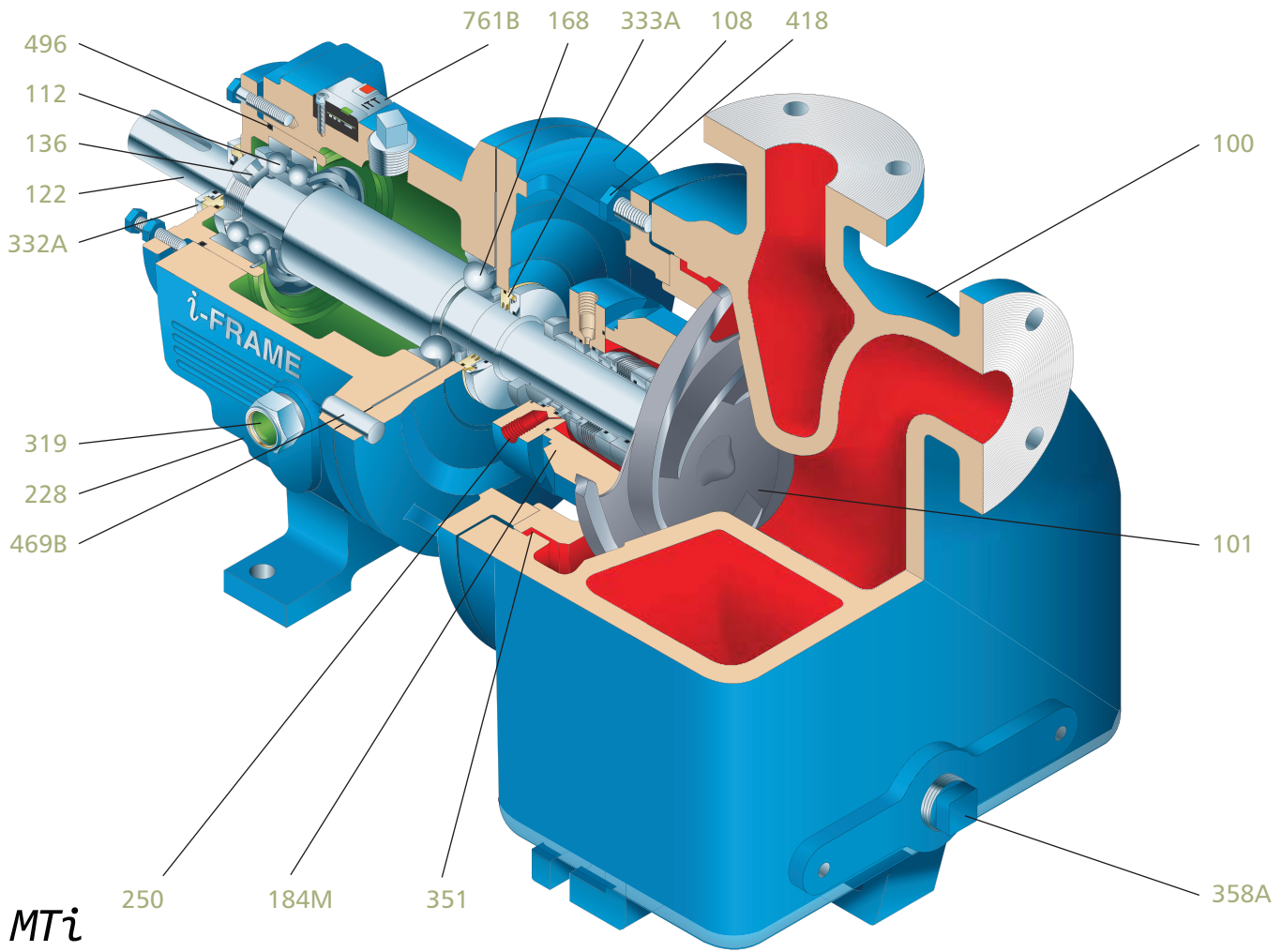

*STi*

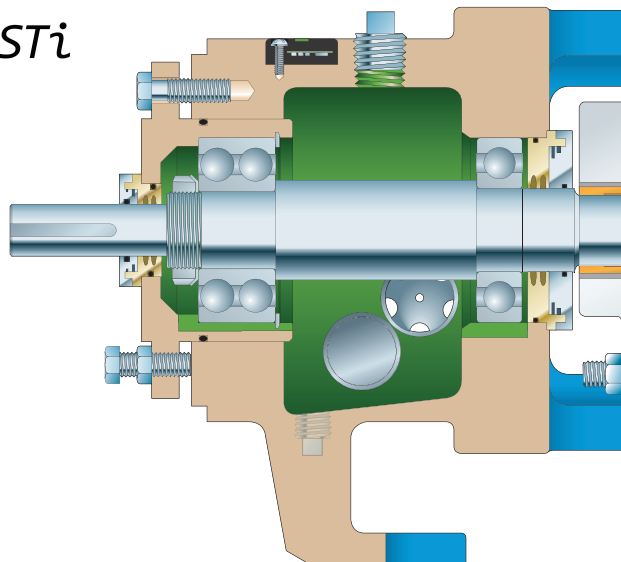

*LTi*

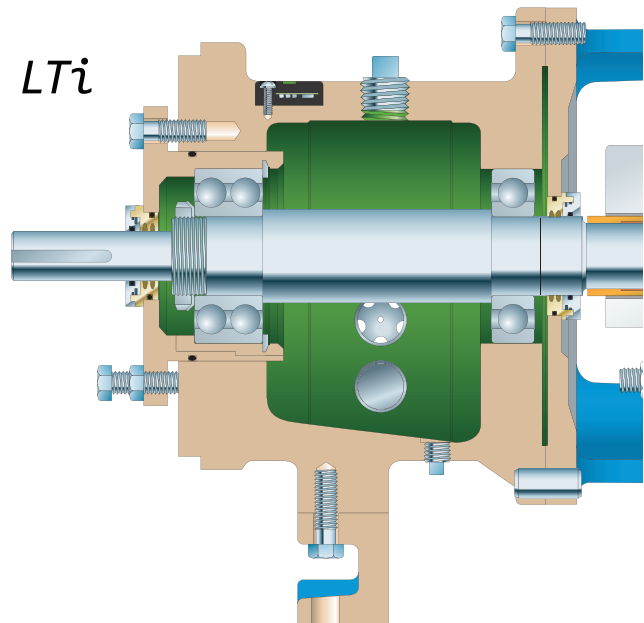

## Parts List and Materials of Construction

Item Number	Part Name	MATERIAL					
		Ductile Iron	316SS	CD4MCu	Alloy 20	Hastelloy B & C	Titanium
100	Casing	Ductile Iron	316SS	CD4MCu	Alloy 20	Hastelloy	Titanium
101	Impeller	Ductile Iron	316SS	CD4MCu	Alloy 20	Hastelloy	Titanium
105	Lantern Ring	Glass-Filled TEFLON*					
106	Stuffing Box Packing	TEFLON* Impregnated Fibers					
108	Frame Adapter***	Ductile Iron					
112	Thrust Bearing	Double Row Angular Contact**					
122	Shaft—Less Sleeve (Optional)	SAE4140	316SS	Alloy 20	Hastelloy	Titanium	
122	Shaft—With Sleeve	SAE4140			316SS		
126	Shaft Sleeve	316SS		Alloy 20		Hastelloy	Titanium
136	Bearing Locknut and Lockwasher	Steel					
168	Radial Bearing	Single Row Deep Groove					
184	Stuffing Box Cover (Packed Box)	Ductile Iron	316SS	CD4MCu	Alloy 20	Hastelloy	Titanium
184M	Seal Chamber (Mechanical Seal)	Ductile Iron	316SS	CD4MCu	Alloy 20	Hastelloy	Titanium
228	Bearing Frame	Cast Iron (Ductile Iron for STi Group)					
250	Gland	316SS		CD4MCu	Alloy 20	Hastelloy	Titanium
262	Repeller/Sleeve (Dynamic Seal Option)	CD4MCu				Hastelloy	Titanium
264	Gasket, Cover to Backplate (Dynamic Seal)	TEFLON*					
265A	Stud/Nut, Cover to Adapter	304SS					
319	Oil Sight Glass	Glass/Steel					
332A	INPRO® VBXX-D Labyrinth Oil Seal (Outboard)	Stainless Steel/Bronze					
333A	INPRO® VBXX-D Labyrinth Oil Seal (Inboard)	Stainless Steel/Bronze					
351	Casing Gasket	Aramid Fiber with EPDM Rubber					
358A	Casing Drain Plug (Optional)	Steel	316SS	CD4MCu	Alloy 20	Hastelloy	Titanium
360	Gasket, Frame-to-Adapter	Buna					
360A	Gasket, Bearing End Cover	Vellumoid					
370	Cap Screw, Adapter-to-Casing	Steel	304SS				
418	Jacking Bolt	304SS					
444	Backplate (Dynamic Seal Option)	Ductile Iron	316SS	CD4MCu	Alloy 20	Hastelloy	Titanium
469B	Dowel Pin	Steel					
496	O-ring, Bearing Housing	Buna Rubber					
496A	O-ring, Impeller	Glass-Filled TEFLON*					
761B	Condition Monitor	Stainless Steel/Epoxy					

\*E.I. DuPont reg. trademark

\*\*LTi Power End features Duplex Angular Contact

\*\*\*Integral with STi frame

## Construction Details All dimensions in inches and (mm).

		STi	MTi	LTi
Shaft	Diameter at Impeller	.75 (19)	1 (25)	1.25 (32)
	Diameter in Stuffing Box/Seal Chamber (Less Sleeve)	1.375 (35)	1.75 (45)	2.125 (54)
		1.125 (29)	1.5 (38)	1.875 (48)
	Diameter Between Bearings	1.5 (38)	2.125 (54)	2.5 (64)
	Diameter at Coupling	.875 (22)	1.125 (29)	1.875 (48)
	Overhang	6.125 (156)	8.375 (213)	8.375 (213)
Maximum Shaft Deflection	0.002 (0.05)			
Sleeve	O.D. thru Stuffing Box/Seal Chamber	1.375 (35)	1.75 (45)	2.125 (54)
Bearings	Radial	SKF 6207	SKF 6309	SKF 6311
	Thrust	SKF 5306 A/C3	SKF 5309 A/C3	SKF 7310 BECBM
	Bearing Span	4.125 (105)	6.75 (171)	6.875 (164)
	Average L <sub>10</sub> Bearing Life	87,600 hours		
BigBore™ Seal Chamber	Bore	2.875 (73)	3.5 (89)	3.875 (98)
Stuffing Box	Bore	2 (51)	2.5 (64)	2.875 (73)
Power Limits	HP (kW) per 100 RPM	1.1 (.82)	3.4 (2.6)	5.6 (4.2)
Maximum Liquid Temperature	Oil/Grease Lubrication without Cooling	350° F (177° C)		
	Oil Lubrication with Finned Cooler	500° F (260° C)		
Casing	Corrosion Allowance	.125 (3)		



# Goulds Patented *i-FRAME*™ Power Ends

## Extended Pump Life Through Intelligent Design

Goulds *i-FRAME* Power Ends are the result of 160 years of design experience, customer interaction, and continuous improvement. Customers get extended Mean Time Between Failure (MTBF) and lower life cycle costs (LCC)... guaranteed!

### 1 Condition Monitor



The heart of the *i-FRAME*, the condition monitor unit continuously measures vibration and temperature at the thrust bearing and automatically indicates when pre-set levels of vibration and temperature have been exceeded, so that changes to the process or machine can be made before failure occurs.

A visual indication of pump health makes walk-around inspections more efficient and accurate. The result is a more robust process to monitor and maintain all your ANSI pumps so that your plant profitability is maximized.

A reliability program centered around walk-arounds captures equipment condition on average once a month; the failure process, however, can begin and end quite frequently within this time period.

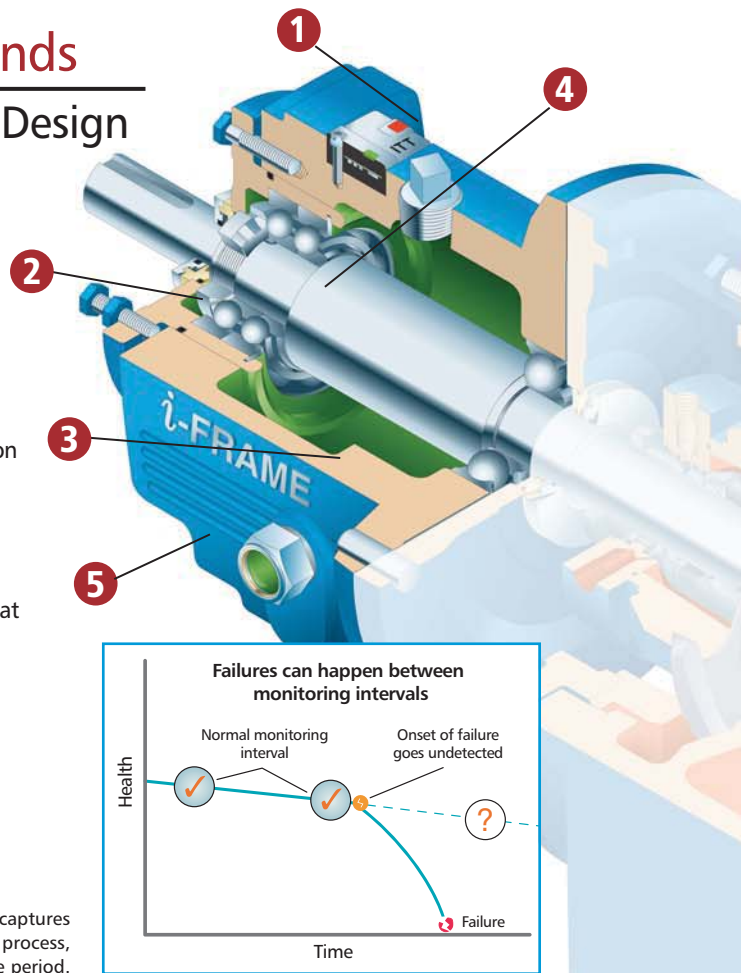

### 2 Inpro VBXX-D Hybrid Bearing Isolators

Most bearings fail before reaching their potential life. They fail for a variety of reasons, including contamination of the lubricant. INPRO VBXX-D has long been considered the industry standard in bearing lubricant protection. The *i-FRAME* now improves upon that design by offering stainless steel rotors, for maximum protection against contaminants and the corrosive effects of seal leakage or environmental conditions. These seals are non-contacting and do not wear.

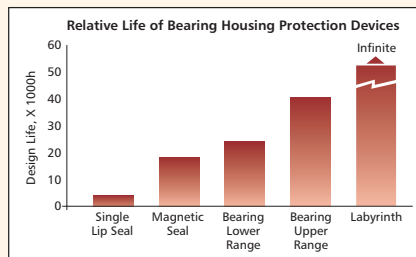

### 3 Optimized Oil Sump Design

Internal sump geometry is optimized for longer bearing life. Sump size increased by 10%-20% results in better heat transfer and cooler bearings. Contoured design directs contaminants away from bearings, to the magnetic drain plug for safe removal.

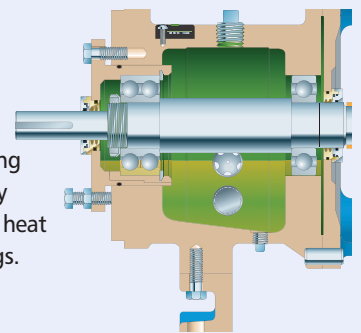

Larger Means Cooler  
 ■ GOULDS  
 ■ Industry Average

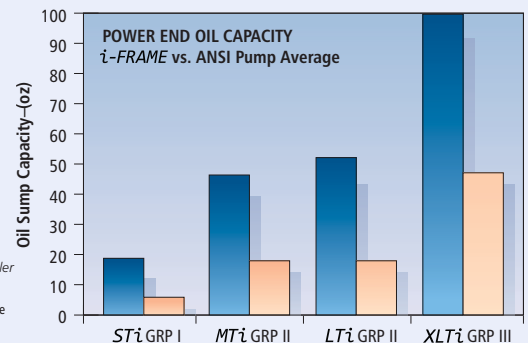

## 4 Shaft and Bearings Engineered for Maximum Reliability



Fatigue life **more than double** that of conventional bearing steels.

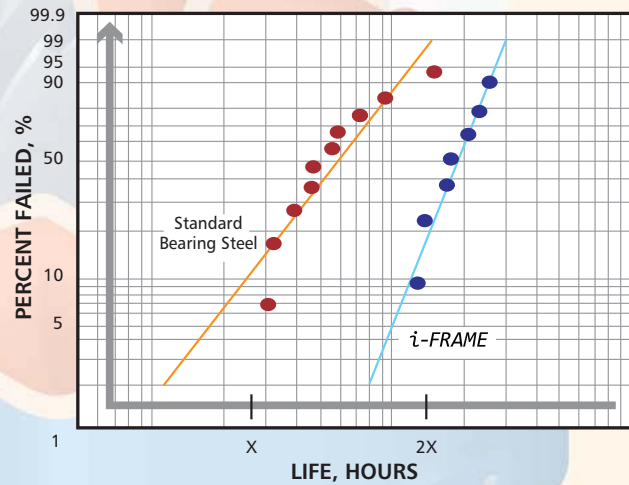

Every model 3796 Power End is engineered and manufactured for optimal pump performance and increased MTBF.

ANSI B73.1 Shaft Specification	Meets	Exceeds
Diameter Tolerance		✓
Surface Finish		✓
Runout	✓	
Deflection		✓

The rugged shaft and bearing combination maintains shaft deflection of less than 0.002 inches at all operating points. The result is longer seal and bearing life.

Premium severe-duty thrust bearings increase bearing fatigue life by 2-5X.

- High purity steels have fewer inclusions than standard steel — better grain structure and wear resistance.
- Heat treatment of bearing elements increases hardness for increased fatigue life.

Forty-degree contact angle on the *MTi* thrust bearing for higher thrust load capability.

- 35% higher dynamic load rating vs. major competitor.
- Increases L'10 bearing life 2X.

BEARING LIFE CALCULATION

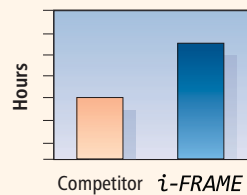

## 5 *LTi* Power End for High Load Applications

Increased L'10 Bearing Life 150% to 200% on the Toughest Applications

Ideal for tough conditions when a power end is pushed beyond ANSI limits: operating at low flows and higher heads, pumping high specific gravity liquids, fluctuating process conditions, overhung belt drive.

Oversized shaft and bearing assembly significantly expands the limits for long, trouble-free bearing and seal life. On high load applications, the *LTi* power end improves bearing life 150%–200%; oil operating temperature reduced by 45°F (25°C).



Duplex thrust bearings (40°/40° angular contact) with machined brass cages, are ideally sized for high load applications.



Oversized shaft with duplex thrust bearings provide increased L'10 by 40%.

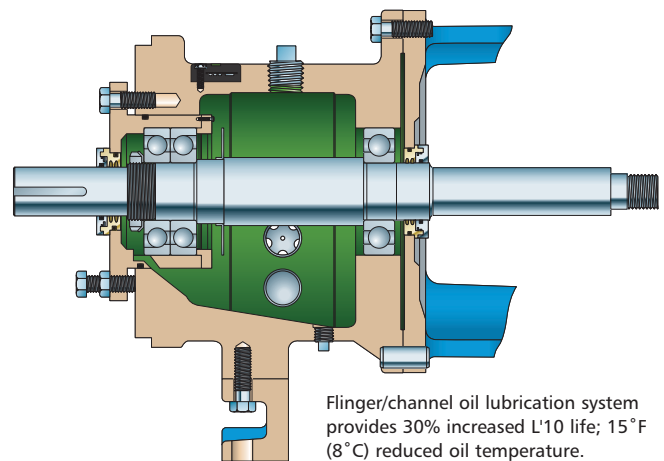

Flinger/channel oil lubrication system provides 30% increased L'10 life; 15°F (8°C) reduced oil temperature.

## Our Guarantee

We are so confident that the *i-FRAME* is the most reliable Power End in the industry, that we are proud to offer a standard 5-year warranty on every *i-FRAME* ANSI Process Pump.



# Dimensions Model 3796

All dimensions in inches and (mm). Not to be used for construction.

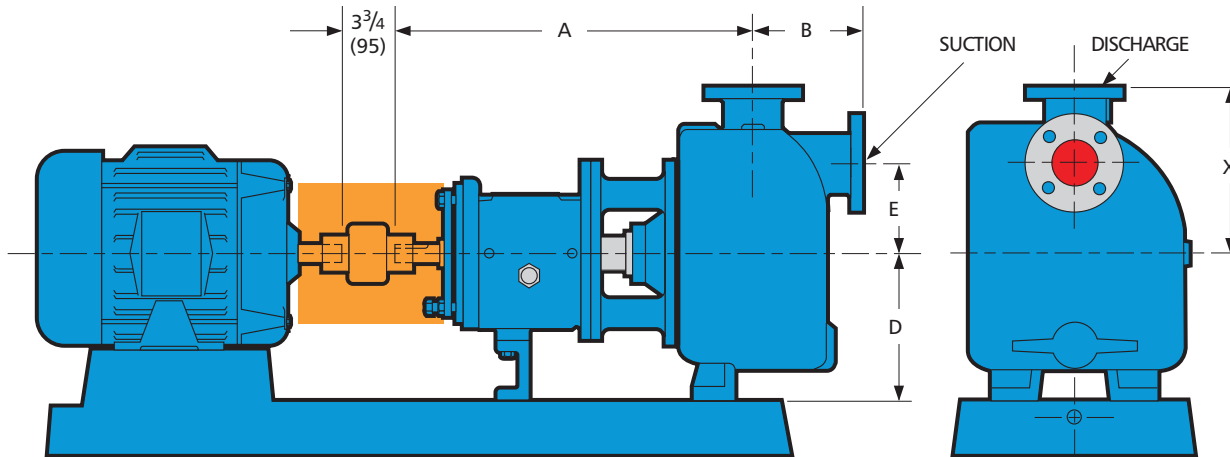

DIMENSIONS									
Group	Pump Size	Discharge	Suction	A	B	D	E	X	Bare Pump Weight Lbs. (kg)
STi	1x1 1/2-6	1	1 1/2	15 1/2 (394)	5 (127)	7 1/2 (191)	4 (102)	7 1/4 (184)	170 (77)
	1 1/2x1 1/2-8	1 1/2	1 1/2					7 7/8 (200)	
MTi	2x2-10	2	2	21 3/4 (552)	6 1/2 (165)	10 (254)	6 (152)	10 (254)	270 (123)
	3x3-10	3	3	22 5/8 (575)	6 3/4 (171)				315 (143)
	4x4-10	4	4	23 3/8 (594)	9 3/16 (233)				370 (168)
	3x3-13	3	3	22 5/8 (575)	6 3/4 (171)			11 1/2 (292)	400 (182)
	4x4-13	4	4	23 3/8 (594)	9 3/16 (233)				470 (214)
	6x6-13	6	6	15 1/4 (387)	10 (254)				14 (356)

## Baseplate Mounting Options

Goulds offers a complete range of mounting systems to meet plant reliability requirements, and to make alignment and maintenance easier.

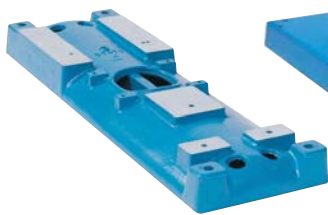

**CAMBER TOP CAST IRON**  
Rigid and corrosion resistant, it is preferred by many plants.

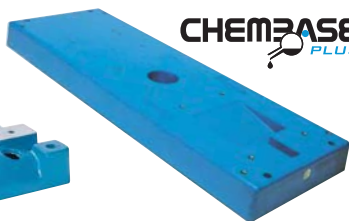

**CHEMBASE PLUS™**  
Polymer concrete construction provides exceptional rigidity & corrosion resistance. ANSI 1991 dimensional.



**FABRICATED STEEL**  
Economical baseplate that meets ANSI/ASME B73.1 M current edition dimensional requirements.

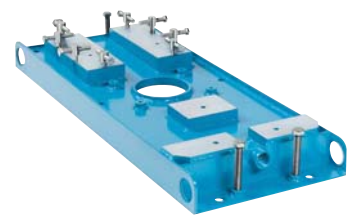

**ENHANCED FEATURE FABRICATED STEEL**  
Upgraded ANSI baseplate designed to maximize pump operation life and ease installation by meeting API-minded chemical pump users toughest requirements.



Visit our Web site at [www.gouldspumps.com](http://www.gouldspumps.com)

