

IOM

INSTALLATION OPERATION
& MAINTENANCE

PDT038 - PDT200

3/8, 1/2, 1, 1-1/2 AND 2 INCH
PULSATION DAMPENERS

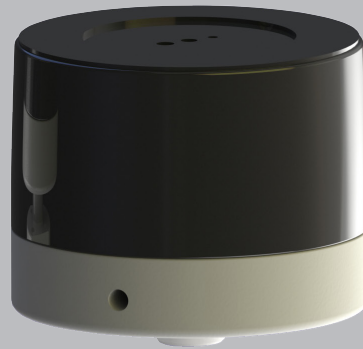
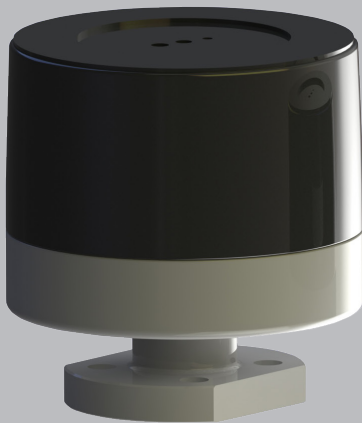

TABLE OF CONTENTS

SECTION 1	WARNINGS, DANGERS AND CAUTIONS	3
SECTION 2	MODEL DESIGNATION MATRIX	4
SECTION 3	DIMENSIONAL DRAWINGS	5
SECTION 4	INSTALLATION, MAINTENANCE	6
SECTION 5	EXPLODED VIEWS AND PARTS LISTS	8-11

CAUTIONS — READ FIRST!

READ THESE WARNINGS AND SAFETY PRECAUTIONS PRIOR TO INSTALLATION OR OPERATION. FAILURE TO COMPLY WITH THESE INSTRUCTIONS COULD RESULT IN PERSONAL INJURY AND OR PROPERTY DAMAGE. RETAIN THESE INSTRUCTIONS FOR FUTURE REFERENCE.

⚠ WARNING This product can expose you to chemicals including Nickel, Chromium, Cadmium, or Cobalt, which are known to the State of California to cause cancer and/or birth defects or other reproductive harm. For more information, go to www.P65Warnings.ca.gov.

⚠ WARNING Pump, valves and all containers must be properly grounded prior to handling flammable fluids and/or whenever static electricity is a hazard.

⚠ WARNING Prior to servicing the pump, ensure that the air and fluid lines are closed and disconnected. While wearing personal protective equipment, flush, drain and process liquid from the pump in a safe manner.

⚠ WARNING The temperature marking refers to the maximum surface temperature depending not on the equipment itself, but mainly on operating conditions. In this case, the maximum surface temperature depends upon the temperature of the process fluids.

⚠ CAUTION Material temperature limits is as follows:

Conductive Polyethylene:	158°F (70°C)
Conductive PTFE:	176°F (80°C)

Temperature limits are solely based upon mechanical stress and certain chemicals will reduce the maximum operating temperature. The allowable temperature range for the process fluid is determined by the materials in contact with the fluid being pumped. Consult a chemical resistance guide for chemical compatibility and a more precise safe temperature limit. Always use minimum air pressure when pumping at elevated temperatures.

⚠ CAUTION Do not lubricate air supply.

⚠ CAUTION Do not connect a compressed air source to the exhaust port of the pump.

⚠ WARNING Use only with liquid process fluid.

⚠ WARNING Maintenance must not be performed when a hazardous atmosphere is present.

⚠ CAUTION Do not exceed 100 psig (7 bar) air-inlet pressure.

⚠ WARNING = Hazards or unsafe practices which could result in severe personal injury, death or substantial property damage

⚠ CAUTION = Hazards or unsafe practices which could result in minor personal injury, product or property damage.

⚠ CAUTION Do not operate with a positive suction pressure.

⚠ CAUTION Ensure all wetted components are chemically compatible with the process fluid and the cleaning fluid.

⚠ CAUTION Ensure pump is thoroughly cleaned and flushed prior to installation into a process line.

⚠ CAUTION Always wear Personal Protective Equipment (PPE) when operating pump.

⚠ CAUTION Close and disconnect all compressed air and bleed all air from the pump prior to service. Remove all process fluid in a safe manner prior to service.

⚠ CAUTION Blow out all compressed air lines in order to remove any debris, prior to pump installation. Ensure that the muffler is properly installed prior to pump operation.

⚠ CAUTION Ensure air exhaust is piped to atmosphere prior to a submerged installation or nitrogen gas installation.

⚠ CAUTION Ensure all hardware is set to correct torque values prior to operation.

MODEL DESIGNATION MATRIX

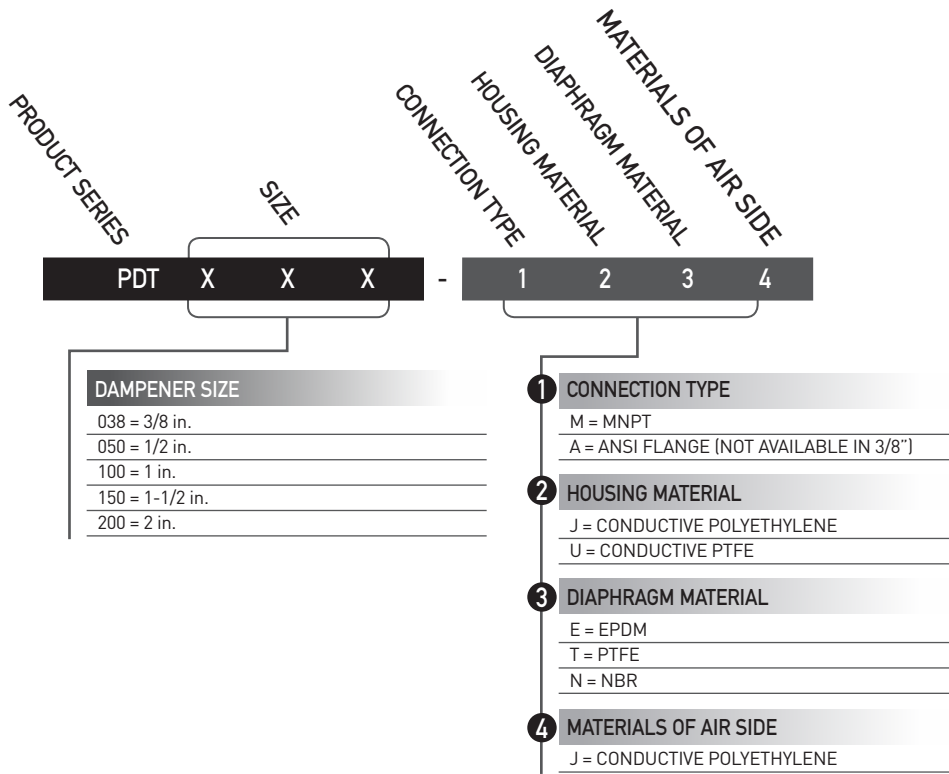

PULSATION DAMPENER DIMENSIONS

MNPT CONNECTION

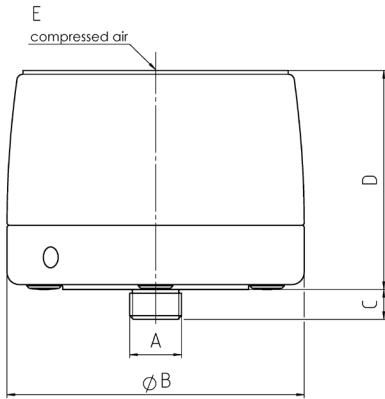

inch (mm)	A	B	C	D	E
PDT038	MNPT 3/8"	3.3 (85)	0.4 (11)	3.1 (79)	FNPT 1/8"
PDT050	MNPT 1/2"	4.7 (120)	0.5 (12)	3.5 (89)	FNPT 1/8"
PDT100	MNPT 1"	6.7 (170)	0.6 (14)	5.2 (133)	FNPT 1/8"
PDT150	MNPT 1-1/2"	8.7 (220)	0.6 (16)	6.4 (162)	FNPT 1/4"
PDT200	MNPT 2"	11.2 (285)	0.7 (18)	8.7 (222)	FNPT 1/4"

ANSI FLANGE CONNECTION

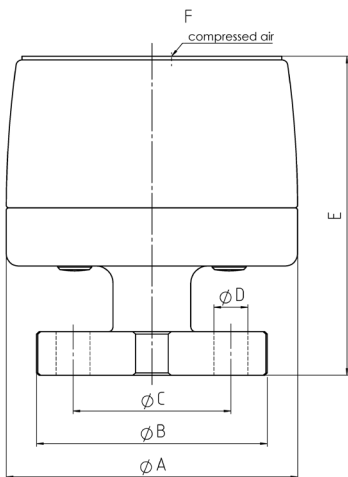

inch (mm)	A	B	C	D	E	F
PDT050	4.7 (120)	3.5 (88.9)	2.4 (60.5)	0.6 (14)	5.2 (132)	FNPT 1/8"
PDT100	6.7 (170)	4.3 (108)	3.1 (79.2)	0.6 (14)	6.9 (176)	FNPT 1/8"
PDT150	8.7 (220)	5 (127)	3.9 (98.6)	0.6 (14)	8.5 (215)	FNPT 1/4"
PDT200	11.2 (285)	6 (152.4)	4.8 (120.7)	0.7 (18)	11.0 (280)	FNPT 1/4"

INSTALLATION, MAINTENANCE

All PDT-dampers are made of conductive plastic materials and may therefore be used for flammable liquids as well as for applications in explosion protected areas as long as grounding is ensured. In case the damper has no conductive connection to a grounded pump, the damper has to be grounded on its own.

The All-Flo damper can only be attached to the discharge side of a pump at a distance as small as possible; a direct connection to the discharge of the pump – e.g. via a T-piece - is ideal. The installation position can be chosen variably, however, it has to be ensured, that no air locks can occur in the liquid chamber of the damper.

In general, any pulsation damper has to be connected load free and has to be supported to avoid tension from the damper onto the pump. Neglecting this causes leakage and maybe even damages. The operator is responsible for an adequately stability and an appropriate fixation of the piping according to the state of the art.

Before connecting the pump, take the yellow blind plugs out of air inlet which is located on the top of the damper head [3]. For correct operation, the damper absolutely needs an air-supply of its own, which has to be taken from the air-supply of the pump. Pump and pulsation damper have to be connected to the same air pressure. No stop or regulating valve may be placed between pump and damper. The driving air has to be oil-free, dry and clean. The damper requires a minimum counter pressure of at least 1 bar for optimal function. Together with the pump an empty damper has to be driven slowly. The dampers are self-regulating for all changing operating conditions.

SUGGESTED INSTALLATION

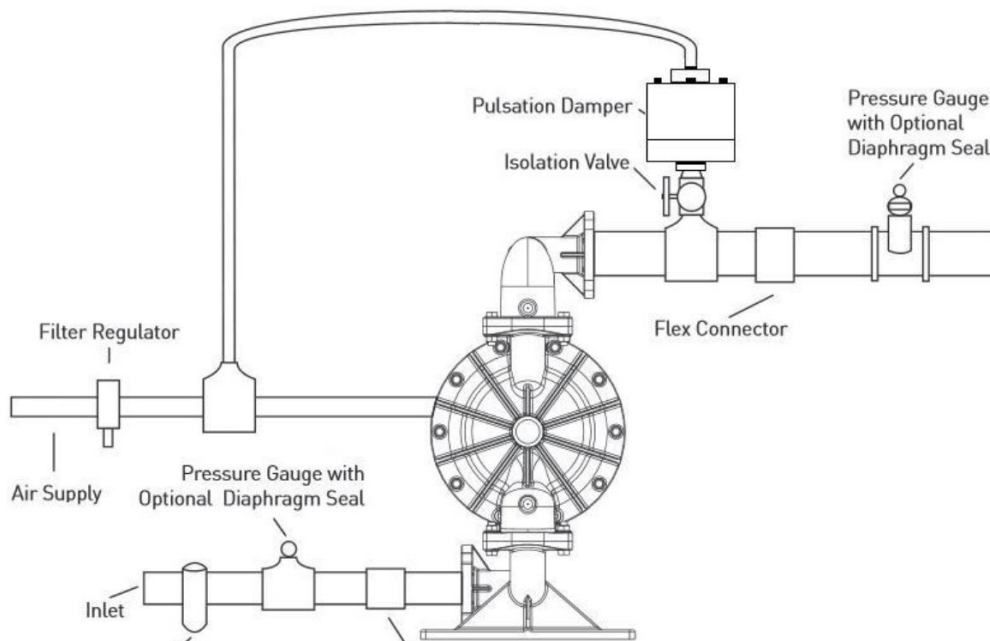

This illustration is a generic representation of an air operated double-diaphragm pump.

SAFETY INSTRUCTIONS

- Do not use any threadseal for the connection of pump and damper, otherwise the threads could be damaged.
- Before putting the pulsation damper into operation as well as after some hours of operating, the housing bolts [6] have to be tightened according to the torque data of the following schedule, as the elements of construction tend to “settle”. Fixing the bolts is necessary as well after longer periods of stoppage, at extreme temperature variations, transport and after dismantling.
- Pressure tests of the plant a pump and a damper are included in may only be carried out with the aggregate (pump and damper) disconnected from the pressure on both ports or by using the pressure the aggregate develops while operating. The load of a pressure in the plant may damage the pump and the pulsation damper.
- Before starting to disassemble the pump, take care that pump and damper have been emptied and rinsed. Further both have to be cut off from any energy on the air and product side. If pump and damper is being deported from the plant, a reference about the delivered liquid has to be attached.
- Please respect the relevant additional security advices, if the pump and the damper have been used for aggressive, dangerous or toxic liquids.
- Before putting the pump and the damper back into operation, the tightness of both has to be checked.
- For further warning instructions, please refer to the page 3.

DISASSEMBLY

Pull out the cover [5]. Unscrew housing bolts [6] carefully. After that, all parts can be removed. Screw the diaphragm [2] off the actuator shaft [7]. A re-assembly of used piston rings [8] is impossible; they have to be replaced including the O-rings underneath. In the well of the actuator shaft [7] are five grooves of which is in the first, third and fifth a piston ring. To assemble new piston rings [8] carefully shape them like kidneys with locking ring pliers and insert the rings into the grooves; completely press the rings into the grooves smoothly using some round tool.

TORQUE VALUES

Torque values for the housing bolts of both versions:

Size	Torque Value ft lbs (Nm)	
	PE	PTFE
PDT038	-	1.5 (2)
PDT050	2.2 (3)	2.2 (3)
PDT100	4.4 (6)	4.4 (6)
PDT150	7.4 (10)	7.4 (10)
PDT200	8.1 (11)	8.1 (11)

Torque values for the flange-screws of ANSI Flange Connection Dampers:

Size	Torque Value ft lbs (Nm)	
	PE	PTFE
PDT050	3 (4)	3 (4)
PDT100	3.7 (5)	3.7 (5)
PDT150	12 (8.9)	12 (8.9)
PDT200	11.1 (15)	11.1 (15)

EXPLODED VIEW & PARTS LIST

MNPT CONNECTION

Pos. / Item 6:
PDT038 / PDT050 - 4x
PDT100 / PDT150 - 6x
PDT200 - 8x

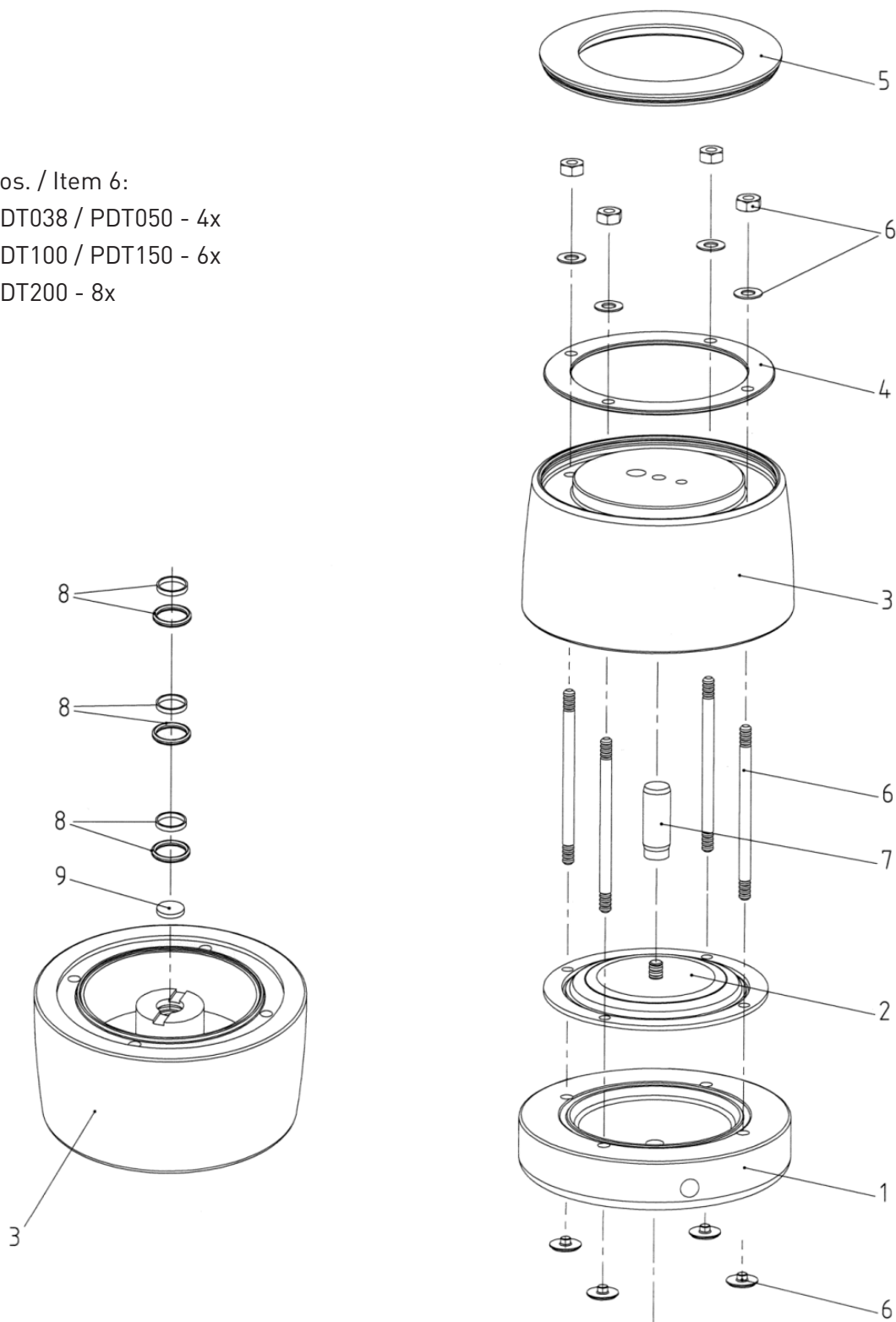

PARTS LIST - MNPT CONNECTION

PUMP SIZE				PDT038	PDT050	PDT100	PDT150	PDT200
ITEM	PC.	DESCRIPTION	MATERIAL	PART NUMBER				
1	1	DAMPENER HOUSING MATERIAL J	CONDUCTIVE PE	-	7 15 080 56	7 25 080 56	7 40 080 56	7 50 080 56
		DAMPENER HOUSING MATERIAL U	CONDUCTIVE PTFE	7 10 080 68	7 15 080 68	7 25 080 68	7 40 080 68	7 50 080 68
2	1	DIAPHRAGM E	EPDM	-	1 10 031 72	1 15 031 72	1 25 031 72	1 40 031 72
		DIAPHRAGM T	PTFE	1 08 031 67	1 10 031 67	1 15 031 67	1 25 031 67	1 40 031 67
		DIAPHRAGM N	NBR	-	1 10 031 70	1 15 031 70	1 25 031 70	1 40 031 70
3	1	MATERIALS OF AIR SIDE J	CONDUCTIVE PE	7 10 081 55	7 15 081 55	7 25 081 55	7 40 081 55	7 50 081 55
4	1	TENSION DISC	1.4301	7 08 008 22	7 10 008 22	7 15 008 22	7 25 008 22	7 40 008 22
5	1	COVER	CONDUCTIVE PE	7 08 009 55	7 10 009 55	7 15 009 55	7 25 009 55	7 40 009 55
6	*	HOUSING BOLT, CPL.	1.4301	7 10 083 22	7 15 083 22	7 25 083 22	7 40 083 22	7 50 083 22
7	1	ACTUATOR SHAFT	1.4301	1 08 482 22	1 10 482 22	1 15 482 22	1 25 482 22	1 40 482 22
8	3	SHAFT PISTON RING, CPL.	PTFE	1 08 041 64	1 08 041 64	1 15 041 64	1 25 041 64	1 40 041 64
9	1	MUFFLER	PE	1 08 644 51	1 08 644 51	1 15 644 51	1 25 644 51	1 40 644 51
*PDT038 AND PDT050: 4 PIECES, PDT100 AND PDT150: 6 PIECES, PDT200 8 PIECES								

EXPLODED VIEW & PARTS LIST

ANSI FLANGE CONNECTION

Pos. / Item 6:
PDT050 - 4x
PDT100 / PDT150 - 6x
PDT200 - 8x

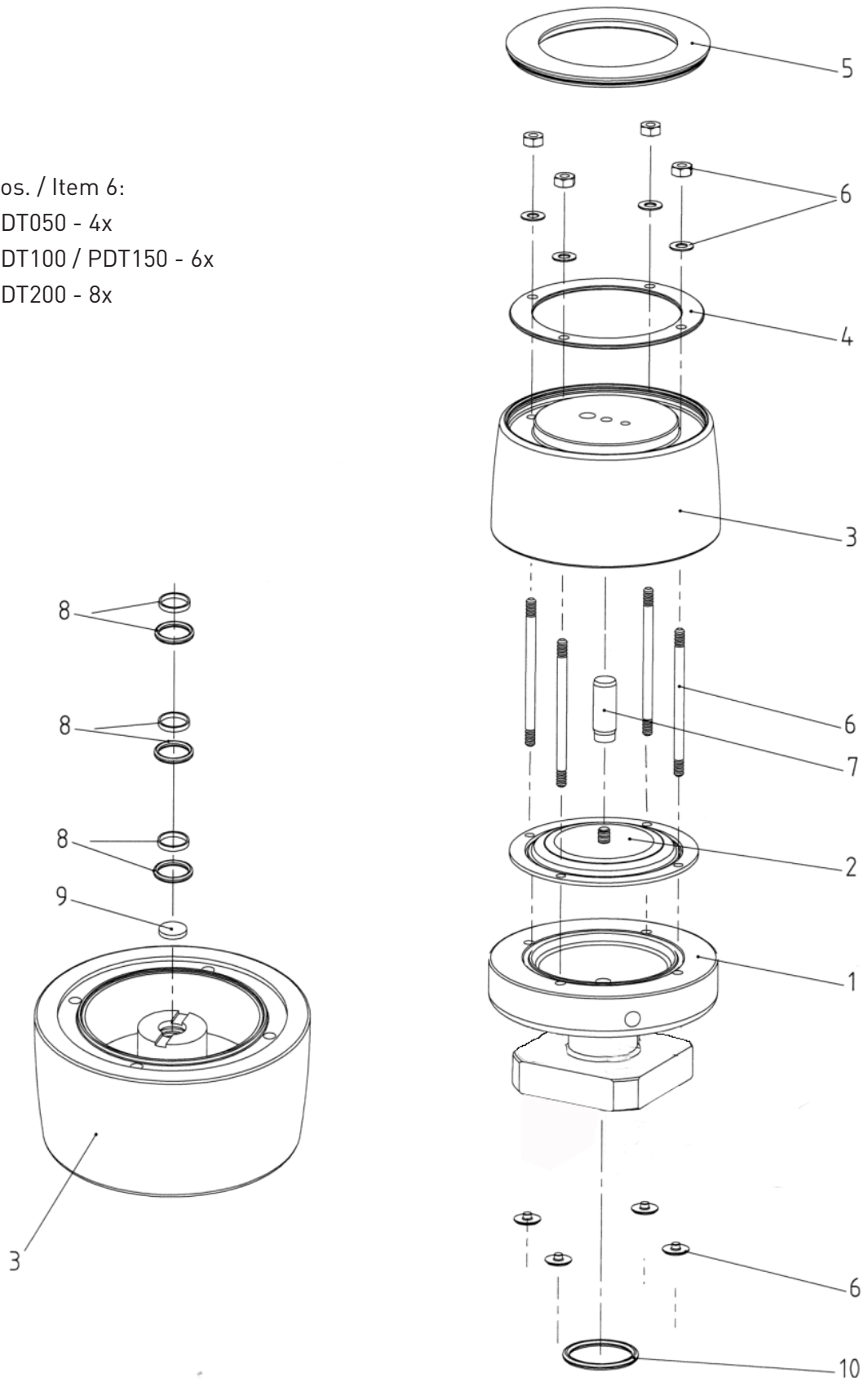

PARTS LIST - ANSI FLANGE CONNECTION

PUMP SIZE				PDT050	PDT100	PDT150	PDT200
ITEM	PC.	DESCRIPTION	MATERIAL				
1	1	DAMPENER HOUSING MATERIAL J	CONDUCTIVE PE	7 15 280 56	7 25 280 56	7 40 280 56	7 50 280 56
		DAMPENER HOUSING MATERIAL U	CONDUCTIVE PTFE	7 15 280 68	7 25 280 68	7 40 280 68	7 50 280 68
2	1	DIAPHRAGM E	EPDM	1 10 031 72	1 15 031 72	1 25 031 72	1 40 031 72
		DIAPHRAGM T	PTFE	1 10 031 67	1 15 031 67	1 25 031 67	1 40 031 67
		DIAPHRAGM N	NBR	1 10 031 70	1 15 031 70	1 25 031 70	1 40 031 70
3	1	MATERIALS OF AIR SIDE J	CONDUCTIVE PE	7 15 081 55	7 25 081 55	7 40 081 55	7 50 081 55
4	1	TENSION DISC	1.4301	7 10 008 22	7 15 008 22	7 25 008 22	7 40 008 22
5	1	COVER	CONDUCTIVE PE	7 10 009 55	7 15 009 55	7 25 009 55	7 40 009 55
6	*	HOUSING BOLT, CPL.	1.4301	7 15 083 22	7 25 083 22	7 40 083 22	7 50 083 22
7	1	ACTUATOR SHAFT	1.4301	1 10 482 22	1 15 482 22	1 25 482 22	1 40 482 22
8	3	SHAFT PISTON RING, CPL.	PTFE	1 08 041 64	1 15 041 64	1 25 041 64	1 40 041 64
9	1	MUFFLER	PE	1 08 644 51	1 15 644 51	1 25 644 51	1 40 644 51
10	1	FLANGE O-RING, DIAPHRAGM E	EPDM	9 23 588 72	9 40 613 72	9 62 634 72	9 73 635 72
		FLANGE O-RING, DIAPHRAGM T	FEB	9 23 588 59	9 40 613 59	9 62 634 59	9 73 635 59
		FLANGE O-RING, DIAPHRAGM N	NBR	9 23 588 71	9 40 613 71	9 62 634 71	9 73 635 71
*PDT050: 4 PIECES, PDT100 AND PDT150: 6 PIECES, PDT200 8 PIECES							



PSG

22069 Van Buren Street

Grand Terrace, CA 92313-5651 USA

P: +1 (440) 354-1700 F: +1 (440) 354-9466

all-flo.com

All-Flo is committed to the pursuit of designing and manufacturing the highest quality product available to industry. Since the beginning in 1986, All-Flo engineers have used their extensive knowledge of today's engineered materials, advanced air system logic and manufacturing techniques to develop the superior group of lube-free, air-operated diaphragm pumps found in this catalog. Every pump is performance engineered and quality built to provide trouble-free service under the toughest conditions.



Where Innovation Flows