

1-1/2" Bronze Centrifugal Pumps

- **Bronze Construction**
- **Viton Mechanical Seal and O-Ring**
- **Maximum Working Pressure 75 PSI**
- **Maximum Temperature 180° F**
- **Maximum Flow 130 GPM**
- **Maximum Head 62 Ft.**
- **Self-Cleaning, 1/8" Diameter Solids Handling Stainless Steel Impeller**
- **1/2 to 2 HP Totally Enclosed Fan Cooled (TEFC) Single Phase Motor**

Model 388G-97

AMT Bronze Centrifugal pumps are designed for use with most gravity fed service applications requiring chemical processing and dirty water transfer. All models are fitted with a self-cleaning stainless steel impeller for maximum 1/8" diameter solids handling. Pumps are designed to handle liquids with solids content or dissolved solids and debris. Units feature pull-from-rear design for easy servicing without removing piping. **Pumps are not self-priming and require flooded suction.**

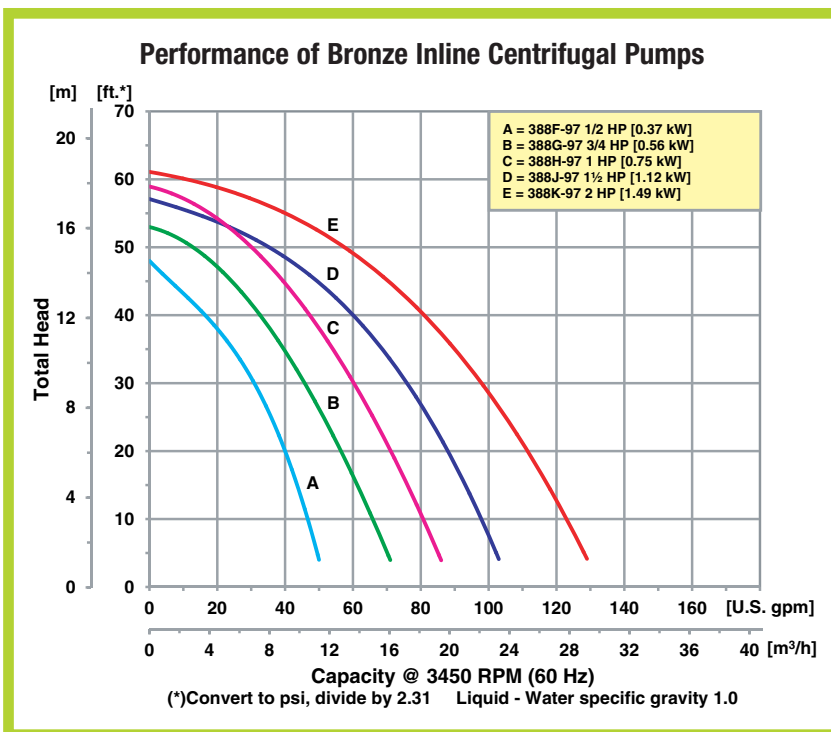

Pump Dimensional & Specification Data

Model	Curve	HP	PH	ENC	Voltage @ 60 Hz	Full Load Amps	SUC*	DIS*	L**	W**	H	Ship Wt. (Lbs.)
388F-97	A	1/2	1	TEFC	115/230	8/4	1½	1½	13.0 [33.0]	8.9 [22.6]	8.7 [22.0]	41
388G-97	B	3/4	1	TEFC	115/230	10/5	1½	1½	13.5 [34.3]	8.9 [22.6]	8.7 [22.0]	47
388H-97	C	1	1	TEFC	115/230	13/7	1½	1½	13.7 [34.8]	8.9 [22.6]	8.7 [22.0]	47
388J-97	D	1½	1	TEFC	115/230	16/8	1½	1½	14.2 [36.0]	8.9 [22.6]	8.7 [22.0]	51
388K-97	E	2	1	TEFC	115/230	17/9	1½	1½	15.0 [38.1]	8.9 [22.6]	8.7 [22.0]	53

(*) Standard NPT (Female) pipe thread.

(**) This dimension may vary due to motor manufacturer's specifications.

NOTE: Dimensions are in inches (centimeters) and have a tolerance of $\pm 1/4$ ".

NOTE: Electric supply for **ALL** motors must be within $\pm 10\%$ of nameplate voltage rating (e.g. 230V $\pm 10\%$ = 207 to 253).

Maximum Solids Handling Capacity: 1/8" Diameter

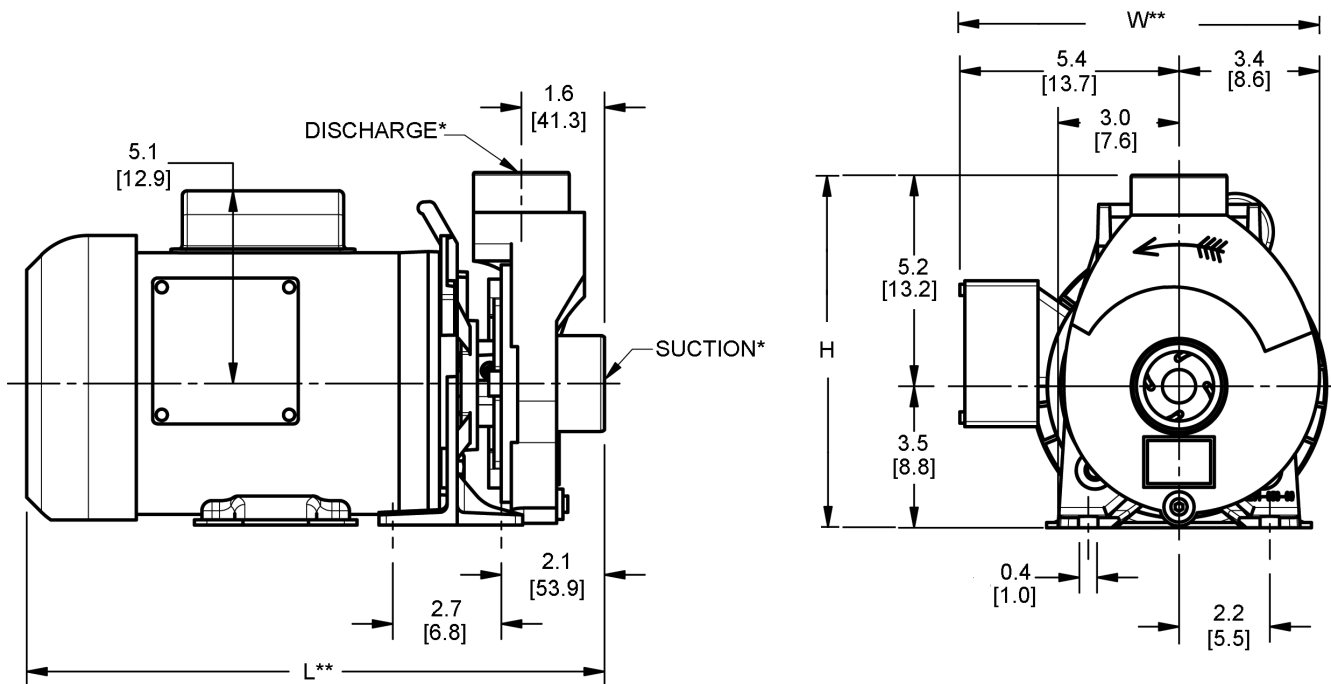

Standard Features

- Bronze Construction
- Viton Mechanical Seal and O-Ring
- 1-1/2" x 1-1/2" NPT Thread
- Maximum Working Pressure 75 PSI
- Maximum Temperature 180° F
- Maximum Head 62 Ft.
- Self-cleaning Stainless Steel Impeller
- 1/2 to 2 HP Totally Enclosed Fan Cooled (TEFC) Single Phase Motors
- Pull-from-Rear Design for Easy Servicing Without Removing Piping
- Maximum 1/8" Diameter Solids Handling

Hazardous Duty/Explosion Proof motors available from stock ranging from 1 to 10 HP; CALL FOR QUOTATION & LEAD TIME!