

Submersible Drainage/ Sump Utility Pump



Model 5792-95

AMT Submersible Sump pumps are designed for many applications including sump pits, drainage pits, overflow tanks, basements, dewatering, excavation, grain elevators, construction drainage, cooling towers and other applications requiring clear water removal. AMT Submersible pumps include suction screen and automatic float switch (except stainless steel model 5780-98).

- **Stainless Steel, Cast Iron and Plastic Construction**
- **Built-in Thermal Protection**
- **Triplex Seal System; Double Mechanical Seals Plus Shaft Seal**
- **Automatic Mercury Free Float Switch Included (Except Stainless Steel Model 5780-98)**
- **U.L./CSA Listed**
- **1/2 HP, 115 VAC UL/SJT Cord with 3 Prong Plug**
- **1-1/2" to 2" NPT Port Sizes**
- **Clog Resistant Impellers**
 - **Solids Handling and Dirty Water Design**
 - **Oil Filled, Quiet Run Motor Design**

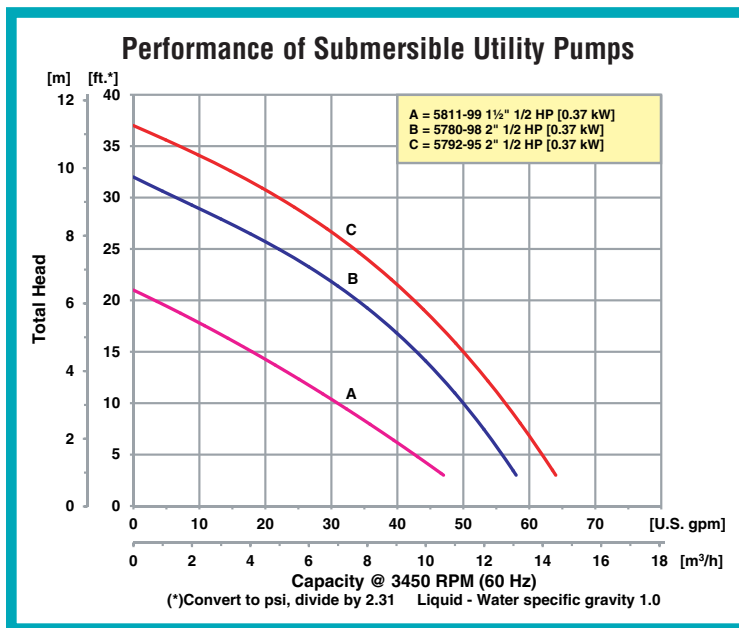

400 Spring Street • Royersford, PA 19468 USA

www.amtpump.com • 888-amt-pump (268-7867)

For use with nonflammable liquids compatible with pump component materials. Viton® is registered trademarks of E. I. DuPont.

Pump Dimensional & Specification Data

Model	Curve	HP	DIS*	Construction Materials	Type	Voltage @ 60 Hz	Full Load Amps	Cord Length (Ft.)	Ship Wt. (Lbs.)
5811-99	A	1/2	1.5"	Plastic	Vortex	115	5	12	15
5780-98	B	1/2	2"	Stainless Steel	Drainage	115	5	20	26
5792-95	C	1/2	2"	Cast Iron	Drainage	115	7	20	42

(*) Standard NPT (Female) pipe thread

NOTE: Electric Supply for ALL motors must be within $\pm 10\%$ of nameplate voltage (Ex: 230V = 203 to 253)

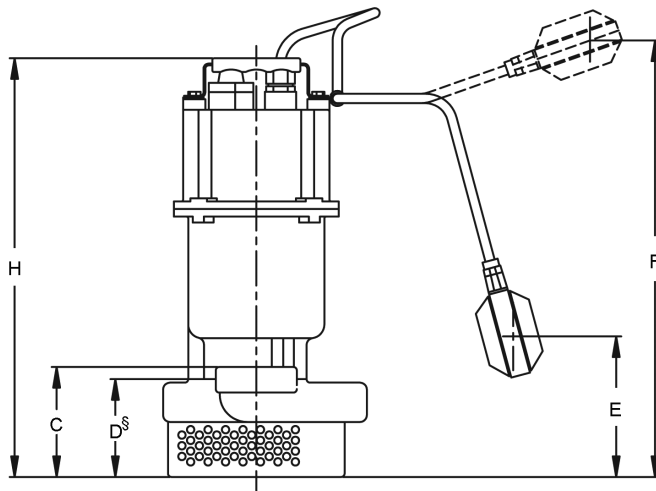
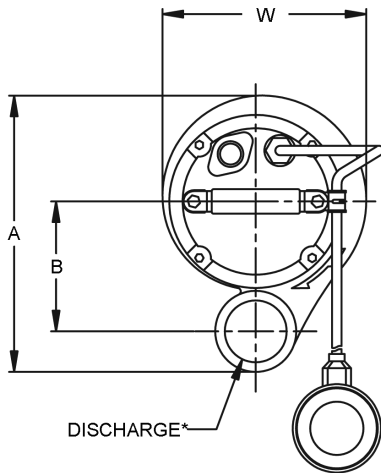

Model	Screen	A	B	C	D ^S	E	F	W	H
5811-99	1/2 x 1-1/2	9.4 [23.8]	5.0 [12.7]	4.6 [11.6]	4.1 [10.4]	3.0 [7.6]	13.0 [33.0]	6.2 [15.7]	12.6 [32.0]
5780-98	3/16 Dia.	9.0 [22.8]	4.7 [11.9]	3.9 [9.9]	3.1 [7.9]	N/A	N/A	6.3 [16.0]	16.3 [41.4]
5792-95	1/4 Dia.	10.0 [25.4]	4.7 [11.9]	3.9 [9.9]	3.3 [8.4]	3.5 [8.9]	17.7 [45.0]	7.4 [18.8]	16.1 [41.4]

NOTE: Dimensions are in inches (centimeters) and have a tolerance of $\pm 1/8$ ".

(S) Minimum Liquid Height

Standard Features

- UL/CSA Listed
- Automatic Float Switch (except Stainless Steel Model 5780-98)
- Double Mechanical Seal Construction
- Model 5811-99: Plastic Submersible Includes Hose Adapter
- Maximum Temperature 104° F
- Suction Screen
- 115 VAC UL/SJTW Cord with 3 Prong Plug
- Carry Handle Built-In
- Thermally Protected
- Oil Filled, Quiet Run Motor Design
- QSP – Quick Ship Pumps