

MTH Pumps DC Series

Centrifugal Pumps

Design Features

- 100% Solid Stainless Steel Construction
- Capacities to 25 GPM
- Heads to 92 Feet (40 PSI)
- Temperatures from -20° to 250°F
- End Suction and Top, Bottom, or Side Discharge
- 12VDC 1HP TENV Motor

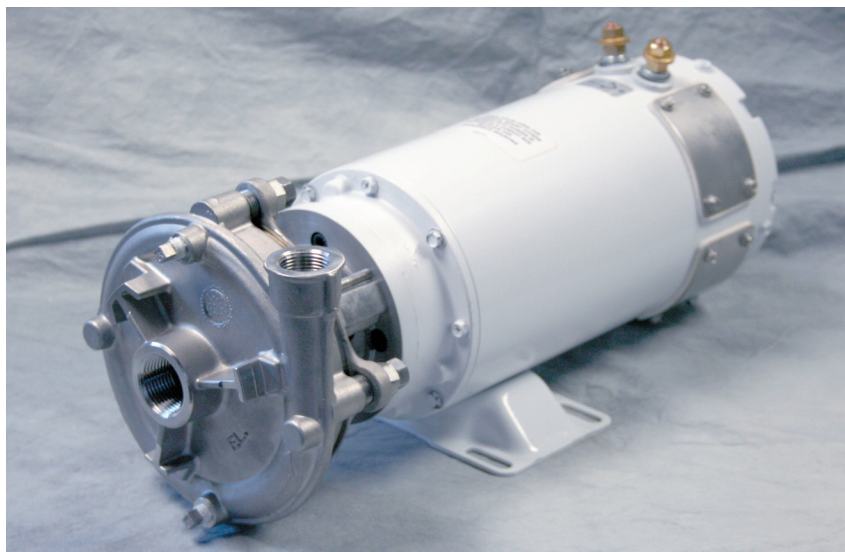
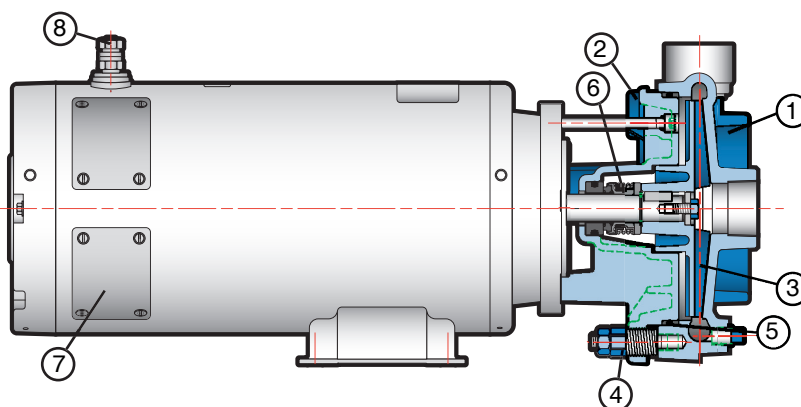

Diagram & Specs

- (1) Stainless Steel Casing
- (2) Stainless Steel Motor Bracket
- (3) Cast Stainless Steel Impeller
- (4) Adjustable Impeller to Casing Clearance
- (5) "O" Ring Style Elastomer
- (6) Long Lasting Dry Run Mechanical Seal
- (7) Totally Enclosed DC Motor
- (8) Easy Access Brass Terminals



Construction Materials

PART	STANDARD CONSTRUCTION	OPTIONAL MATERIALS
Motor Bracket and Casing	Stainless Steel	---
Impeller	Stainless Steel	---
Motor Shaft	Stainless Steel	---
Elastomers	Buna	EPR/Viton
Seals	Carbon/EPR	Silicon Carbide
Seats	Ceramic/EPR	Silicon Carbide

Optional Features

Seal Flushing Lines can be added for extended life of the Mechanical Seals, especially when pumping fluids that contain solids and debris.

For ease of installation, the pump discharge can be rotated in 90° increments by rotating the casing during the assembly process.

Limitations

Casing Pressure	200 PSI
Seal Pressure* (Max)	145 PSI
Suction Pressure (Min.)	26" Hg Vac.
Speed (Max.)	3600 RPM
Temperature	
Standard Construction	-20° F
Ceramic Seal Seat - Water	+230° F
Silicon Carbide	+250° F
Horsepower	
12 VDC	1 HP

* Consult factory for pressures over 145 psi



MTH PUMPS

401 West Main Street • Plano, IL 60545-1436
 Phone: 630-552-4115 • Fax: 630-552-3688
 Email: ISM@MTHPUMPS.COM
 http://WWW.MTHPUMPS.COM

DC Series

Performance Curves

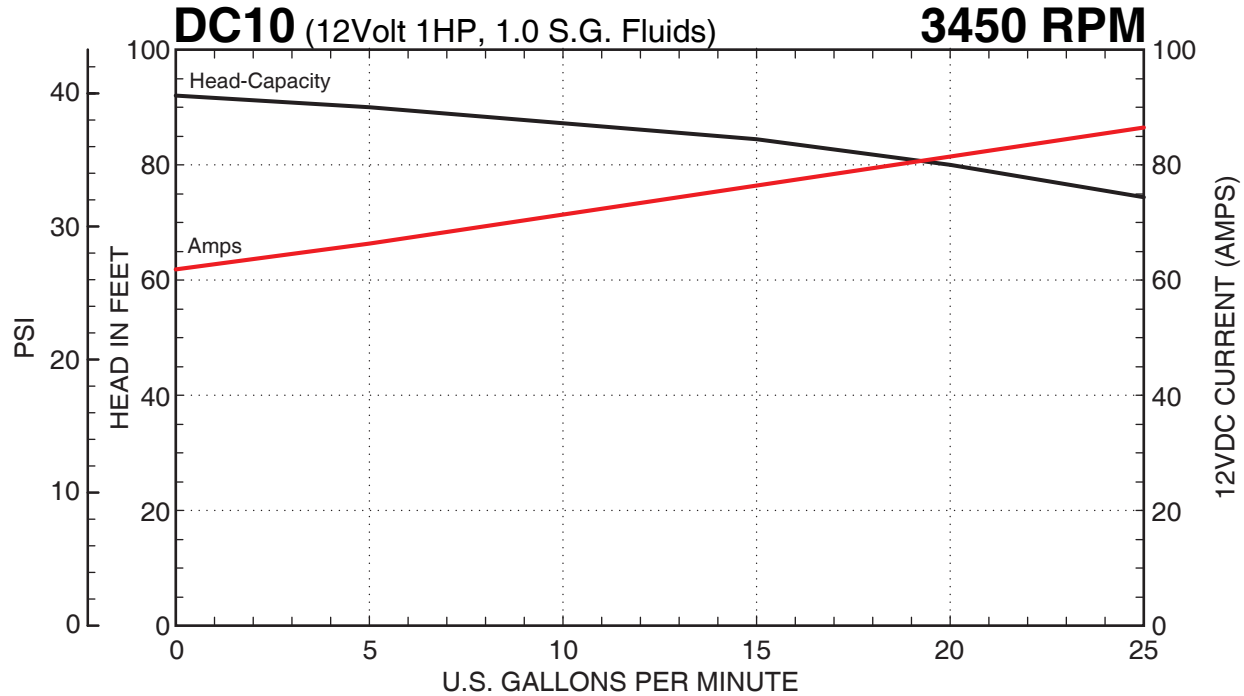

Dimensions

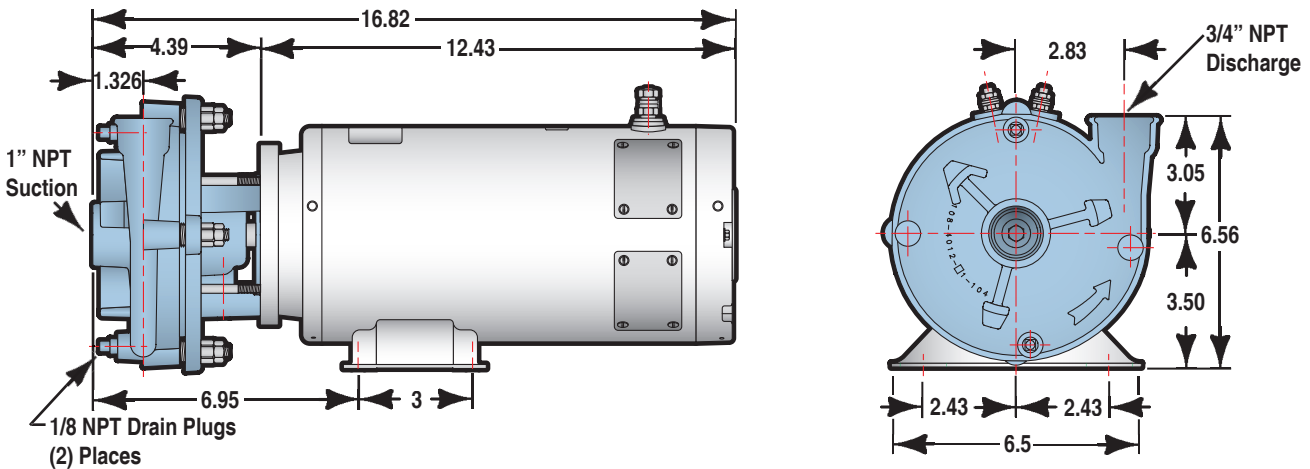

Design Features

Impeller Design

DC Series semi-open impellers allow the pump to pass small solids and fibrous material while close running tolerances maintain high efficiency and performance. Impellers are pre-trimmed to be non-overloading to the pump and motor size indicated.

Axial Balance System

The DC Series pumps utilize a thrust balancing system which combines the advantages of both static and dynamic balancing techniques to reduce axial thrust and provide longer bearing life.

Mechanical Seal Box

The large seal chamber provides a wide fluid passage area for maximum cooling of the seal faces and allows debris and gases to be flushed away.

Adjustable Casing

DC Series pump casings are axially adjustable allowing the use of custom impellers for OEM applications and to allow restoration of performance by closing up the internal clearances that develop over the course of a unit's extended service life.



MTH PUMPS

401 West Main Street • Plano, IL 60545-1436
 Phone: 630-552-4115 • Fax: 630-552-3688
 Email: ISM@MTHPUMPS.COM
<http://WWW.MTHPUMPS.COM>