

**Contents**

**Model DVFU**

50DVFU61.5	80DVFU61.5	100DVFU63.7	150DVBFU611
50DVFU62.2	80DVBFU62.2	100DVFU65.5	150DVBFU615
	80DVCFU62.2	100DVFU67.5	150DVBFU618
	80DVBFU63.7	100DVBFU611	150DVCFU618
	80DVCFU63.7	100DVCFU611	150DVBFU622
	80DVFU65.5	100DVDFU611	150DVCFU622
	80DVFU67.5	100DVCFU615	
	80DVBFU611	100DVDFU615	
	80DVCFU611	100DVDFU618	
	80DVCFU615	100DVDFU622	
	80DVCFU618		
	80DVCFU622		

Section	Page
Specifications	2-217
Selection Chart	2-217
Performance Curves	2-222
Outline Drawings	2-232
Sectional View	2-245
QDC Information	2-278
Technical Information	2-289.1
material specification	
impeller description	
motor protection	
cable entry	
paint specifications	
mechanical seal	
general	
Motor Data	2-315.1
motor electrical specifications	
cable data	
wiring diagrams	
motor electrical data	

**Model Designation**

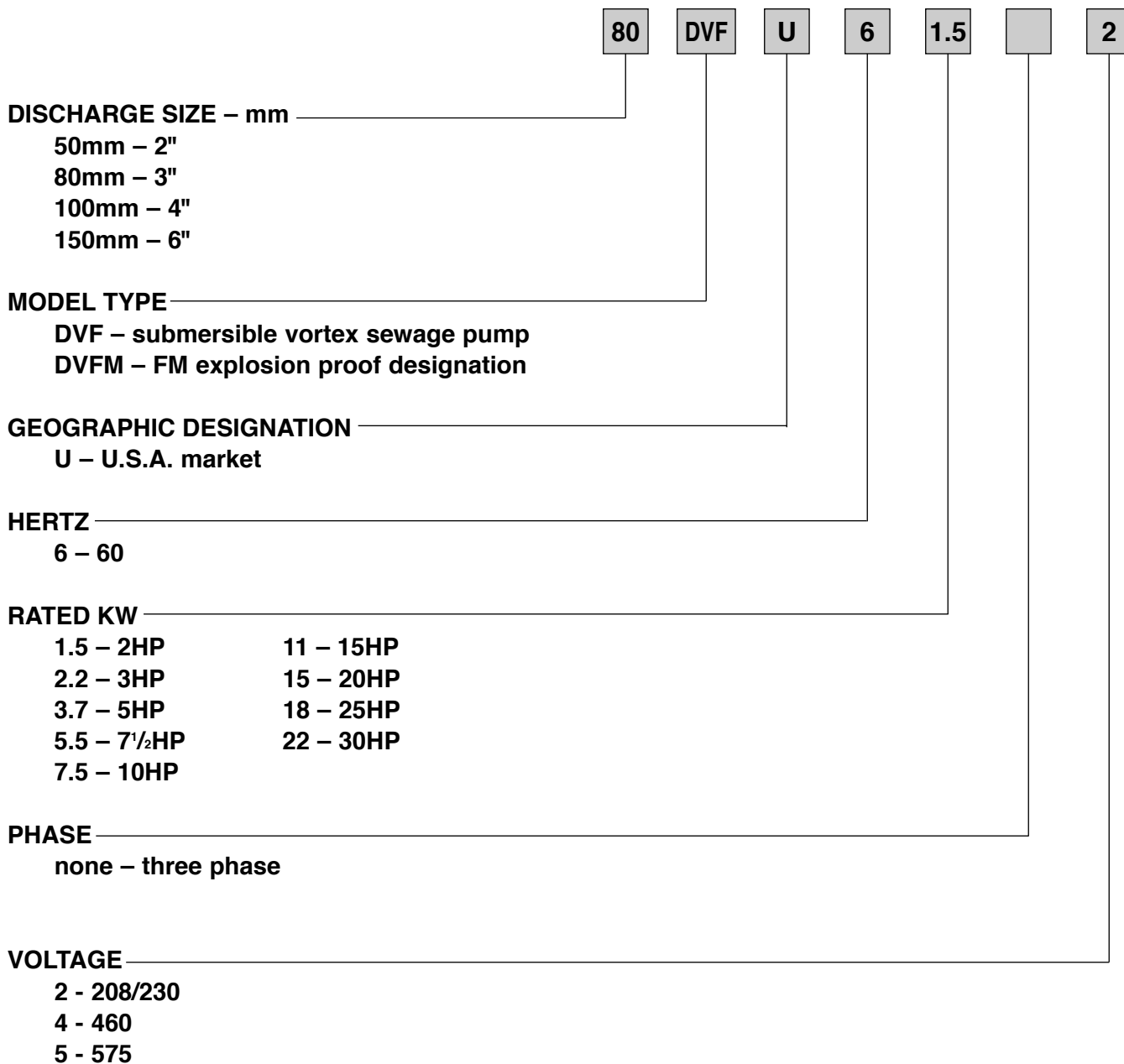

**Specifications**

	Standard	Optional
Size	2, 3, 4, 6 inch	
Range of HP Range of Performance	2 to 30 HP Capacity 16 to 1200 GPM Head 13 to 121 feet	
<b>Limitation</b> Maximum Water Temperature	104°F (40°C)	
<b>Synchronous Speed</b>	1800 RPM	
<b>Materials</b> Casing Impeller Shaft  Motor Frame Fastener	Cast Iron Cast Iron 403 Stainless Steel for 2 to 5HP 420 Stainless Steel for 7½ to 30HP Cast Iron 304 Stainless Steel	
<b>Mechanical Seal</b> Material   Upper Side Material   Lower Side Impeller Type Bearing Motor Three Phase Motor Protection	Double Mechanical Seal Carbon/Ceramic Silicon Carbide/Silicon Carbide Semi-open Recessed Vortex Prelubricated Ball Bearing Insulation Class H 208/230V, 460V Built-in Thermal Detector   Klixons Built-in Leakage Detector	FM Explosion Proof, Class 1, Division 1, Group C, D
Submersible cable	33 ft. (2 to 5 HP) 50 ft. (7½ to 30 HP)	____ ft. (customer specified)
Accessories		QDC System

Selection chart

Three Phase

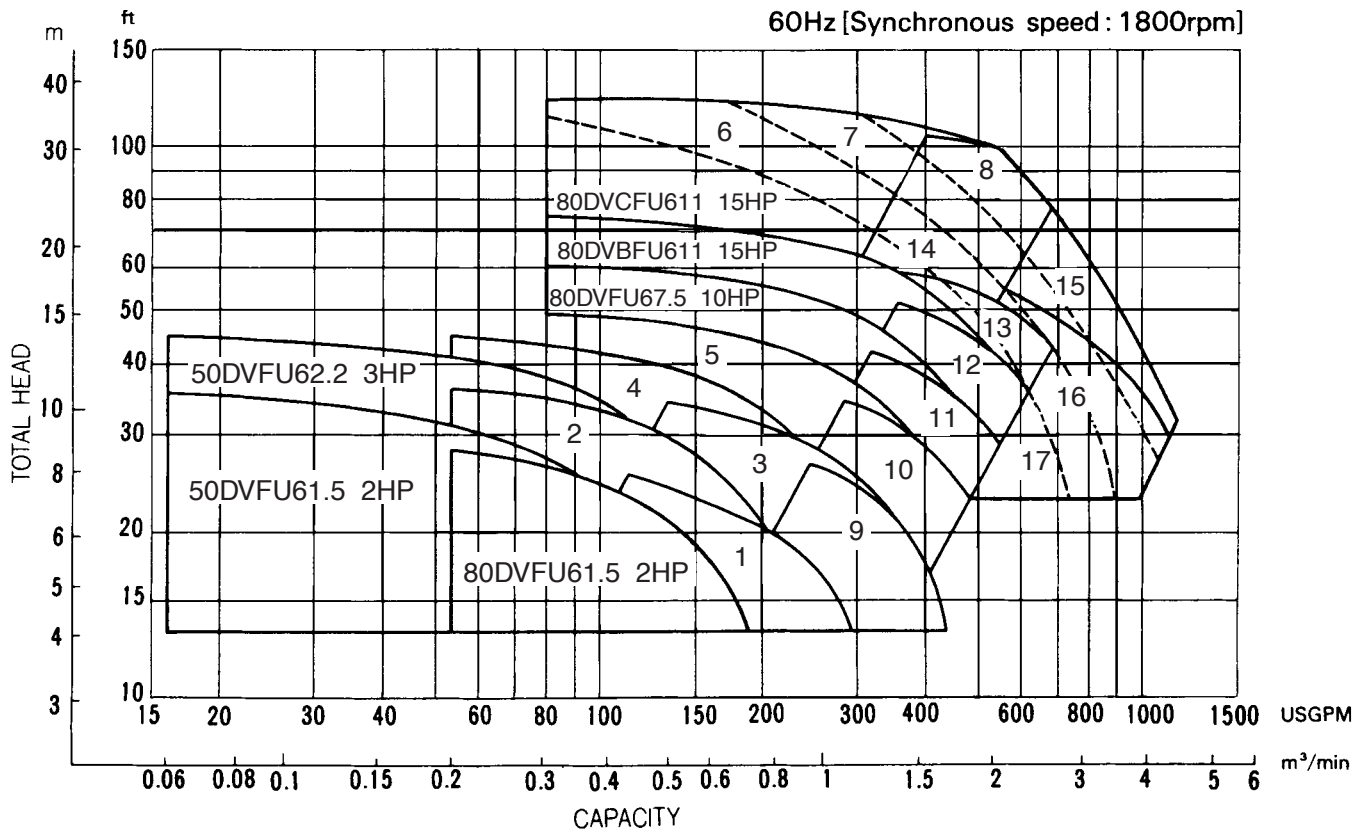

- |                   |                     |
|-------------------|---------------------|
| 1 80DVBFU62.2 3HP | 10 100DVFU65.5 7HP  |
| 2 80DVCFU62.2 3HP | 11 100DVFU67.5 10HP |
| 3 80DVBFU63.7 5HP | 12 100DVBFU611 15HP |
| 4 80DVCFU63.7 5HP | 13 100DVCFU611      |
| 5 80DVFU65.5 7HP  | 14 100DVCFU615      |
| 6 80DVFU615 20HP  | 15 150DVCFU622      |
| 7 80DVFU618 25HP  | 16 150DVBFU622      |
| 8 80DVFU622 30HP  | 17 150DVBFU622 15HP |
| 9 100DVFU63.7 5HP |                     |

**Specifications**

**A. General:**

Provide submersible recessed impeller, vortex type sewage pumps suitable for continuous duty operation underwater without loss of watertight integrity to a depth of 65 feet. Pump system design shall include a guide rail system be such that the pump will be automatically connected to the discharge piping when lowered into place on the discharge connection. The pump shall be easily removable for inspection or service, requiring no bolts, nuts, or other fasteners to be disconnected, or the need for personnel to enter the wet well. The motor and pump shall be designed, manufactured, and assembled by the same manufacturer.

**B. Manufacturer:**

EBARA International Corporation

**C. Pump Characteristics:**

Pumps shall conform to the following requirements:

Number of units	
Design flow (gpm)	
Design TDH (ft)	
Minimum shut off head (ft)	
RPM	1800
Maximum HP	
Minimum efficiency at design (%)	
Minimum power factor at design (%)	
Voltage/HZ	208/230V, 460V / 60
Phase	3

**D. Pump Construction:**

All major parts of the pumping unit(s) including casing, impeller, motor frame and discharge elbow shall be manufactured from gray cast iron, ASTM A-48 Class 30. Castings shall have smooth surfaces devoid of blow holes or other casting irregularities. Casing design shall be centerline discharge with a large radius on the cut water to prevent clogging. Units shall be furnished with a discharge elbow and 125 lb. flat face ANSI flange. All exposed bolts and nuts shall be 304 stainless steel. All mating surfaces of major components shall be machined and fitted with NBR O-rings where watertight sealing is required. Machining and fitting shall be such that sealing is accomplished by automatic compression of O-rings in two planes and O-ring contact is made on four surfaces without the requirement of specific torque limits. Internal and external surfaces are prepared to SPPC-VISI-SP-3-63 then coated with a zinc-chromate primer. The external surfaces are then coated with an H.B. Tnemecol 46-465 Coal Tar paint.

Impeller design shall be a semi-open recessed, vortex, multi-vane design, direct connected to the motor shaft with a slip fit, key driven, and secured with an impeller nut. The inlet edge of the impeller vanes shall be angled toward the impeller periphery so as to facilitate the release of objects that might otherwise clog the pump. The design shall also include back pump out vanes to reduce the pressure and entry of foreign materials into the mechanical seal area. In addition, a lip seal shall be located behind the impeller hub to further reduce the entry of foreign materials into the seal area on 7½ HP and above.

**1. Mechanical Seals:**

- a. For units 2 to 5 HP, double mechanical seals operating in an oil bath shall be provided on all units. The oil filled seal chamber shall be designed to prevent over-filling and include an anti-vortexing vane to insure proper lubrication of both seal faces. Lower face materials shall be silicon carbide, upper faces carbon vs. ceramic, NBR elastomers, and 304SS hardware. Seal system shall not rely on pumping medium for lubrication.
- b. Units 7½ to 30 HP shall be designed to include a double mechanical seal in a tandem arrangement. Each seal shall be positively driven and act independently with its own spring system. The upper seal operates in an oil bath, while the lower seal is lubricated by the oil from between the shaft and the seal faces, and in contact with the pumpage on the outside. Lower face materials shall be silicon carbide, upper faces carbon vs. ceramic, NBR elastomers, and 304SS hardware. Seal system shall not rely on pumping medium for lubrication.



---

**Specifications**

---

**E. Motor Construction:**

The pump motor shall be an air filled induction type with a squirrel cage rotor, shell type design, built to NEMA MG-1, Design B specifications. Stator windings shall be copper, insulated with moisture resistant Class H insulation, rated for 311°F. The stator shall be dipped and baked three times in Class H varnish and heat shrunk fitted into the stator housing. Rotor bars and short circuit rings shall be manufactured of cast aluminum. Motor shaft shall be one piece AISI403 for 2 to 5HP, AISI420 for 7½ to 30 HP material, rotating on two permanently lubricated ball bearings designed for a minimum B-10 life of 60,000 hours. Motor service factor shall be 1.15 and capable of up to 20 starts per hour. The motor shall be designed for continuous duty pumping at a maximum sump temperature of 104°F. Voltage and frequency tolerances shall be a maximum 10 / 5% respectively. Motor over temperature protection shall be provided by miniature thermal protectors embedded in the windings. Mechanical seal failure protection shall be provided by a mechanical float switch located in a chamber above the seal. This switch shall be comprised of a magnetic float that actuates a dry reed switch encapsulated within the stem. Should the mechanical seal fail, liquid shall be directed into the float chamber, in which the rising liquid activates the switch opening the normally closed circuit. For units 2 to 10HP the float body and float shall be a polypropylene material with a 316SS stopper. Units 15HP and greater, the float switch components shall be 304SS. The motor shall be non overloading over the entire specified range of operation and be able to operate at full load intermittently while unsubmerged without damage to the unit.

Power cable jacket shall be manufactured of an oil resistant chloroprene rubber material, designed for submerged applications. Cable shall be watertight to a depth of at least 65'. The cable entry system shall comprise of primary, secondary, and tertiary sealing methods. The primary seal shall be achieved by an cylindrical elastomeric grommet compressed between the motor cover and a 304SS washer. Secondary sealing is accomplished with a compressed O-ring made of NBR material. Compression and subsequent sealing shall preclude specific torque requirements. The system shall also include tertiary sealing to prevent leakage into the motor housing due to capillary action through the insulation if the cable is damaged or cut. The cable wires shall be cut, stripped, re-connected with a copper butt end connector, and embedded in epoxy within the cable gland. This provides a dead end for leakage through the cable insulation into the motor junction area.

**F. Guide Rail system:**

Design shall include two (2) 304SS schedule 40 guide rails sized to mount directly to the quick discharge connector, QDC, at the floor of the wetwell and to a guide rail bracket at the top of the wetwell below the hatch opening, (refer to project drawings). Intermediate guide brackets are recommended for rail lengths over 15 feet.

Guide rails are not part of the pump package and shall be supplied by others.

The QDC shall be manufactured of cast iron, A48 Class 30. It shall be designed to adequately support the guide rails, discharge piping, and pumping unit under both static and dynamic loading conditions with support legs that are suitable for anchoring it to the wetwell floor. The face of the inlet QDC flange shall be perpendicular to the floor of the wetwell. The discharge flange of the QDC shall conform to ANSI B16.1 Class 125.

The pump design shall include an integral self-aligning sliding bracket. Sealing of the pumping unit to the QDC shall be accomplished by a single, linear, downward motion of the pump. The entire weight of the pump unit shall be guided to and wedged tightly against the inlet flange of the QDC, making metal to metal contact with the pump discharge forming a seal without the use of bolts, gaskets or O-rings.

A stainless steel lifting chain of adequate length for removing and installing the pump unit is recommended. The chain shall have a round link with a 2-¼" inside diameter every two feet. This link will allow for a sliding pinch bar through the link to pick the chain, more than once if necessary, at multiple intervals during pump removal and installation.



**Specifications**

**A. General:**

Provide FM explosion proof submersible recessed impeller vortex type sewage pumps suitable for continuous duty operation underwater without loss of watertight integrity to a depth of 65 feet. Pump system design shall include a guide rail system be such that the pump will be automatically connected to the discharge piping when lowered into place on the discharge connection. The pump shall be easily removable for inspection or service, requiring no bolts, nuts, or other fasteners to be disconnected, or the need for personnel to enter the wet well. The motor and pump shall be designed, manufactured, and assembled by the same manufacturer.

**B. Manufacturer:**

EBARA International Corporation

**C. Pump Characteristics:**

Pumps shall conform to the following requirements:

Number of units	
Design flow (gpm)	
Design TDH (ft)	
Minimum shut off head (ft)	
RPM	1800
Maximum HP	
Minimum efficiency at design (%)	
Minimum power factor at design (%)	
Voltage/HZ	208/230V, 460V / 60
Phase	3

**D. Pump Construction:**

All major parts of the pumping unit(s) including casing, impeller, motor frame and discharge elbow shall be manufactured from gray cast iron, ASTM A-48 Class 30. Castings shall have smooth surfaces devoid of blow holes or other casting irregularities. Casing design shall be centerline discharge with a large radius on the cut water to prevent clogging. Units shall be furnished with a discharge elbow and 125 lb. flat face ANSI flange. All exposed bolts and nuts shall be 304 stainless steel. All mating surfaces of major components shall be machined and fitted with NBR O-rings where watertight sealing is required. Machining and fitting shall be such that sealing is accomplished by automatic compression of O-rings in two planes and O-ring contact is made on four surfaces without the requirement of specific torque limits. Internal and external surfaces are prepared to SPPC-VISI-SP-3-63 then coated with a zinc-chromate primer. The external surfaces are then coated with an H.B. Tnemecol 46-465 Coal Tar paint.

Impeller design shall be a semi-open, recessed, vortex, multi-vane design, direct connected to the motor shaft with a slip fit, key driven, and secured with an impeller nut. The inlet edge of the impeller vanes shall be angled toward the impeller periphery so as to facilitate the release of objects that might otherwise clog the pump. The design shall also include back pump out vanes to reduce the pressure and entry of foreign materials into the mechanical seal area. In addition, a lip seal shall be located behind the impeller hub to further reduce the entry of foreign materials into the seal area on 7½ HP and above.

**1. Mechanical Seals:**

- a. For units 2 to 5 HP, double mechanical seals operating in an oil bath shall be provided on all units. The oil filled seal chamber shall be designed to prevent over-filling and include an anti-vortexing vane to insure proper lubrication of both seal faces. Lower face materials shall be silicon carbide, upper faces carbon vs. ceramic, NBR elastomers, and 304SS hardware. Seal system shall not rely on pumping medium for lubrication.
- b. Units 7½ to 30 HP shall be designed to include a double mechanical seal in a tandem arrangement. Each seal shall be positively driven and act independently with its own spring system. The upper seal operates in an oil bath, while the lower seal is lubricated by the oil from between the shaft and the seal faces, and in contact with the pumpage on the outside. Lower face materials shall be silicon carbide, upper faces carbon vs. ceramic, NBR elastomers, and 304SS hardware. Seal system shall not rely on pumping medium for lubrication.



**Specifications****E. Motor Construction:**

The pump motor shall be FM Explosion Proof, Class 1, Division 1, Groups C, D. The design shall be an air filled induction type with a squirrel cage rotor, shell type design, built to NEMA MG-1, Design B specifications. Stator windings shall be copper, insulated with moisture resistant Class H insulation, rated for 311°F. The stator shall be dipped and baked three times in Class H varnish and heat shrunk fitted into the stator housing. Rotor bars and short circuit rings shall be manufactured of cast aluminum. Motor shaft shall be one piece AISI403 for 2 to 5HP, AISI420 for 7½ to 30HP material, rotating on two permanently lubricated ball bearings designed for a minimum B-10 life of 60,000 hours. Motor service factor shall be 1.15 and capable of up to 20 starts per hour. The motor shall be designed for continuous duty pumping at a maximum sump temperature of 104°F. Voltage and frequency tolerances shall be a maximum 10 / 5% respectively. Motor over temperature protection shall be provided by miniature thermal protectors embedded in the windings. Mechanical seal failure protection shall be provided by a mechanical float switch located in a chamber above the seal. This switch shall be comprised of a magnetic float that actuates a dry reed switch encapsulated within the stem. Should the mechanical seal fail, liquid shall be directed into the float chamber, in which the rising liquid activates the switch opening the normally closed circuit. For units 2 to 10HP the float body and float shall be a polypropylene material with a 316SS stopper. Units 15HP and greater, the float switch components shall be 304SS. The motor shall be non overloading over the entire specified range of operation and be able to operate at full load intermittently while unsubmerged without damage to the unit.

Power cable jacket shall be manufactured of an oil resistant chloroprene rubber material, designed for submerged applications. Cable shall be watertight to a depth of at least 65'. The cable entry system shall comprise of primary, secondary, and tertiary sealing methods. The primary seal shall be achieved by an cylindrical elastomeric grommet compressed between the motor cover and a 304SS washer. Secondary sealing is accomplished with a compressed O-ring made of NBR material. Compression and subsequent sealing shall preclude specific torque requirements. The system shall also include tertiary sealing to prevent leakage into the motor housing due to capillary action through the insulation if the cable is damaged or cut. The cable wires shall be cut, stripped, re-connected with a copper butt end connector, and embedded in epoxy within the cable gland. This provides a dead end for leakage through the cable insulation into the motor junction area.

**F. Guide Rail system:**

Design shall include two (2) 304SS schedule 40 guide rails sized to mount directly to the quick discharge connector, QDC, at the floor of the wetwell and to a guide rail bracket at the top of the wetwell below the hatch opening, (refer to project drawings). Intermediate guide brackets are recommended for rail lengths over 15 feet. Guide rails are not part of the pump package and shall be supplied by others.

The QDC shall be manufactured of cast iron, A48 Class 30. It shall be designed to adequately support the guide rails, discharge piping, and pumping unit under both static and dynamic loading conditions with support legs that are suitable for anchoring it to the wetwell floor. The face of the inlet QDC flange shall be perpendicular to the floor of the wetwell. The discharge flange of the QDC shall conform to ANSI B16.1 Class 125.

The pump design shall include an integral self-aligning sliding bracket. Sealing of the pumping unit to the QDC shall be accomplished by a single, linear, downward motion of the pump. The entire weight of the pump unit shall be guided to and wedged tightly against the inlet flange of the QDC, making metal to metal contact with the pump discharge forming a seal without the use of bolts, gaskets or O-rings.

A stainless steel lifting chain of adequate length for removing and installing the pump unit is recommended. The chain shall have a round link with a 2-¼" inside diameter every two feet. This link will allow for a sliding pinch bar through the link to pick the chain, more than once if necessary, at multiple intervals during pump removal and installation.





**Performance Curves**

Project: \_\_\_\_\_ GPM: \_\_\_\_\_ TDH: \_\_\_\_\_ EFF: \_\_\_\_\_ HP: \_\_\_\_\_ Chk'd: \_\_\_\_\_ Date: \_\_\_\_\_

**50DVF61.5 (2HP) Synchronous Speed: 1800 RPM**

**2 inch Discharge**

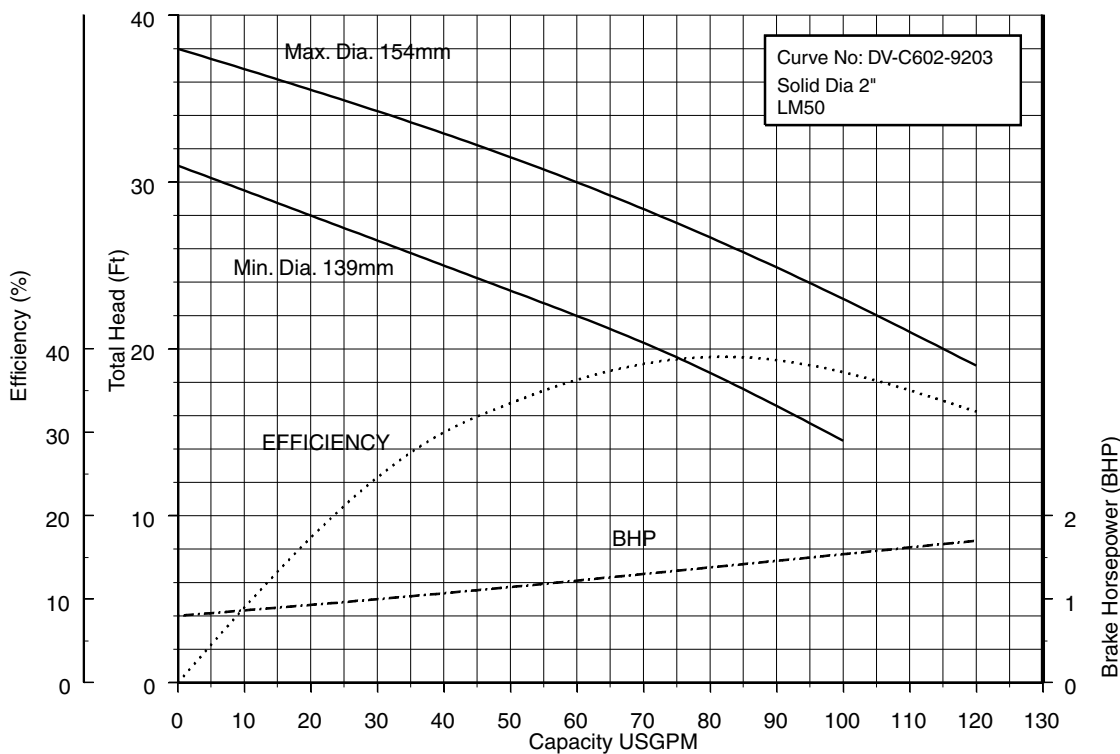

**50DVF62.2 (3HP) Synchronous Speed: 1800 RPM**

**2 inch Discharge**

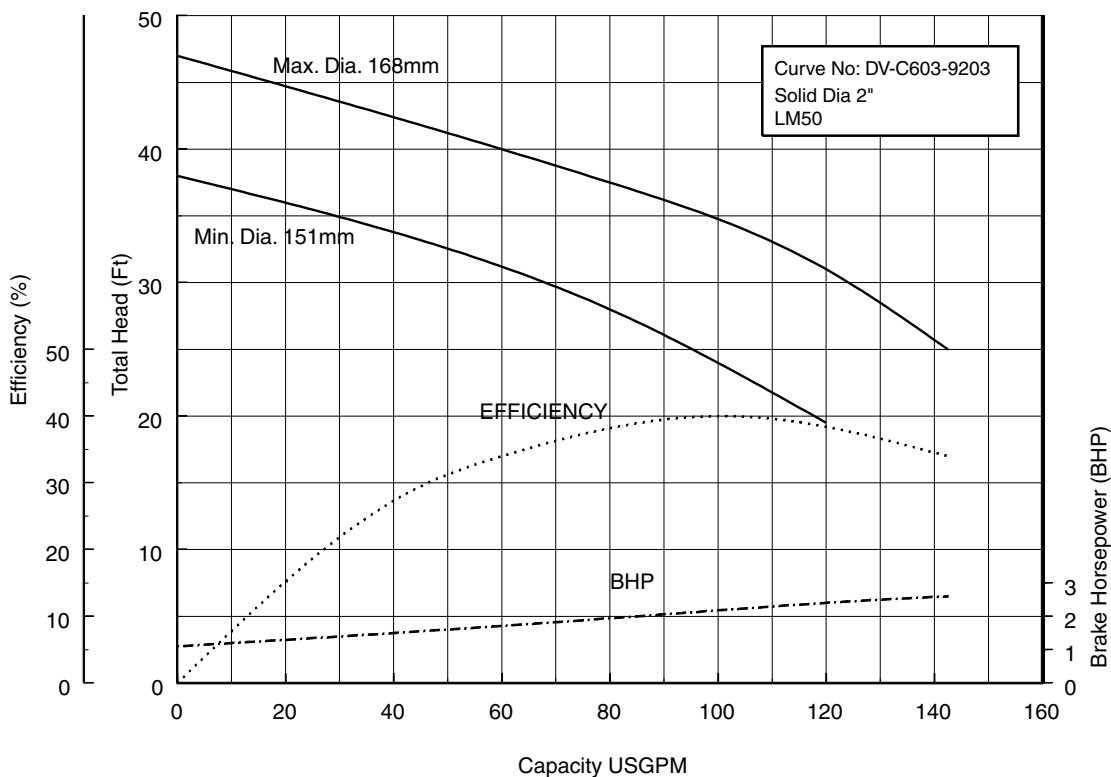

**Performance Curves**

Project: \_\_\_\_\_ GPM: \_\_\_\_\_ TDH: \_\_\_\_\_ EFF: \_\_\_\_\_ HP: \_\_\_\_\_ Chk'd: \_\_\_\_\_ Date: \_\_\_\_\_

**80DVF61.5 (2HP) Synchronous Speed: 1800 RPM**

**2, 3 inch Discharge**

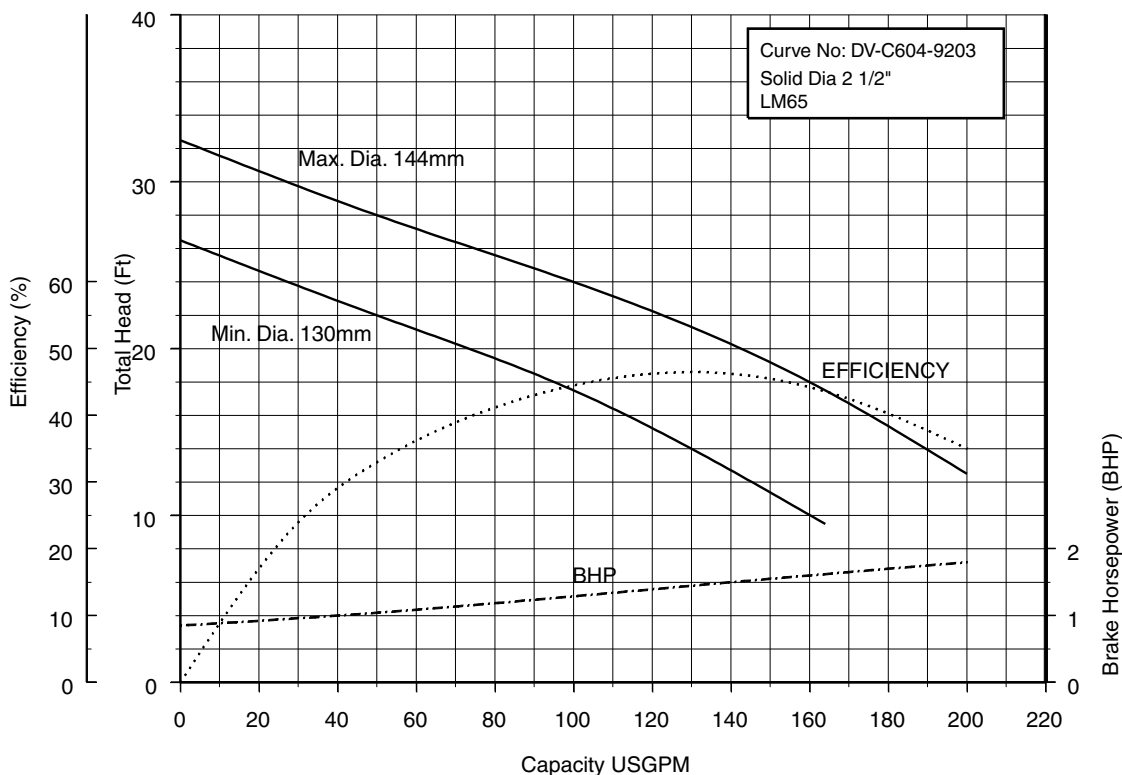

**80DVBF62.2 (3HP) Synchronous Speed: 1800 RPM**

**3, 4 inch Discharge**

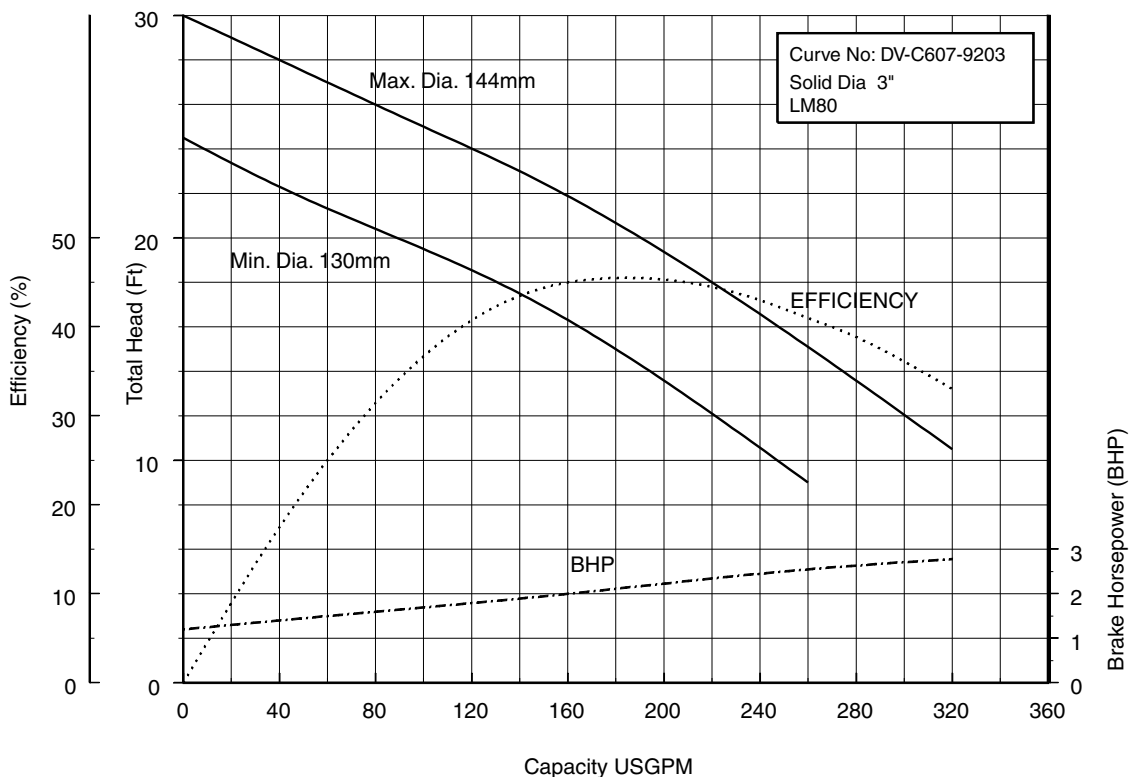

**Performance Curves**

Project: \_\_\_\_\_ GPM: \_\_\_\_\_ TDH: \_\_\_\_\_ EFF: \_\_\_\_\_ HP: \_\_\_\_\_ Chk'd: \_\_\_\_\_ Date: \_\_\_\_\_

**80DVCF62.2 (3HP) Synchronous Speed: 1800 RPM**

**2, 3 inch Discharge**

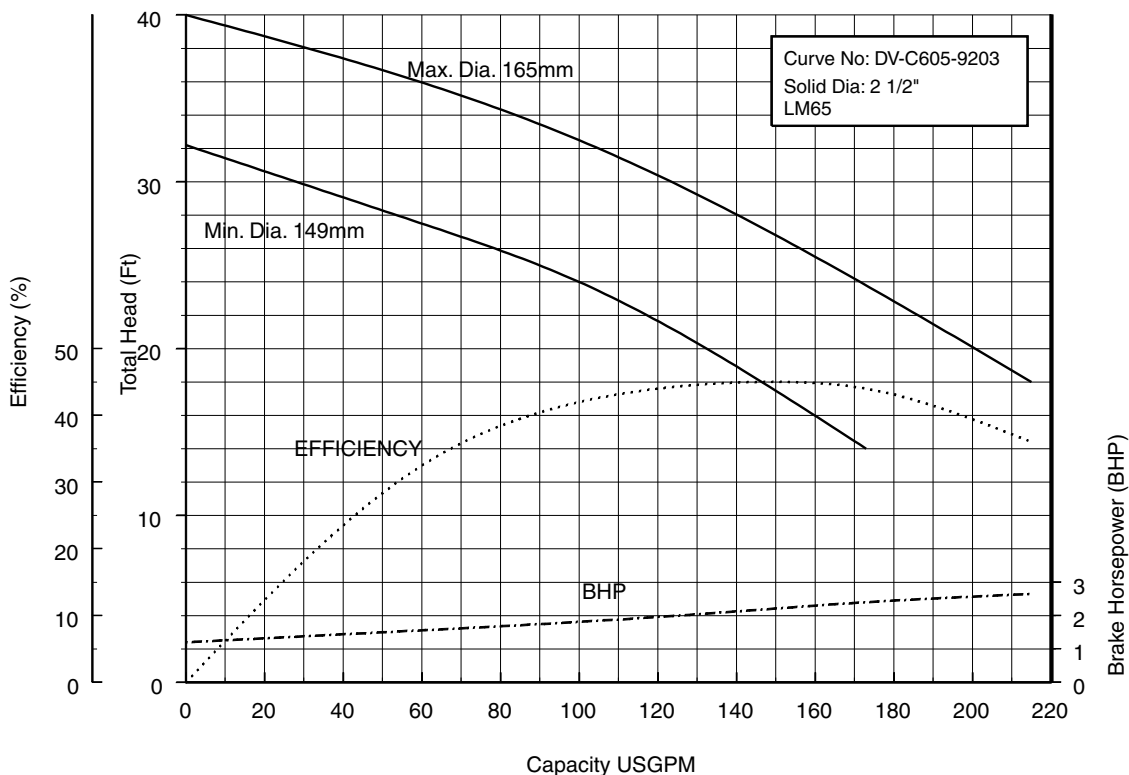

**80DVBF63.7 (5HP) Synchronous Speed: 1800 RPM**

**3, 4 inch Discharge**

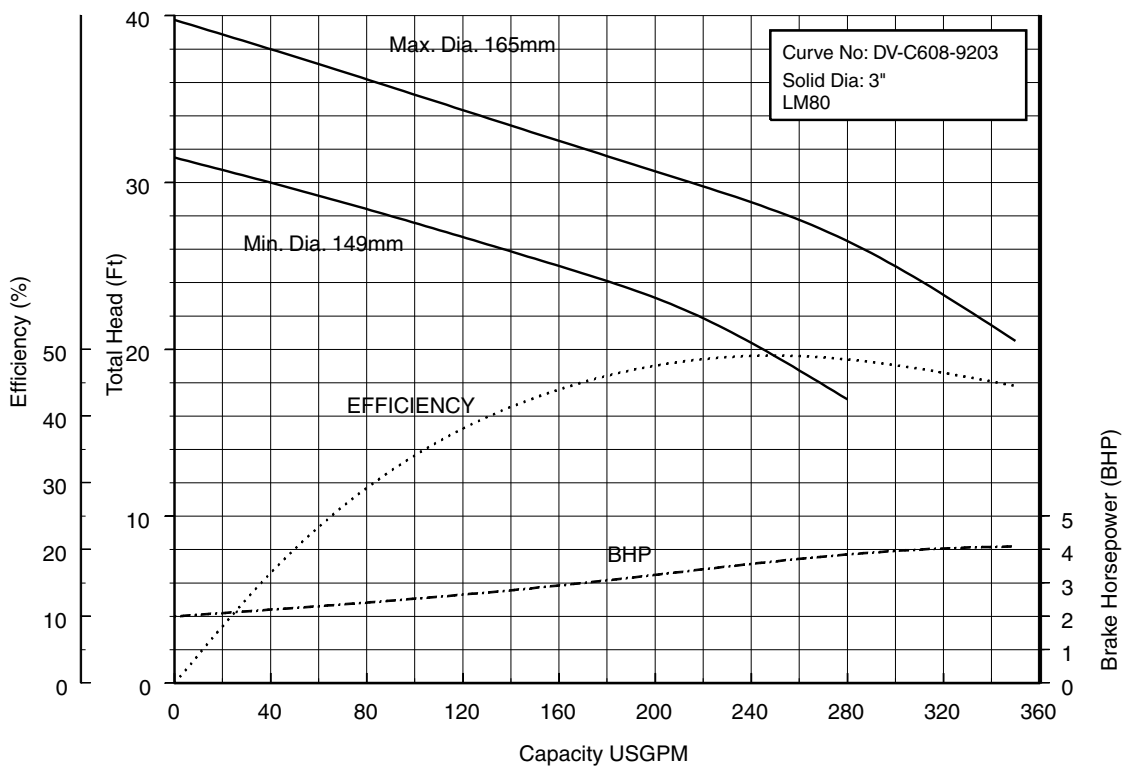

**Performance Curves**

Project: \_\_\_\_\_ GPM: \_\_\_\_\_ TDH: \_\_\_\_\_ EFF: \_\_\_\_\_ HP: \_\_\_\_\_ Chk'd: \_\_\_\_\_ Date: \_\_\_\_\_

**80DVCF63.7 (5HP) Synchronous Speed: 1800 RPM**

**2, 3 inch Discharge**

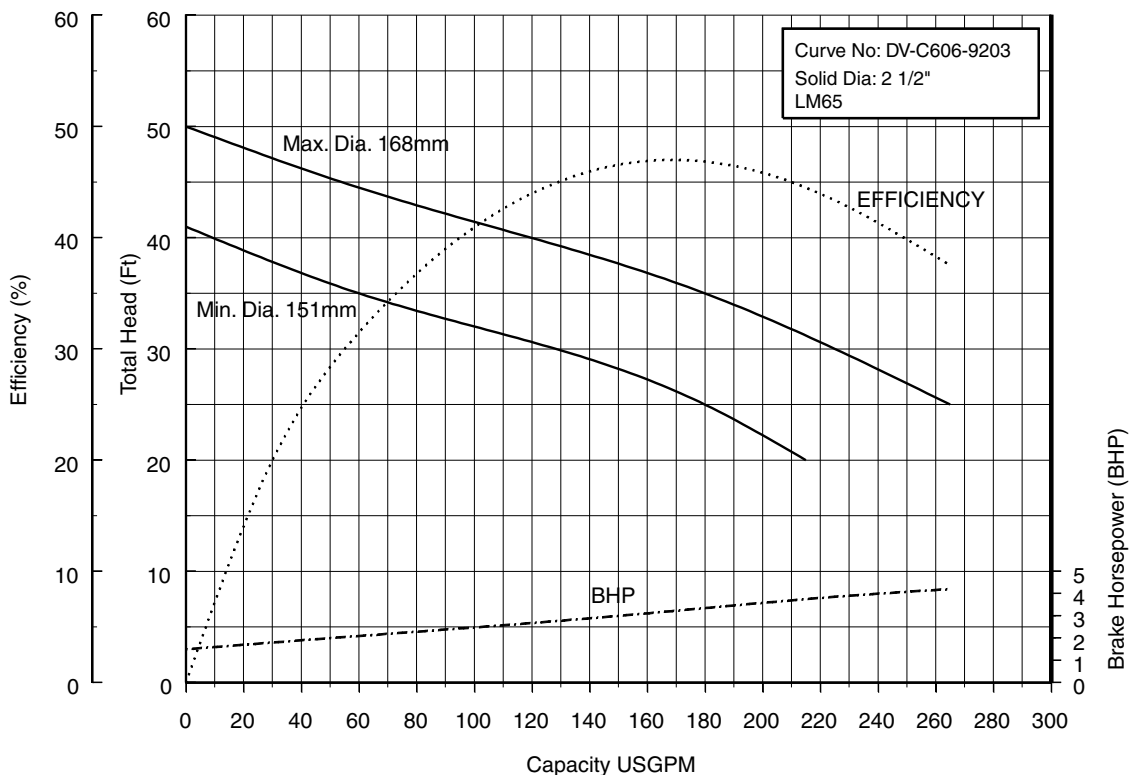

**80DVF65.5 (7½HP) Synchronous Speed: 1800 RPM**

**3, 4 inch Discharge**

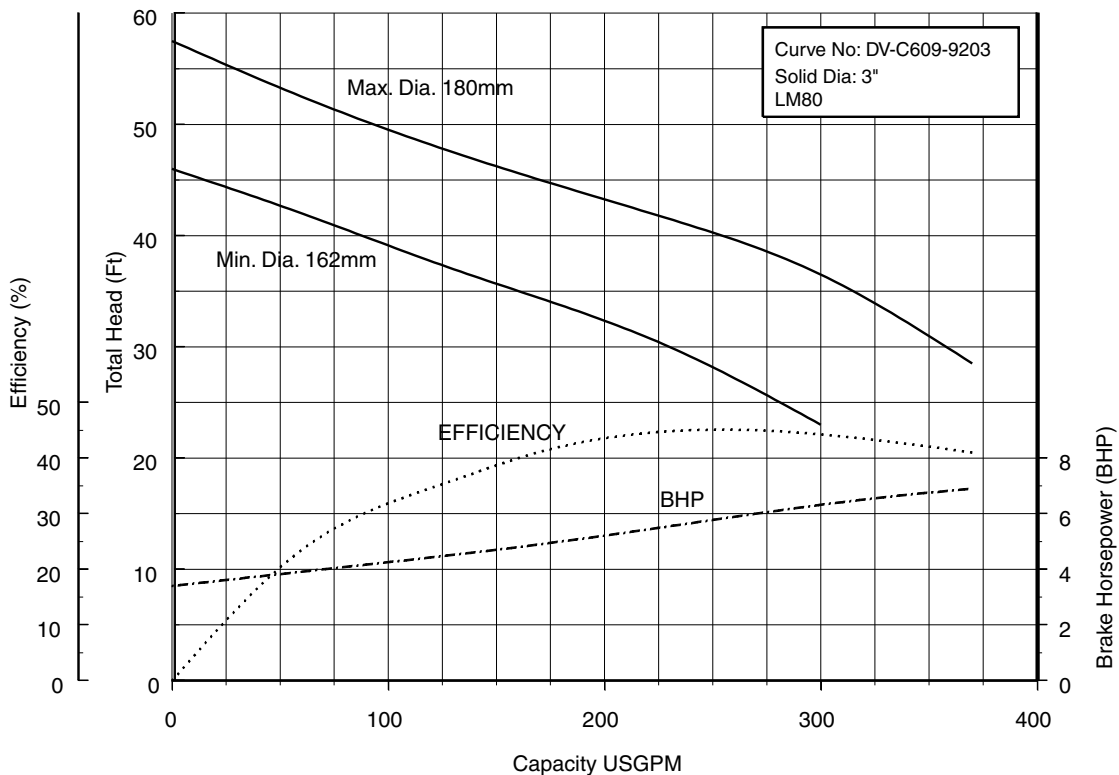

**Performance Curves**

Project: \_\_\_\_\_ GPM: \_\_\_\_\_ TDH: \_\_\_\_\_ EFF: \_\_\_\_\_ HP: \_\_\_\_\_ Chk'd: \_\_\_\_\_ Date: \_\_\_\_\_

**80DVF67.5 (10HP) Synchronous Speed: 1800 RPM**

**3, 4 inch Discharge**

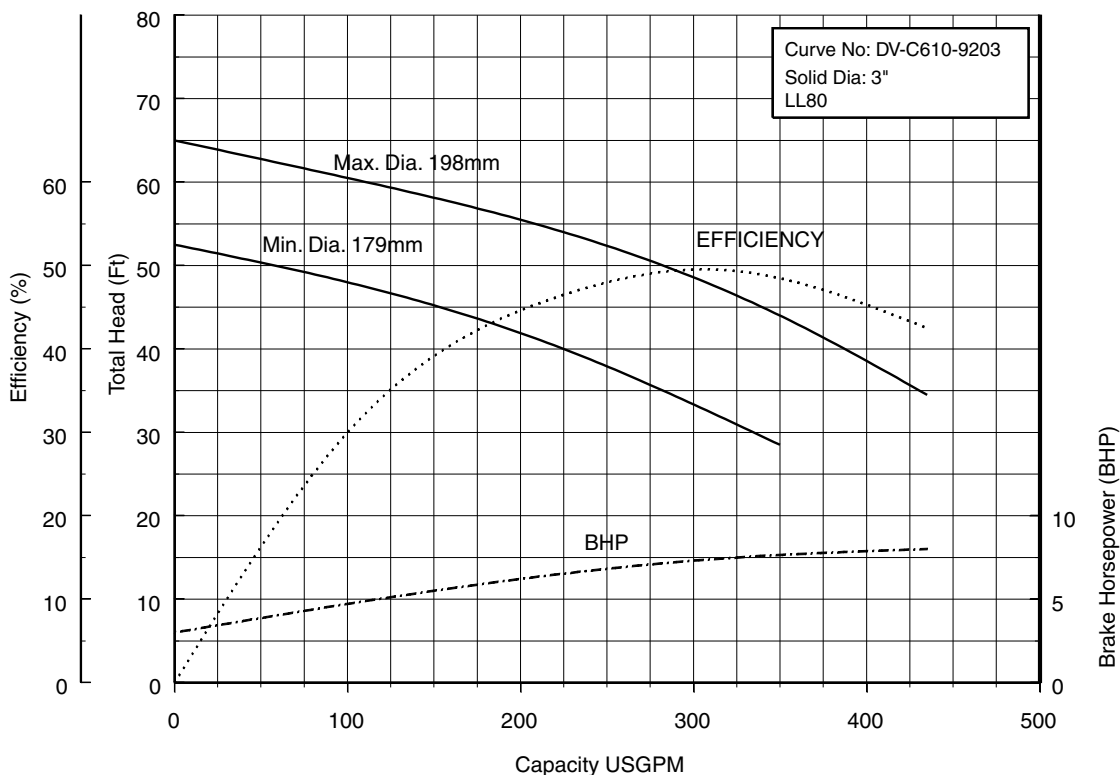

**80DVBF611 (15HP) Synchronous Speed: 1800 RPM**

**3, 4 inch Discharge**

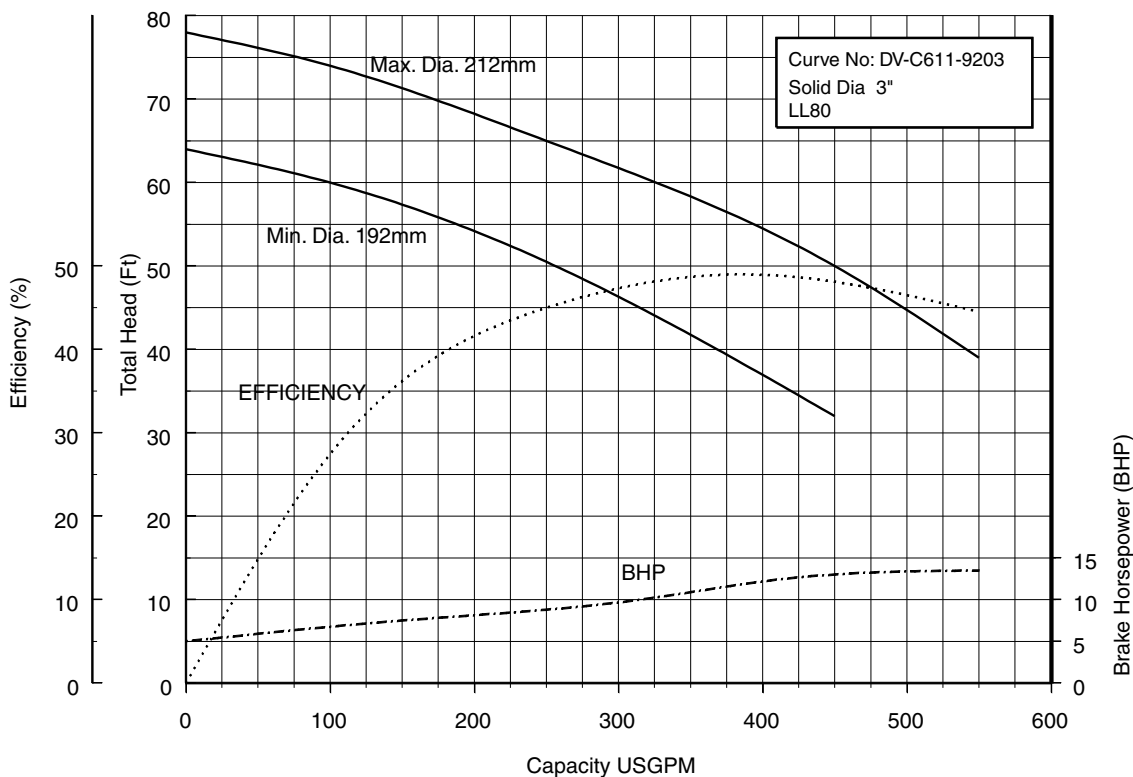

**Performance Curves**

Project: \_\_\_\_\_ GPM: \_\_\_\_\_ TDH: \_\_\_\_\_ EFF: \_\_\_\_\_ HP: \_\_\_\_\_ Chk'd: \_\_\_\_\_ Date: \_\_\_\_\_

**80DVCF611 TO 622 (15 to 30 HP) Synchronous Speed: 1800 RPM 3, 4 inch Discharge**

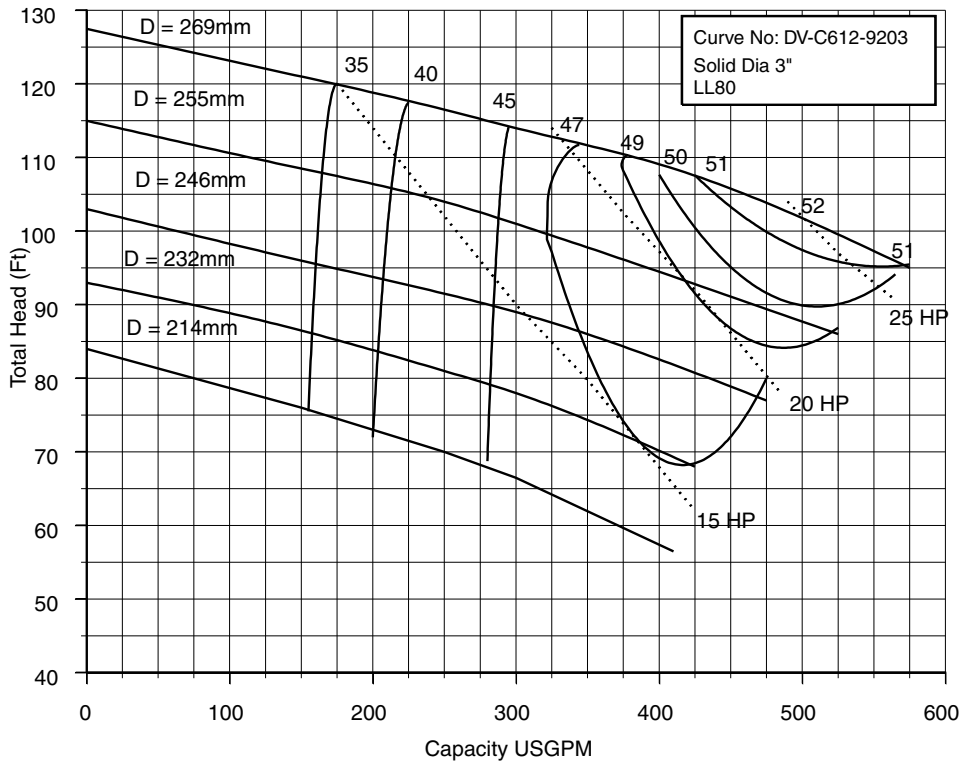

**100DVF63.7 (5HP) Synchronous Speed: 1800 RPM**

**3, 4 inch Discharge**

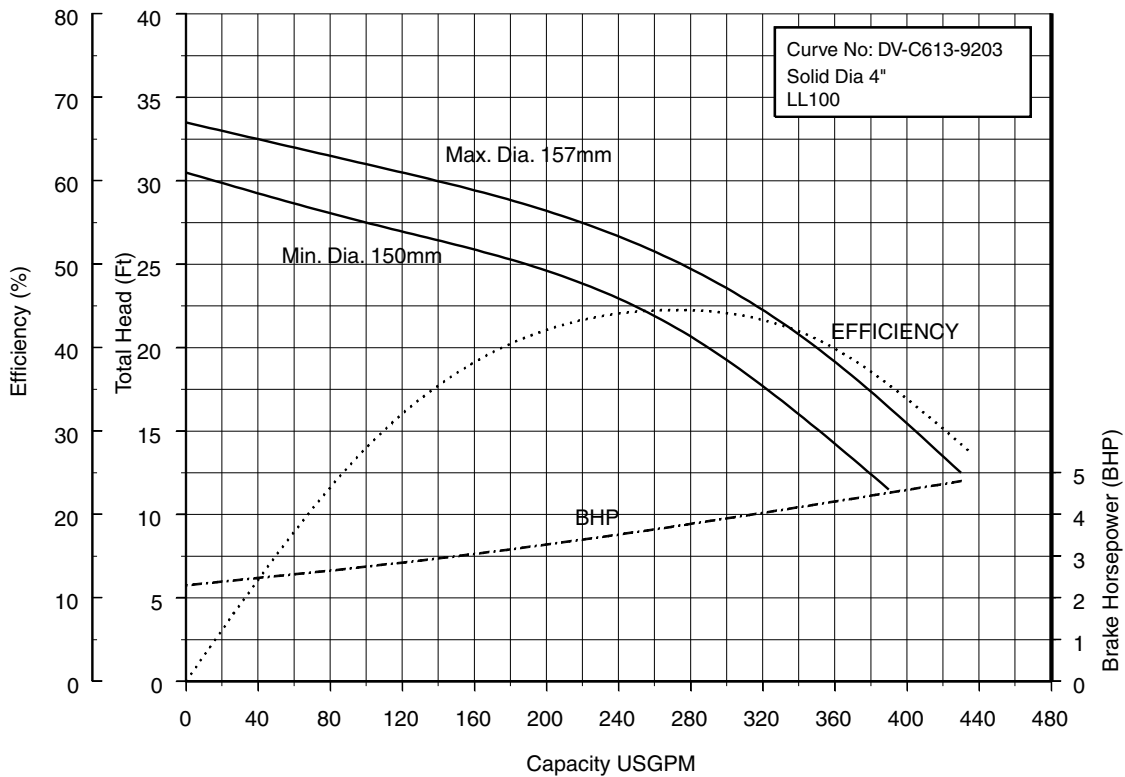

**Performance Curves**

Project: \_\_\_\_\_ GPM: \_\_\_\_\_ TDH: \_\_\_\_\_ EFF: \_\_\_\_\_ HP: \_\_\_\_\_ Chk'd: \_\_\_\_\_ Date: \_\_\_\_\_

**100DVF65.5 (7½HP) Synchronous Speed: 1800 RPM**

**3, 4 inch Discharge**

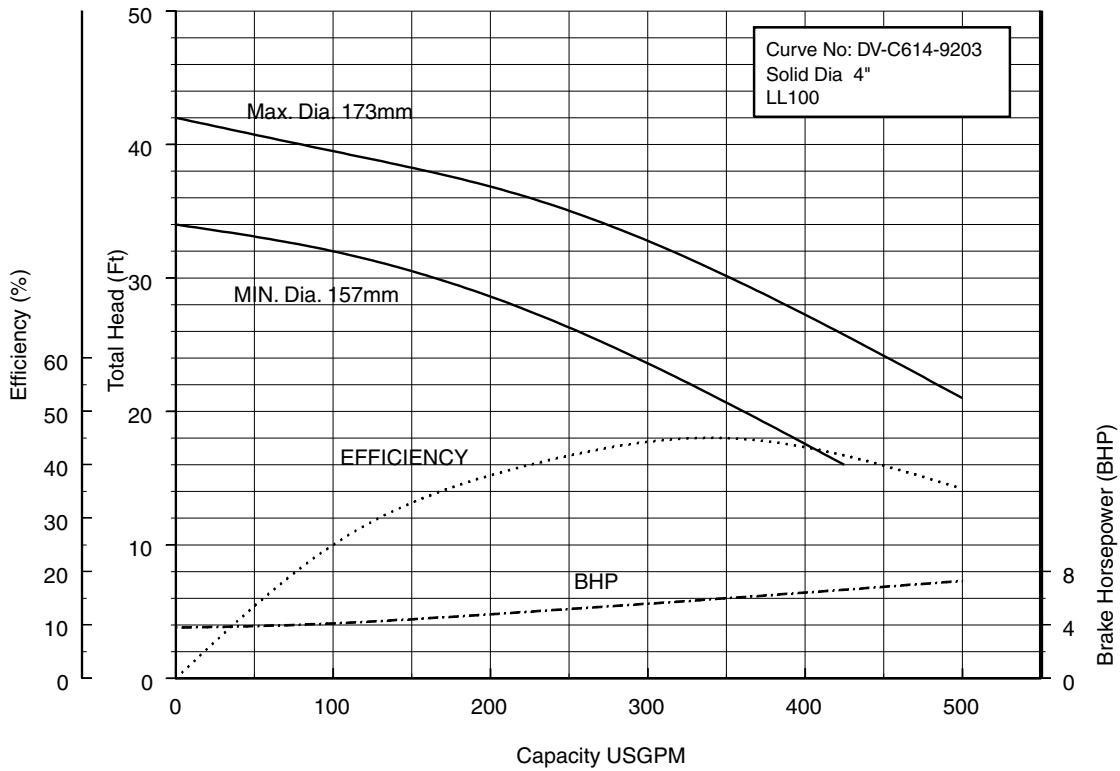

**100DVF67.5 (10HP) Synchronous Speed: 1800 RPM**

**3, 4 inch Discharge**

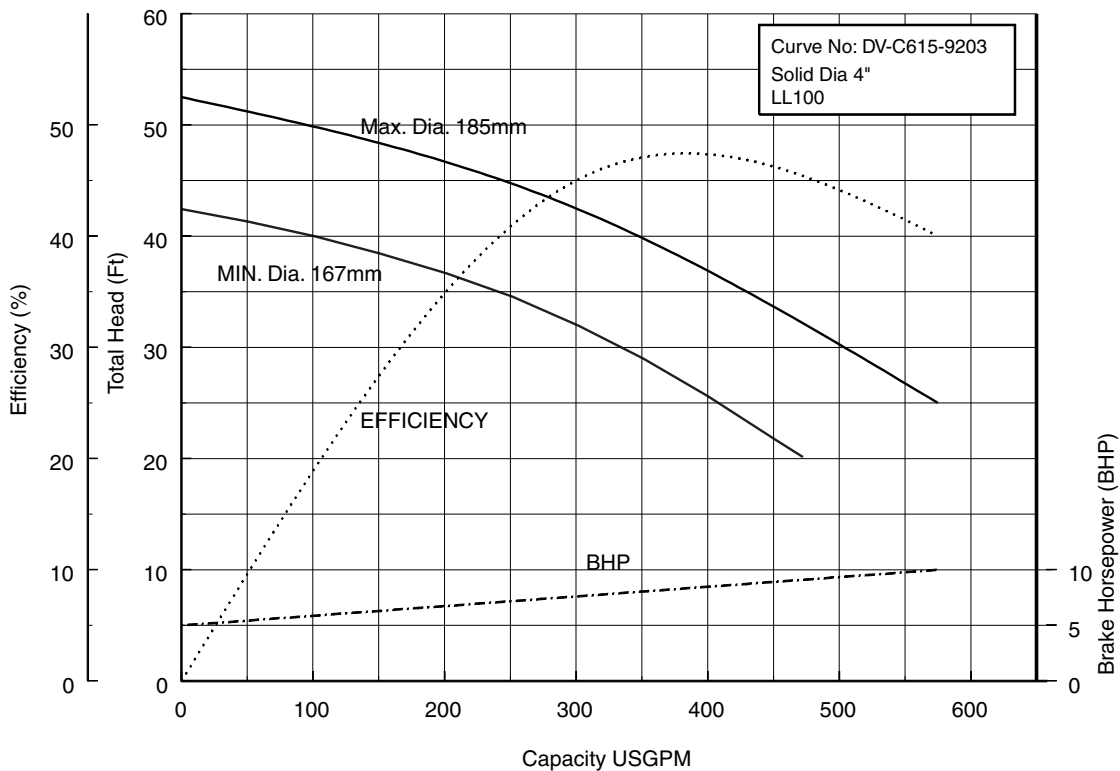

**Performance Curves**

Project: \_\_\_\_\_ GPM: \_\_\_\_\_ TDH: \_\_\_\_\_ EFF: \_\_\_\_\_ HP: \_\_\_\_\_ Chk'd: \_\_\_\_\_ Date: \_\_\_\_\_

**100DVBF611 (15HP) Synchronous Speed: 1800 RPM**

**3, 4 inch Discharge**

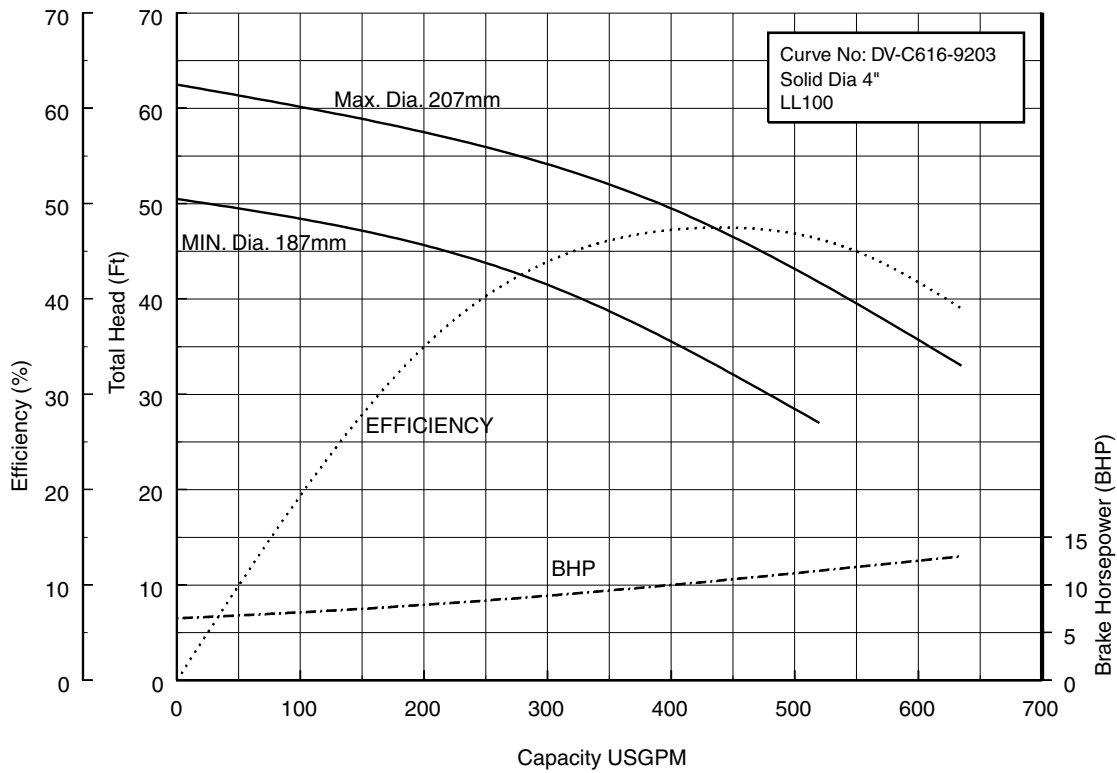

**100DVCF611 to 615 (15 to 20HP) Synchronous Speed: 1800 RPM 3, 4 inch Discharge**

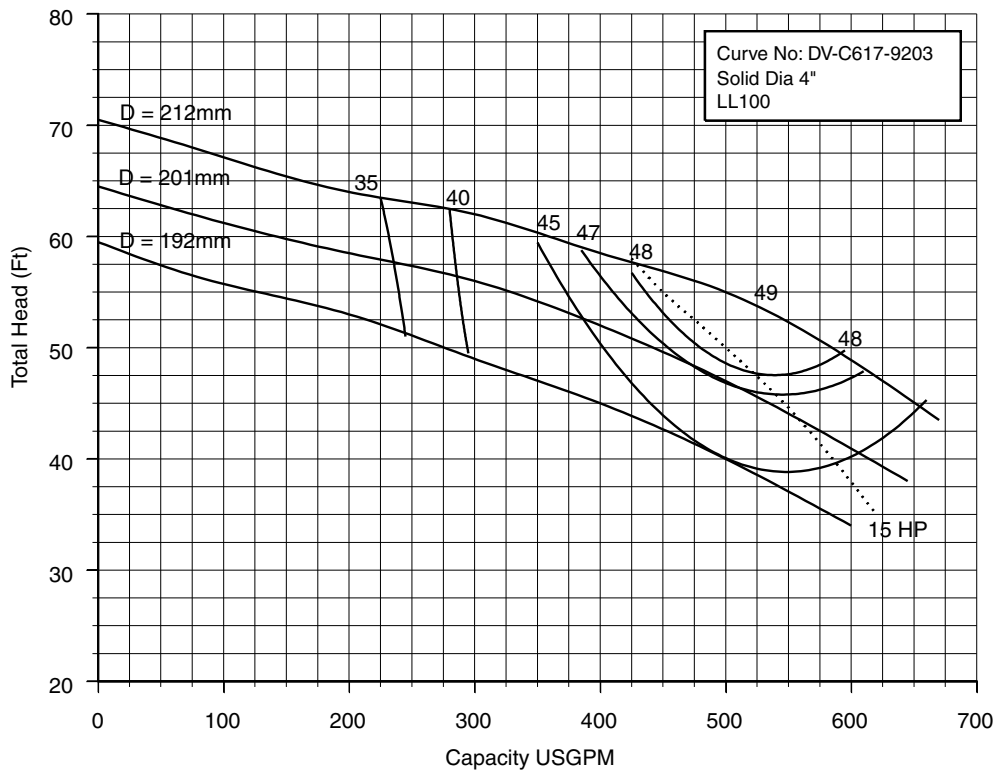



**Performance Curves**

Project: \_\_\_\_\_ GPM: \_\_\_\_\_ TDH: \_\_\_\_\_ EFF: \_\_\_\_\_ HP: \_\_\_\_\_ Chk'd: \_\_\_\_\_ Date: \_\_\_\_\_

**100DVDF611 to 622 (15 to 30HP) Synchronous Speed: 1800 RPM 3, 4 inch Discharge**

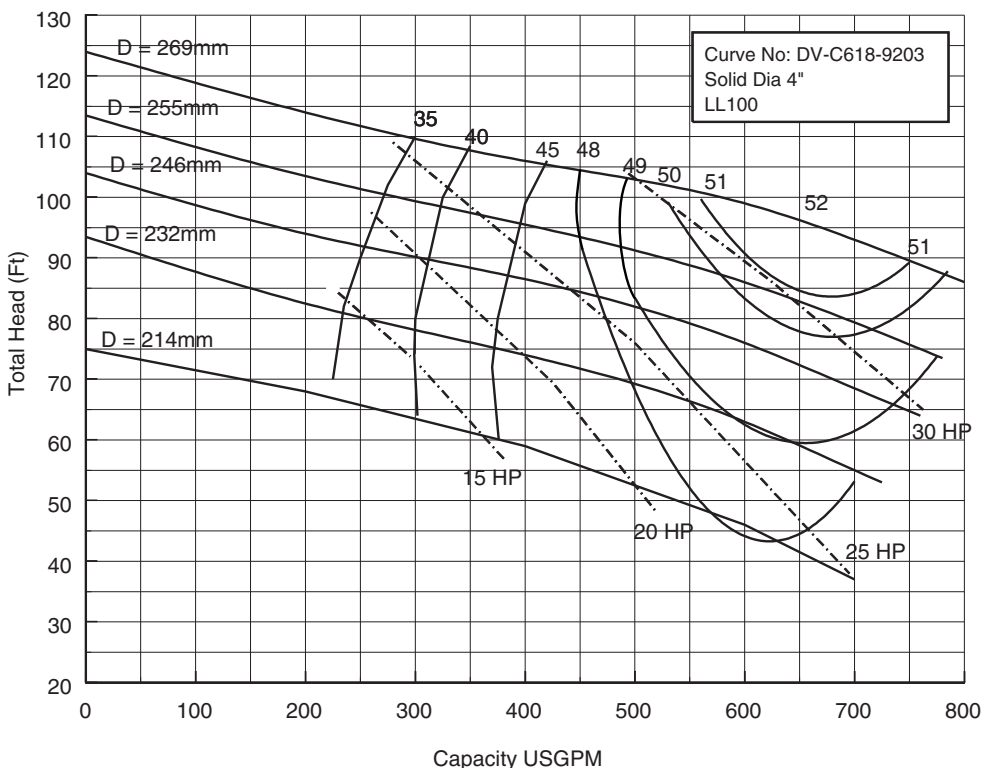

**150DVBF611 to 622 (15 to 30HP) Synchronous Speed: 1800 RPM 4, 6 inch Discharge**

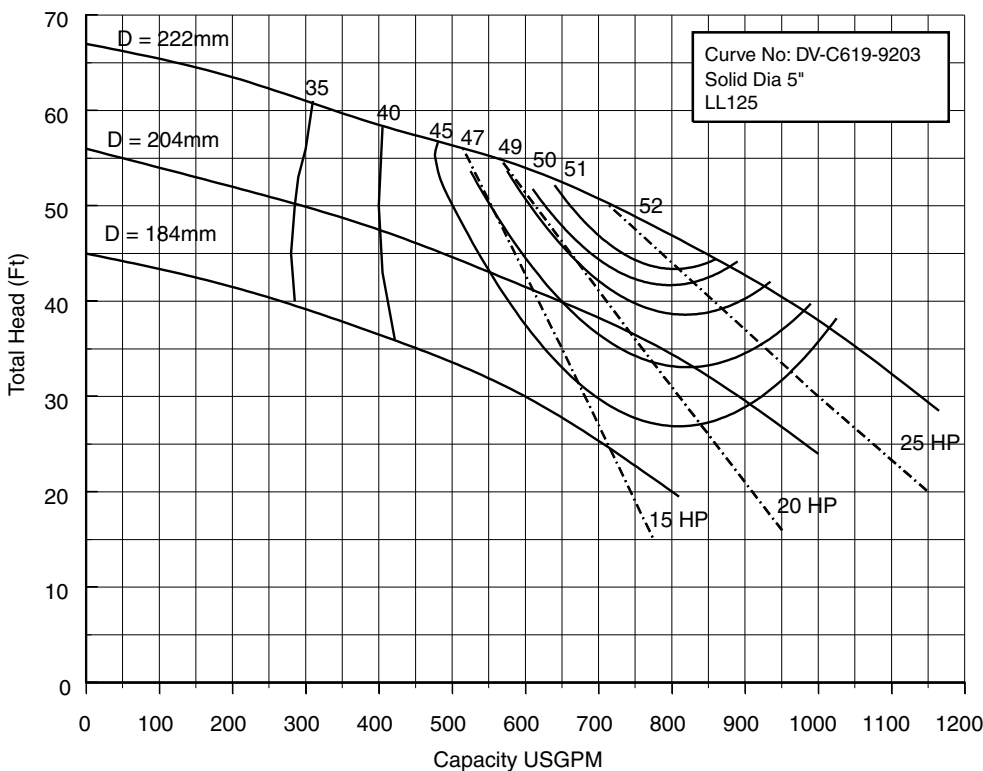

**Performance Curves**

Project: \_\_\_\_\_ GPM: \_\_\_\_\_ TDH: \_\_\_\_\_ EFF: \_\_\_\_\_ HP: \_\_\_\_\_ Chk'd: \_\_\_\_\_ Date: \_\_\_\_\_

**150DVCF618 to 622 (25 to 30HP) Synchronous Speed: 1800 RPM 4, 6 inch Discharge**

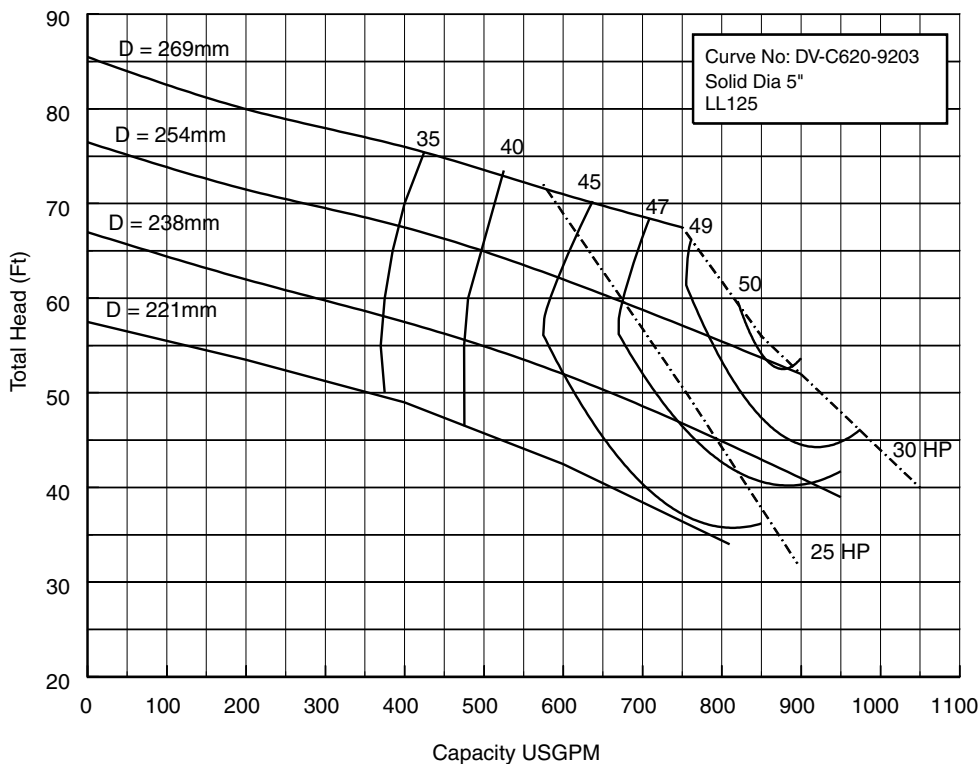

**Dimensions**

Project: \_\_\_\_\_ Model: \_\_\_\_\_ Chk'd: \_\_\_\_\_ Date: \_\_\_\_\_

**Model DVFU  
50DVFU, 2 to 3HP**

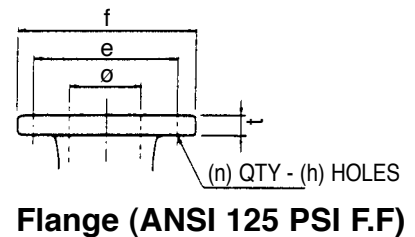
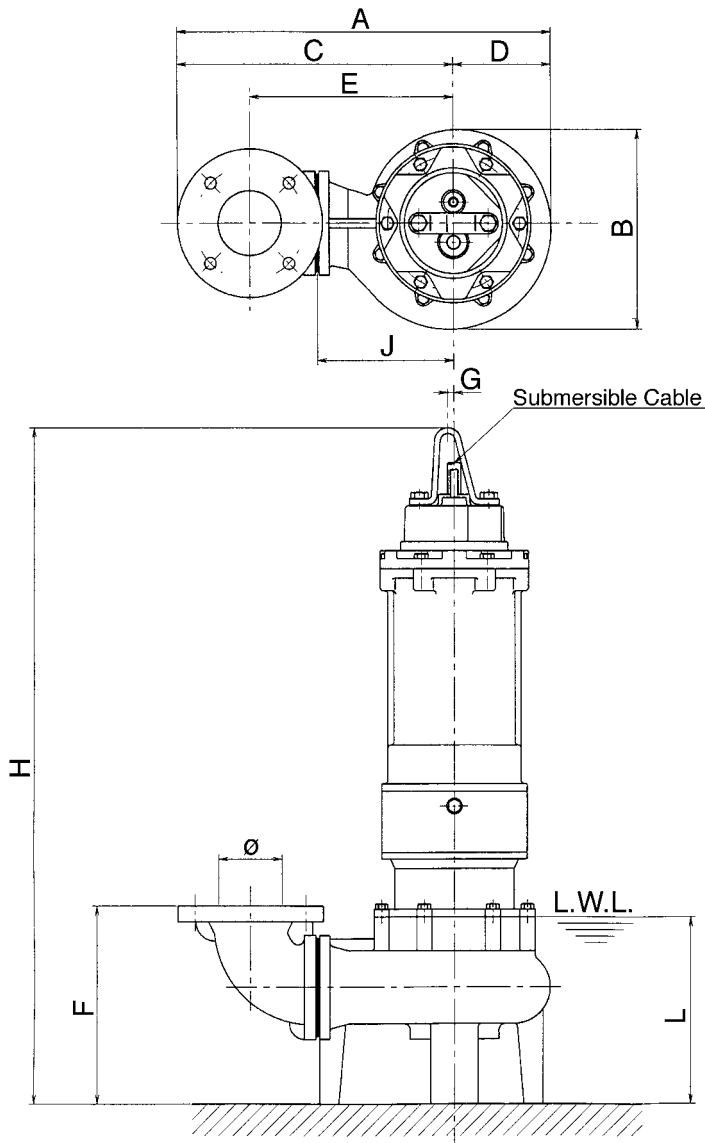

inch					
ø	e	f	t	n	h
2	4 <sup>3</sup> / <sub>4</sub>	6	<sup>5</sup> / <sub>8</sub>	4	<sup>3</sup> / <sub>4</sub>
mm					
ø	e	f	t	n	h
50	121	152	16	4	19

**Dimensions: inch**

PHASE	SIZE ø	MODEL	OUTPUT		PUMP & MOTOR										WEIGHT Lb
			KW	HP	A	B	C	D	E	F	G	H	J	L	
THREE	2	50DVFU61.5	1.5	2	15 <sup>3</sup> / <sub>4</sub>	9 <sup>3</sup> / <sub>8</sub>	11 <sup>1</sup> / <sub>16</sub>	4 <sup>11</sup> / <sub>16</sub>	8 <sup>1</sup> / <sub>16</sub>	7 <sup>5</sup> / <sub>16</sub>	<sup>5</sup> / <sub>16</sub>	28	5 <sup>7</sup> / <sub>8</sub>	6 <sup>7</sup> / <sub>8</sub>	121
		50DVFU62.2	2.2	3	15 <sup>3</sup> / <sub>4</sub>	9 <sup>3</sup> / <sub>8</sub>	11 <sup>1</sup> / <sub>16</sub>	4 <sup>11</sup> / <sub>16</sub>	8 <sup>1</sup> / <sub>16</sub>	7 <sup>5</sup> / <sub>16</sub>	<sup>5</sup> / <sub>16</sub>	29	5 <sup>7</sup> / <sub>8</sub>	6 <sup>7</sup> / <sub>8</sub>	150

**Dimensions: mm**

PHASE	SIZE ø	MODEL	OUTPUT		PUMP & MOTOR										WEIGHT kg
			KW	HP	A	B	C	D	E	F	G	H	J	L	
THREE	50	50DVFU61.5	1.5	2	400	238	281	119	205	185	8	711	150	175	55
		50DVFU62.2	2.2	3	400	238	281	119	205	185	8	737	150	175	68

**Dimensions**

Project: \_\_\_\_\_ Model: \_\_\_\_\_ Chk'd: \_\_\_\_\_ Date: \_\_\_\_\_

**Model DVFU**  
**80DVFU, 2, 7½, 10HP**  
**80DVBFU, 3 to 5HP**  
**80DVCFU, 3 to 5HP**

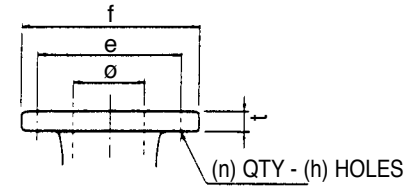
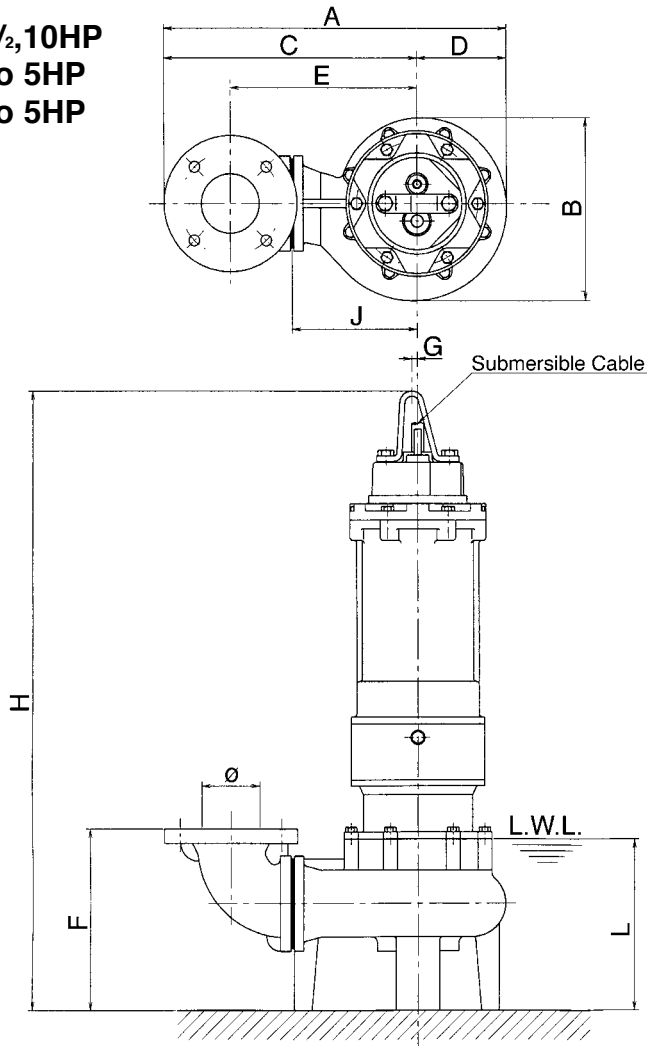

**Flange (ANSI 125 PSI F.F)**

inch					
ø	e	f	t	n	h
2	4 <sup>3</sup> / <sub>4</sub>	6	5 <sup>5</sup> / <sub>8</sub>	4	3 <sup>3</sup> / <sub>4</sub>
3	6	7 <sup>1</sup> / <sub>2</sub>	3 <sup>3</sup> / <sub>4</sub>	4	3 <sup>3</sup> / <sub>4</sub>
4	7 <sup>1</sup> / <sub>2</sub>	9	1 <sup>5</sup> / <sub>16</sub>	8	3 <sup>3</sup> / <sub>4</sub>

mm					
ø	e	f	t	n	h
50	121	152	16	4	19
80	152	191	19	4	19
100	191	229	24	8	19

**Dimensions: inch**

PHASE	SIZE ø	MODEL	OUTPUT		PUMP & MOTOR										WEIGHT Lb
			kW	HP	A	B	C	D	E	F	G	H	J	L	
THREE	2/3	80DVFU61.5	1.5	2	17 <sup>11</sup> / <sub>16</sub>	9 <sup>3</sup> / <sub>8</sub>	13 <sup>1</sup> / <sub>16</sub>	4 <sup>11</sup> / <sub>16</sub>	9 <sup>1</sup> / <sub>4</sub>	8 <sup>13</sup> / <sub>16</sub>	5 <sup>5</sup> / <sub>16</sub>	29 <sup>7</sup> / <sub>16</sub>	6 <sup>5</sup> / <sub>16</sub>	8 <sup>1</sup> / <sub>16</sub>	130
		80DVCFU62.2	2.2	3	17 <sup>11</sup> / <sub>16</sub>	9 <sup>3</sup> / <sub>8</sub>	13 <sup>1</sup> / <sub>16</sub>	4 <sup>11</sup> / <sub>16</sub>	9 <sup>1</sup> / <sub>4</sub>	8 <sup>13</sup> / <sub>16</sub>	5 <sup>5</sup> / <sub>16</sub>	30 <sup>7</sup> / <sub>16</sub>	6 <sup>5</sup> / <sub>16</sub>	8 <sup>1</sup> / <sub>4</sub>	159
		80DVCFU63.7	3.7	5	17 <sup>11</sup> / <sub>16</sub>	9 <sup>3</sup> / <sub>8</sub>	13 <sup>1</sup> / <sub>16</sub>	4 <sup>11</sup> / <sub>16</sub>	9 <sup>1</sup> / <sub>4</sub>	8 <sup>13</sup> / <sub>16</sub>	5 <sup>5</sup> / <sub>16</sub>	32	6 <sup>5</sup> / <sub>16</sub>	8 <sup>1</sup> / <sub>4</sub>	172
	3/4	80DVBFU62.2	2.2	3	18 <sup>9</sup> / <sub>16</sub>	9 <sup>15</sup> / <sub>16</sub>	13 <sup>5</sup> / <sub>8</sub>	4 <sup>15</sup> / <sub>16</sub>	9 <sup>13</sup> / <sub>16</sub>	10	5 <sup>5</sup> / <sub>16</sub>	32 <sup>5</sup> / <sub>16</sub>	6 <sup>7</sup> / <sub>8</sub>	10 <sup>1</sup> / <sub>4</sub>	176
		80DVBFU63.7	3.7	5	18 <sup>9</sup> / <sub>16</sub>	9 <sup>15</sup> / <sub>16</sub>	13 <sup>5</sup> / <sub>8</sub>	4 <sup>15</sup> / <sub>16</sub>	9 <sup>13</sup> / <sub>16</sub>	10	5 <sup>5</sup> / <sub>16</sub>	33 <sup>7</sup> / <sub>8</sub>	6 <sup>7</sup> / <sub>8</sub>	10 <sup>1</sup> / <sub>4</sub>	176
		80DVFU65.5	5.5	7 <sup>1</sup> / <sub>2</sub>	20 <sup>1</sup> / <sub>4</sub>	11 <sup>1</sup> / <sub>4</sub>	14 <sup>5</sup> / <sub>8</sub>	5 <sup>5</sup> / <sub>8</sub>	10 <sup>13</sup> / <sub>16</sub>	10	3 <sup>3</sup> / <sub>8</sub>	39 <sup>1</sup> / <sub>8</sub>	7 <sup>1</sup> / <sub>8</sub>	13	262
80DVFU67.5	7.5	10	20 <sup>1</sup> / <sub>4</sub>	11 <sup>1</sup> / <sub>4</sub>	14 <sup>5</sup> / <sub>8</sub>	5 <sup>5</sup> / <sub>8</sub>	10 <sup>13</sup> / <sub>16</sub>	10	3 <sup>3</sup> / <sub>8</sub>	39 <sup>1</sup> / <sub>8</sub>	7 <sup>1</sup> / <sub>8</sub>	13	291		

**Dimensions: mm**

PHASE	SIZE ø	MODEL	OUTPUT		PUMP & MOTOR										WEIGHT kg
			kW	HP	A	B	C	D	E	F	G	H	J	L	
THREE	50/80	80DVFU61.5	1.5	2	450	238	331	119	235	224	8	747	160	205	59
		80DVCFU62.2	2.2	3	450	238	331	119	235	224	8	773	160	210	72
		80DVCFU63.7	3.7	5	450	238	331	119	235	224	8	813	160	210	78
	80/100	80DVBFU62.2	2.2	3	471	252	346	125	250	254	8	820	175	260	80
		80DVBFU63.7	3.7	5	471	252	346	125	250	254	8	860	175	260	80
		80DVFU65.5	5.5	7 <sup>1</sup> / <sub>2</sub>	514	285	371	143	275	254	10	994	200	330	119
80DVFU67.5	7.5	10	514	285	371	143	275	254	10	994	200	330	132		

**\*Note:** All dimensions are based on 3" discharge.

**Dimensions**

Project: \_\_\_\_\_ Model: \_\_\_\_\_ Chk'd: \_\_\_\_\_ Date: \_\_\_\_\_

**Model DVFU**  
**80DVBFU, 15HP**  
**80DVCFU, 15 to 30HP**

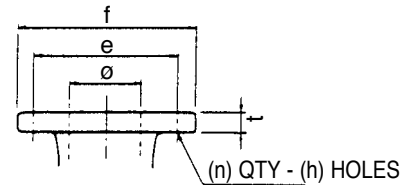
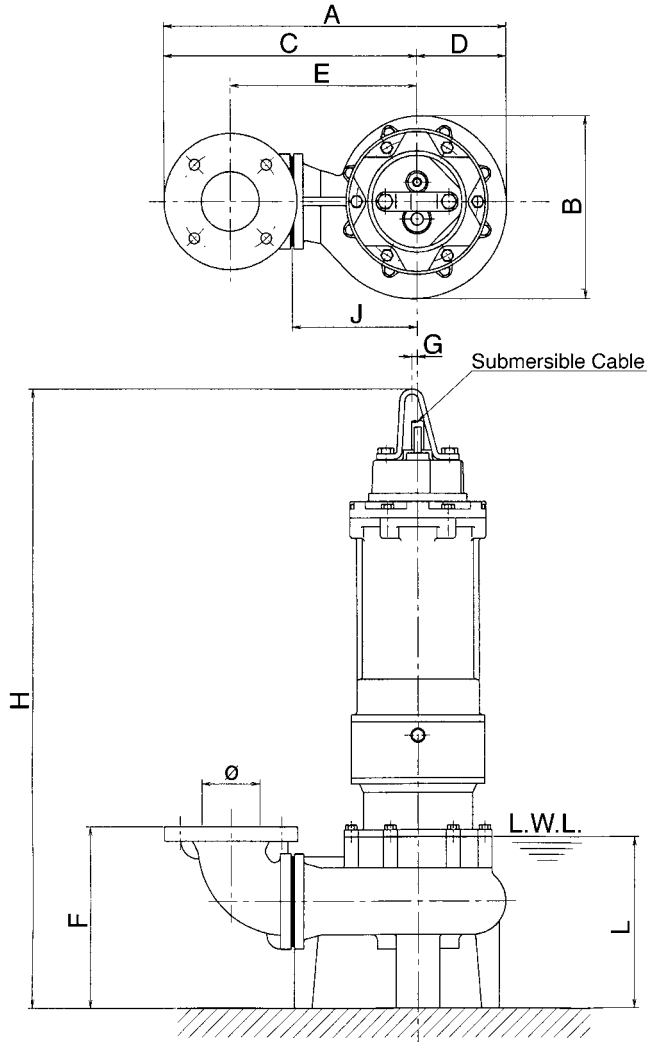

**Flange (ANSI 125 PSI F.F)**

inch					
Ø	e	f	t	n	h
3	6	7 1/2	3/4	4	3/4
4	7 1/2	9	15/16	8	3/4

mm					
Ø	e	f	t	n	h
80	152	191	19	4	19
100	191	229	24	8	19

**Dimensions: inch**

PHASE	SIZE Ø	MODEL	OUTPUT		PUMP & MOTOR										WEIGHT Lb
			kW	HP	A	B	C	D	E	F	G	H	J	L	
THREE	3/4	80DVBFU611	11	15	20 1/4	11 1/4	14 5/8	5 5/8	10 13/16	10	5/16	42 13/16	7 7/8	13	390
		80DVCFU611	11	15	22 15/16	13 7/16	16 3/16	6 3/4	12 3/8	10	5/16	42 13/16	9 7/16	13	406
		80DVCFU61	15	20	22 15/16	13 7/16	16 3/16	6 3/4	12 3/8	10	5/16	45 3/8	9 7/16	13 3/4	503
		5	18.5	25	22 15/16	13 7/16	16 3/16	6 3/4	12 3/8	10	5/16	46 15/16	9 7/16	13 3/4	578
		80DVCFU61	22	30	22 15/16	13 7/16	16 3/16	6 3/4	12 3/8	10	5/16	46 15/16	9 7/16	13 3/4	633

**Dimensions: mm**

PHASE	SIZE Ø	MODEL	OUTPUT		PUMP & MOTOR										WEIGHT kg
			kW	HP	A	B	C	D	E	F	G	H	J	L	
THREE	80/100	80DVBFU611	11	15	514	285	371	143	275	254	8	1087	200	330	177
		80DVCFU611	11	15	582	342	411	171	315	254	8	1087	240	330	184
		80DVCFU61	15	20	582	342	411	171	315	254	8	1152	240	350	228
		5	18.5	25	582	342	411	171	315	254	8	1192	240	350	262
		80DVCFU61	22	30	582	342	411	171	315	254	8	1192	240	350	287

**\*Note:** All dimensions are based on 3" discharge.

**Dimensions**

Project: \_\_\_\_\_ Model: \_\_\_\_\_ Chk'd: \_\_\_\_\_ Date: \_\_\_\_\_

**Model DVFU**  
**100DVFU, 5 to 10HP**  
**100DVBFU, 15HP**

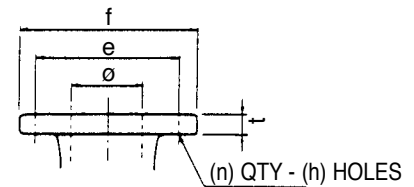
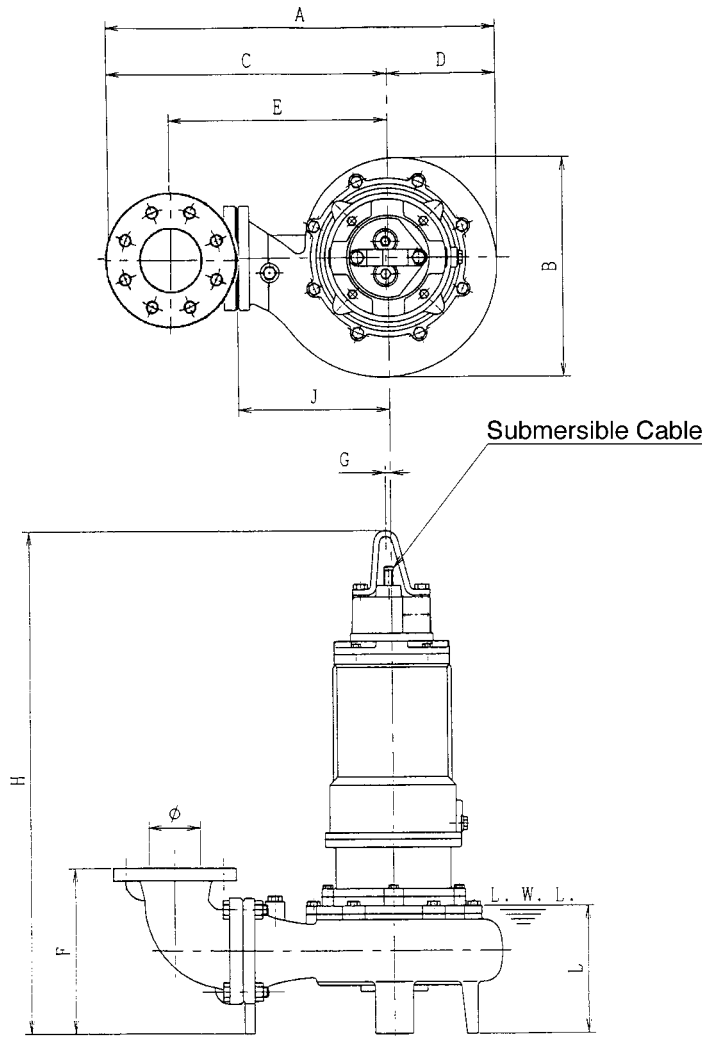

**Flange (ANSI 125 PSI F.F)**

inch					
ø	e	f	t	n	h
3	6	7 1/2	3/4	4	3/4
4	7 1/2	9	15/16	8	3/4

mm					
ø	e	f	t	n	h
80	152	191	19	4	19
100	191	229	24	8	19

**Dimensions: inch**

PHASE	SIZE ø	MODEL	OUTPUT		PUMP & MOTOR										WEIGHT Lb
			kW	HP	A	B	C	D	E	F	G	H	J	L	
THREE	3/4	100DVFU63.7	3.7	5	23 <sup>3</sup> / <sub>16</sub>	12 <sup>1</sup> / <sub>8</sub>	17 <sup>1</sup> / <sub>8</sub>	6 <sup>1</sup> / <sub>16</sub>	12 <sup>5</sup> / <sub>8</sub>	12	5 <sup>9</sup> / <sub>16</sub>	36 <sup>1</sup> / <sub>16</sub>	8 <sup>7</sup> / <sub>16</sub>	12 <sup>3</sup> / <sub>8</sub>	209
		100DVFU65.5	5.5	7 1/2	23 <sup>3</sup> / <sub>16</sub>	12 <sup>1</sup> / <sub>8</sub>	17 <sup>1</sup> / <sub>8</sub>	6 <sup>1</sup> / <sub>16</sub>	12 <sup>5</sup> / <sub>8</sub>	12	3 <sup>3</sup> / <sub>8</sub>	41 <sup>3</sup> / <sub>8</sub>	8 <sup>7</sup> / <sub>16</sub>	15 <sup>1</sup> / <sub>4</sub>	317
		100DVFU67.5	7.5	10	23 <sup>3</sup> / <sub>16</sub>	12 <sup>1</sup> / <sub>8</sub>	17 <sup>1</sup> / <sub>8</sub>	6 <sup>1</sup> / <sub>16</sub>	12 <sup>5</sup> / <sub>8</sub>	12	3 <sup>3</sup> / <sub>8</sub>	41 <sup>3</sup> / <sub>8</sub>	8 <sup>7</sup> / <sub>16</sub>	15 <sup>1</sup> / <sub>4</sub>	346
		100DVBFU611	11	15	23 <sup>3</sup> / <sub>16</sub>	12 <sup>1</sup> / <sub>8</sub>	17 <sup>1</sup> / <sub>8</sub>	6 <sup>1</sup> / <sub>16</sub>	12 <sup>5</sup> / <sub>8</sub>	12	5 <sup>9</sup> / <sub>16</sub>	45 <sup>1</sup> / <sub>16</sub>	8 <sup>7</sup> / <sub>16</sub>	15 <sup>1</sup> / <sub>4</sub>	452

**Dimensions: mm**

PHASE	SIZE	MODEL	OUTPUT		PUMP & MOTOR										WEIGHT kg
			kW	HP	A	B	C	D	E	F	G	H	J	L	
THREE	80/100	100DVFU63.7	3.7	5	589	308	435	154	320	305	8	916	215	315	95
		100DVFU65.5	5.5	7 1/2	589	308	435	154	320	305	10	1051	215	388	144
		100DVFU67.5	7.5	10	589	308	435	154	320	305	10	1051	215	388	157
		100DVBFU611	11	15	589	308	435	154	320	305	8	1144	215	388	205

**Dimensions**

Project: \_\_\_\_\_ Model: \_\_\_\_\_ Chk'd: \_\_\_\_\_ Date: \_\_\_\_\_

**Model DVFU**  
**100DVCFU, 15 to 20HP**  
**100DVDFU, 15 to 30HP**

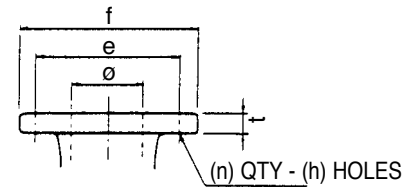
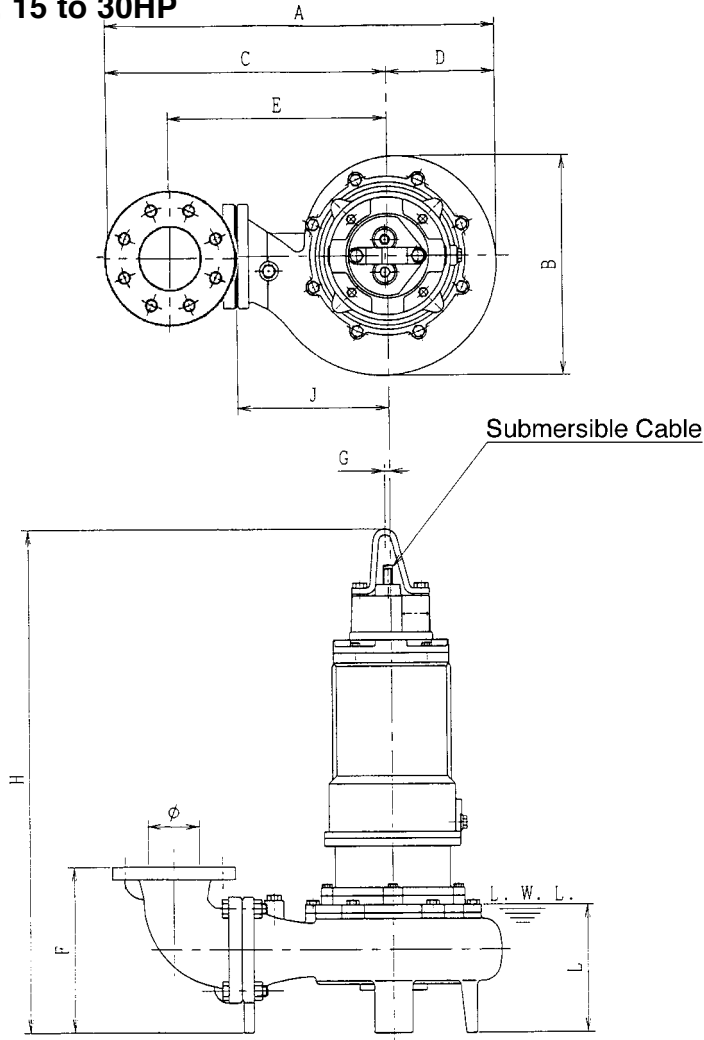

**Flange (ANSI 125 PSI F.F)**

inch					
ø	e	f	t	n	h
3	6	7 1/2	3/4	4	3/4
4	7 1/2	9	15/16	8	3/4

mm					
ø	e	f	t	n	h
80	152	191	19	4	19
100	191	229	24	8	19

**Dimensions: inch**

PHASE	SIZE ø	MODEL	OUTPUT		PUMP & MOTOR										WEIGHT Lb
			kW	HP	A	B	C	D	E	F	G	H	J	L	
THREE	3/4	100DVCFU611	11	15	23 <sup>3/16</sup>	12 <sup>1/8</sup>	17 <sup>1/8</sup>	6 <sup>1/16</sup>	12 <sup>5/8</sup>	12	5/16	45 <sup>1/16</sup>	8 <sup>7/16</sup>	15 <sup>1/4</sup>	452
		100DVCFU61	15	20	23 <sup>3/16</sup>	12 <sup>1/8</sup>	17 <sup>1/8</sup>	6 <sup>1/16</sup>	12 <sup>5/8</sup>	12	5/16	47 <sup>5/8</sup>	8 <sup>7/16</sup>	15 <sup>15/16</sup>	547
		5	11	15	25 <sup>7/16</sup>	13 <sup>7/8</sup>	18 <sup>1/2</sup>	6 <sup>15/16</sup>	14	12	5/16	44 <sup>15/16</sup>	9 <sup>13/16</sup>	15 <sup>1/4</sup>	445
		100DVDFU611	15	20	25 <sup>7/16</sup>	13 <sup>7/8</sup>	18 <sup>1/2</sup>	6 <sup>15/16</sup>	14	12	5/16	47 <sup>1/2</sup>	9 <sup>13/16</sup>	15 <sup>15/16</sup>	547
		100DVDFU61	18.5	25	25 <sup>7/16</sup>	13 <sup>7/8</sup>	18 <sup>1/2</sup>	6 <sup>15/16</sup>	14	12	5/16	49 <sup>1/8</sup>	9 <sup>13/16</sup>	15 <sup>15/16</sup>	602
		5	22	30	25 <sup>7/16</sup>	13 <sup>7/8</sup>	18 <sup>1/2</sup>	6 <sup>15/16</sup>	14	12	5/16	49 <sup>1/8</sup>	9 <sup>13/16</sup>	15 <sup>15/16</sup>	668

**Dimensions: mm**

PHASE	SIZE ø	MODEL	OUTPUT		PUMP & MOTOR										WEIGHT kg
			kW	HP	A	B	C	D	E	F	G	H	J	L	
THREE	80/100	100DVCFU611	11	15	589	308	435	154	320	305	8	1144	215	388	205
		100DVCFU61	15	20	589	308	435	154	320	305	8	1209	215	405	248
		5	11	15	646	352	470	176	355	305	8	1142	250	388	202
		100DVDFU611	15	20	646	352	470	176	355	305	8	1207	250	405	248
		100DVDFU61	18.5	25	646	352	470	176	355	305	8	1247	250	405	273
		5	22	30	646	352	470	176	355	305	8	1247	250	405	303

**Dimensions**

Project: \_\_\_\_\_ Model: \_\_\_\_\_ Chk'd: \_\_\_\_\_ Date: \_\_\_\_\_

**Model DVFU**  
**150DVBFU, 15 to 30HP**  
**150DVCFU, 25 to 30HP**

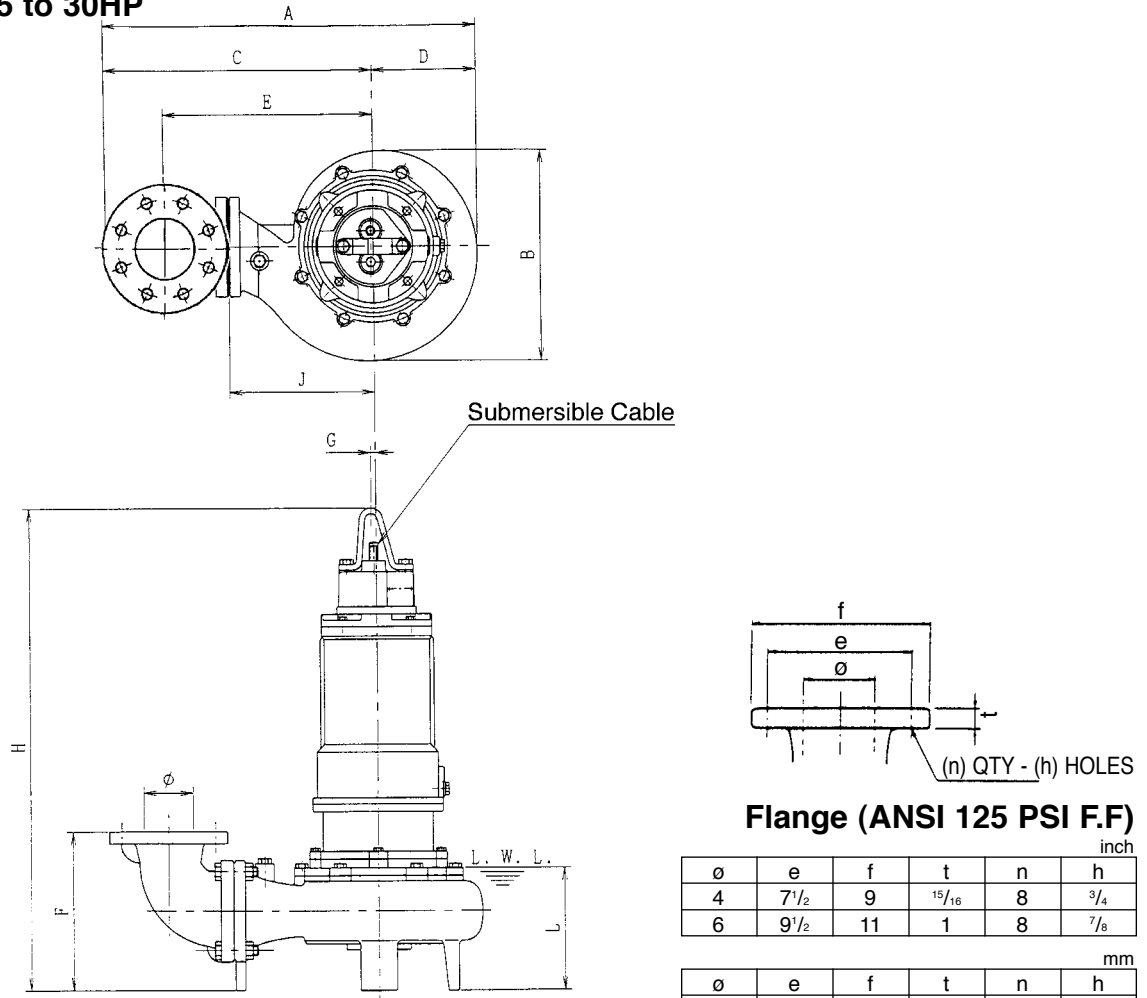

**Flange (ANSI 125 PSI F.F)**

inch					
ø	e	f	t	n	h
4	7 <sup>1</sup> / <sub>2</sub>	9	<sup>15</sup> / <sub>16</sub>	8	<sup>3</sup> / <sub>4</sub>
6	9 <sup>1</sup> / <sub>2</sub>	11	1	8	<sup>7</sup> / <sub>8</sub>

mm					
ø	e	f	t	n	h
100	191	229	24	8	19
150	241	279	25	8	22

**Dimensions: inch**

PHASE	SIZE ø	MODEL	OUTPUT		PUMP & MOTOR										WEIGHT Lb
			kW	HP	A	B	C	D	E	F	G	H	J	L	
THREE	4/6	150DVBFU611	11	15	27 <sup>3</sup> / <sub>8</sub>	13 <sup>1</sup> / <sub>16</sub>	20 <sup>11</sup> / <sub>16</sub>	6 <sup>11</sup> / <sub>16</sub>	15 <sup>9</sup> / <sub>16</sub>	15 <sup>13</sup> / <sub>16</sub>	<sup>5</sup> / <sub>16</sub>	47 <sup>15</sup> / <sub>16</sub>	9 <sup>1</sup> / <sub>4</sub>	18 <sup>7</sup> / <sub>8</sub>	514
		150DVBFU615	15	20	27 <sup>3</sup> / <sub>8</sub>	13 <sup>1</sup> / <sub>16</sub>	20 <sup>11</sup> / <sub>16</sub>	6 <sup>11</sup> / <sub>16</sub>	15 <sup>9</sup> / <sub>16</sub>	15 <sup>13</sup> / <sub>16</sub>	<sup>5</sup> / <sub>16</sub>	50 <sup>1</sup> / <sub>2</sub>	9 <sup>1</sup> / <sub>4</sub>	18 <sup>7</sup> / <sub>8</sub>	608
		150DVBFU618	18.5	25	27 <sup>3</sup> / <sub>8</sub>	13 <sup>1</sup> / <sub>16</sub>	20 <sup>11</sup> / <sub>16</sub>	6 <sup>11</sup> / <sub>16</sub>	15 <sup>9</sup> / <sub>16</sub>	15 <sup>13</sup> / <sub>16</sub>	<sup>5</sup> / <sub>16</sub>	52 <sup>1</sup> / <sub>16</sub>	9 <sup>1</sup> / <sub>4</sub>	18 <sup>7</sup> / <sub>8</sub>	683
		150DVBFU622	22	30	27 <sup>3</sup> / <sub>8</sub>	13 <sup>1</sup> / <sub>16</sub>	20 <sup>11</sup> / <sub>16</sub>	6 <sup>11</sup> / <sub>16</sub>	15 <sup>9</sup> / <sub>16</sub>	15 <sup>13</sup> / <sub>16</sub>	<sup>5</sup> / <sub>16</sub>	52 <sup>1</sup> / <sub>16</sub>	9 <sup>1</sup> / <sub>4</sub>	18 <sup>7</sup> / <sub>8</sub>	739
		150DVCFU61	18.5	25	29 <sup>5</sup> / <sub>8</sub>	15 <sup>1</sup> / <sub>8</sub>	22 <sup>1</sup> / <sub>16</sub>	7 <sup>9</sup> / <sub>16</sub>	16 <sup>9</sup> / <sub>16</sub>	15 <sup>13</sup> / <sub>16</sub>	<sup>5</sup> / <sub>16</sub>	51 <sup>15</sup> / <sub>16</sub>	10 <sup>5</sup> / <sub>8</sub>	18 <sup>7</sup> / <sub>8</sub>	708
		8	22	30	29 <sup>5</sup> / <sub>8</sub>	15 <sup>1</sup> / <sub>8</sub>	22 <sup>1</sup> / <sub>16</sub>	7 <sup>9</sup> / <sub>16</sub>	16 <sup>9</sup> / <sub>16</sub>	15 <sup>13</sup> / <sub>16</sub>	<sup>5</sup> / <sub>16</sub>	51 <sup>15</sup> / <sub>16</sub>	10 <sup>5</sup> / <sub>8</sub>	18 <sup>7</sup> / <sub>8</sub>	763

**Dimensions: mm**

PHASE	SIZE ø	MODEL	OUTPUT		PUMP & MOTOR										WEIGHT kg
			kW	HP	A	B	C	D	E	F	G	H	J	L	
THREE	100/150	150DVBFU611	11	15	695	332	525	170	385	401	8	1218	235	480	233
		150DVBFU615	15	20	695	332	525	170	385	401	8	1283	235	480	276
		150DVBFU618	18.5	25	695	332	525	170	385	401	8	1323	235	480	310
		150DVBFU622	22	30	695	332	525	170	385	401	8	1323	235	480	335
		150DVCFU61	18.5	25	752	384	560	192	420	401	8	1320	270	480	321
		8	22	30	752	384	560	192	420	401	8	1320	270	480	346

**\*Note:** All dimensions are based on 6" discharge.



Dimensions

Project: \_\_\_\_\_ Model: \_\_\_\_\_ Chk'd: \_\_\_\_\_ Date: \_\_\_\_\_

**Model DVFU with Quick Discharge Connector**  
**50DVFU, 2 to 3HP**

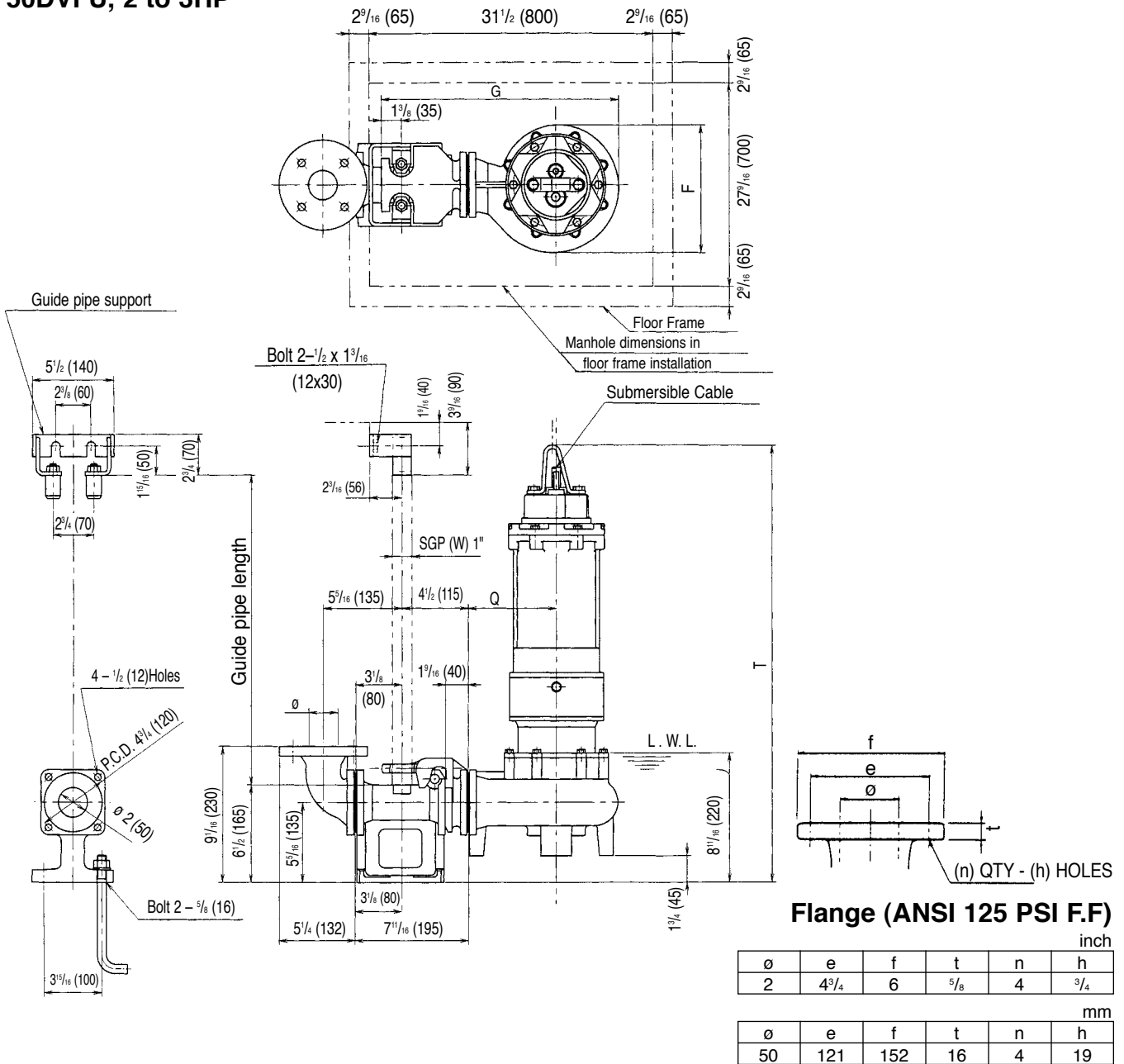

**Dimensions: inch**

PHASE	SIZE ø	MODEL	OUTPUT		Q.D.C. MODEL	PUMP & MOTOR				WEIGHT Lb	
			kW	HP		F	G	Q	T	PUMP	Q.D.C.
THREE	2	50DVFU61.5	1.5	2	LM50	9 <sup>3</sup> / <sub>8</sub>	16 <sup>1</sup> / <sub>4</sub>	5 <sup>7</sup> / <sub>8</sub>	29 <sup>3</sup> / <sub>4</sub>	121	24
		50DVFU62.2	2.2	3	LM50	9 <sup>3</sup> / <sub>8</sub>	15 <sup>1</sup> / <sub>8</sub>	5 <sup>7</sup> / <sub>8</sub>	30 <sup>13</sup> / <sub>16</sub>	150	24

**Dimensions: mm**

PHASE	SIZE ø	MODEL	OUTPUT		Q.D.C. MODEL	PUMP & MOTOR				WEIGHT kg	
			kW	HP		F	G	Q	T	PUMP	Q.D.C.
THREE	50	50DVFU61.5	1.5	2	LM50	238	413	150	756	55	11
		50DVFU62.2	2.2	3	LM50	238	384	150	782	68	11

**Dimensions**

Project: \_\_\_\_\_ Model: \_\_\_\_\_ Chk'd: \_\_\_\_\_ Date: \_\_\_\_\_

**Model DVFU with Quick Discharge Connector**

**80DVFU, 2HP**  
**80DVCFU, 3 to 5HP**

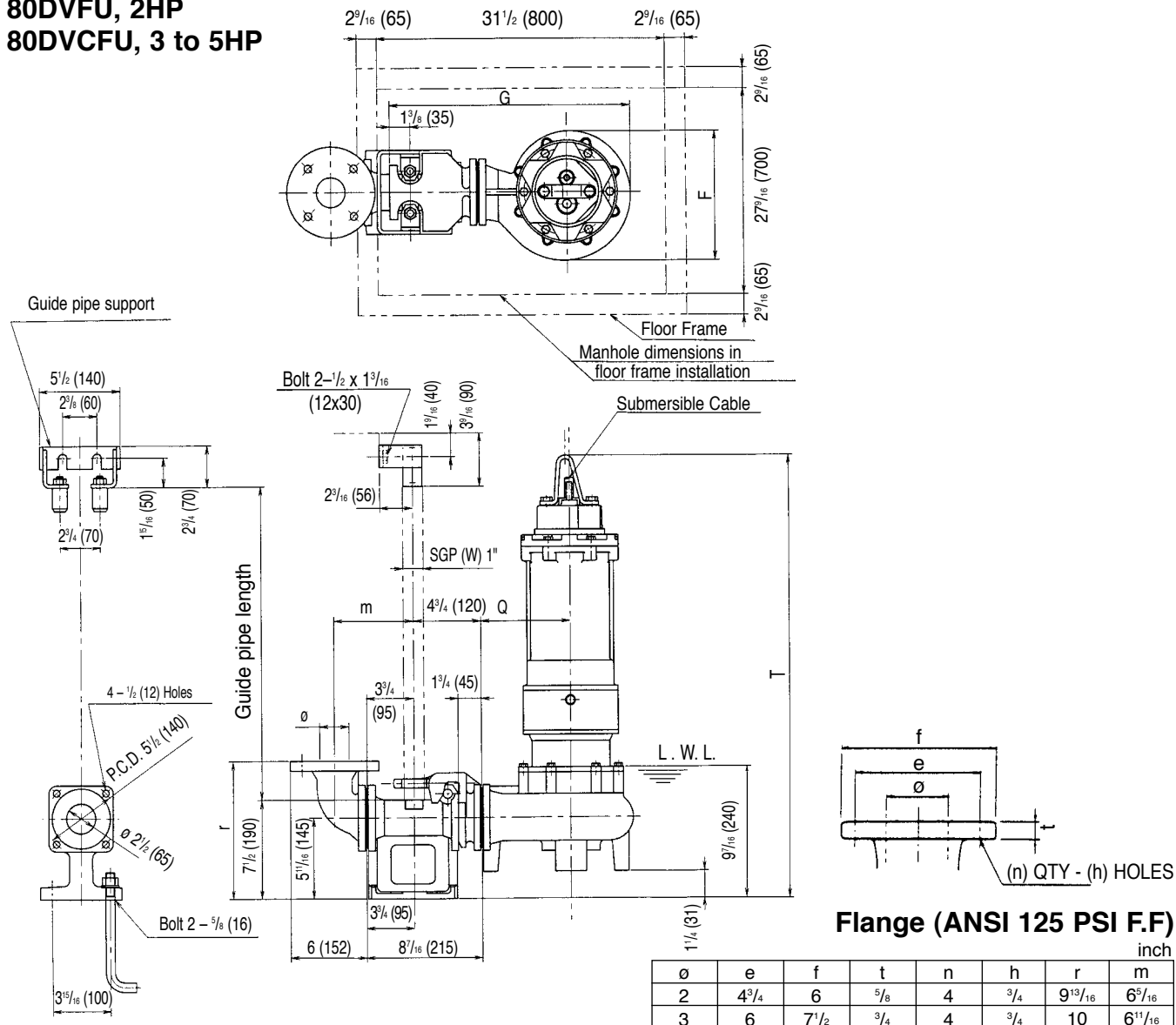

**Flange (ANSI 125 PSI F.F)**

inch							
ø	e	f	t	n	h	r	m
2	4 3/4	6	5/8	4	3/4	9 9/16	6 5/16
3	6	7 1/2	3/4	4	3/4	10	6 11/16
mm							
ø	e	f	t	n	h	r	m
50	121	152	16	4	19	250	161
80	152	191	19	4	19	254	170

**Dimensions: inch**

PHASE	SIZE ø	MODEL	OUTPUT		Q.D.C. MODEL	PUMP & MOTOR				WEIGHT Lb	
			kW	HP		F	G	Q	T	PUMP	Q.D.C.
THREE	2/3	80DVFU61.5	1.5	2	LM65	9 3/8	16 7/8	6 5/16	30 3/8	130	31
		80DVCFU62.	2.2	3	LM65	9 3/8	16 7/8	6 5/16	31 11/16	159	31
		2	3.7	5	LM65	9 3/8	19	6 5/16	33 3/4	172	31

**Dimensions: mm**

PHASE	SIZE ø	MODEL	OUTPUT		Q.D.C. MODEL	PUMP & MOTOR				WEIGHT kg	
			kW	HP		F	G	Q	T	PUMP	Q.D.C.
THREE	50/80	80DVFU61.5	1.5	2	LM65	238	428	160	778	59	14
		80DVCFU62.	2.2	3	LM65	238	428	160	805	72	14
		2	3.7	5	LM65	238	482	160	845	78	14

**\*Note:** All dimensions are based on 3" discharge.

**Dimensions**

Project: \_\_\_\_\_ Model: \_\_\_\_\_ Chk'd: \_\_\_\_\_ Date: \_\_\_\_\_

**Model DVFU with Quick Discharge Connector**  
**80DVBFU, 3 to 5HP**  
**80DVFU, 7½HP**

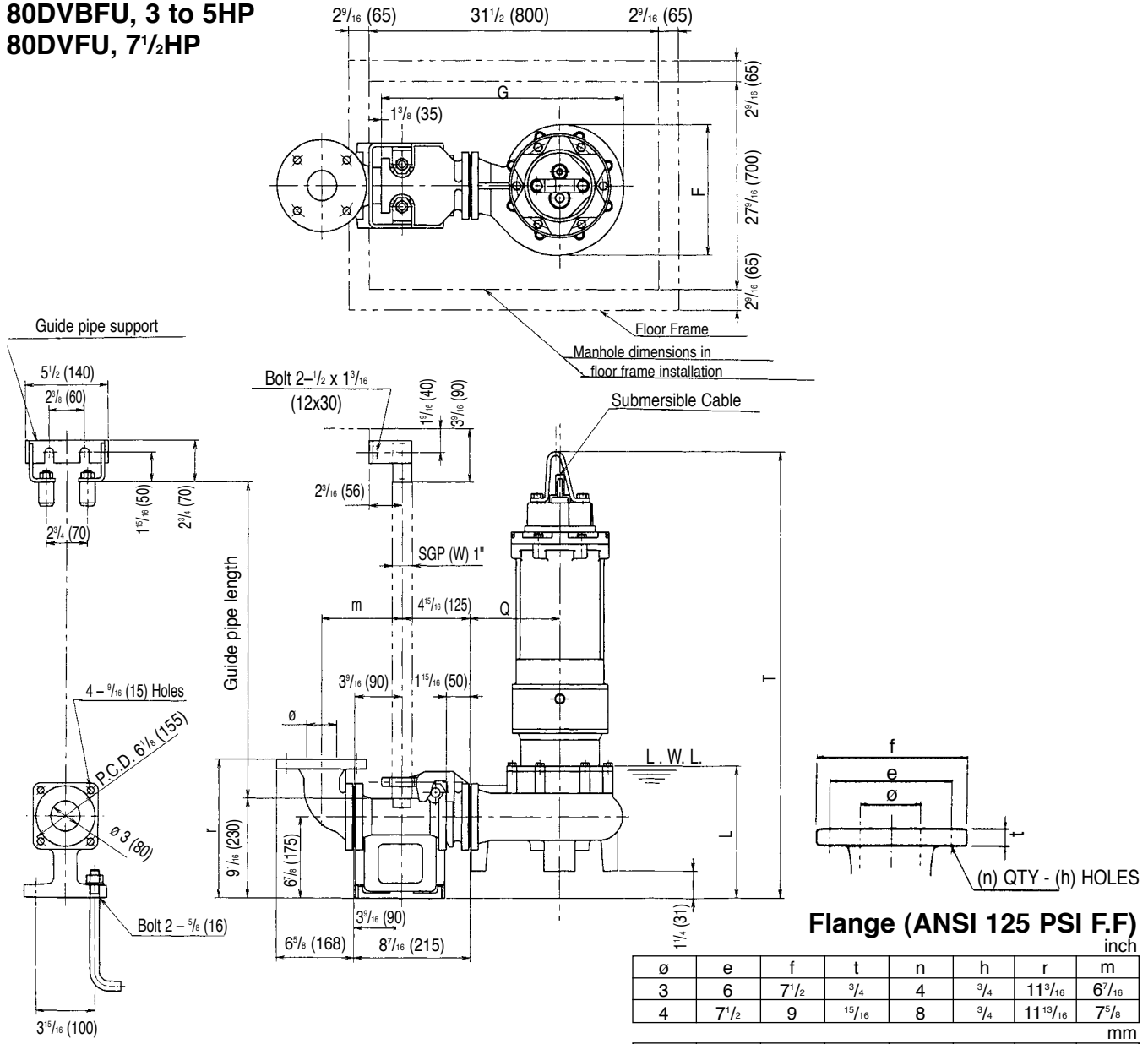

**Dimensions: inch**

PHASE	SIZE ø	MODEL	OUTPUT		Q.D.C. MODEL	PUMP & MOTOR					WEIGHT Lb	
			KW	HP		F	G	L	Q	T	PUMP	Q.D.C.
THREE	3/4	80DVBFU62.2	2.2	3	LM80	9¹⁵/₁₆	18¹/₈	11⁷/₁₆	6⁷/₈	33½	176	37
		80DVBFU63.7	3.7	5	LM80	9¹⁵/₁₆	18¹/₈	11⁷/₁₆	6⁷/₈	35¹/₁₆	176	37
		80DVFU65.5	5.5	7½	LM80	11¼	19¹³/₁₆	14³/₁₆	7⁷/₈	41¹⁵/₁₆	262	37

**Dimensions: mm**

PHASE	SIZE ø	MODEL	OUTPUT		Q.D.C. MODEL	PUMP & MOTOR					WEIGHT kg	
			KW	HP		F	G	L	Q	T	PUMP	Q.D.C.
THREE	80/100	80DVBFU62.2	2.2	3	LM80	252	460	290	175	851	80	17
		80DVBFU63.7	3.7	5	LM80	252	460	290	175	891	80	17
		80DVFU65.5	5.5	7½	LM80	285	503	360	200	1065	119	17

**\*Note:** All dimensions are based on 3" discharge.

**Dimensions**

Project: \_\_\_\_\_ Model: \_\_\_\_\_ Chk'd: \_\_\_\_\_ Date: \_\_\_\_\_

**Model DVFU with Quick Discharge Connector**  
**80DVFU, 10HP**  
**80DVBFU, 15HP**  
**80DVCFU, 15 to 30HP**

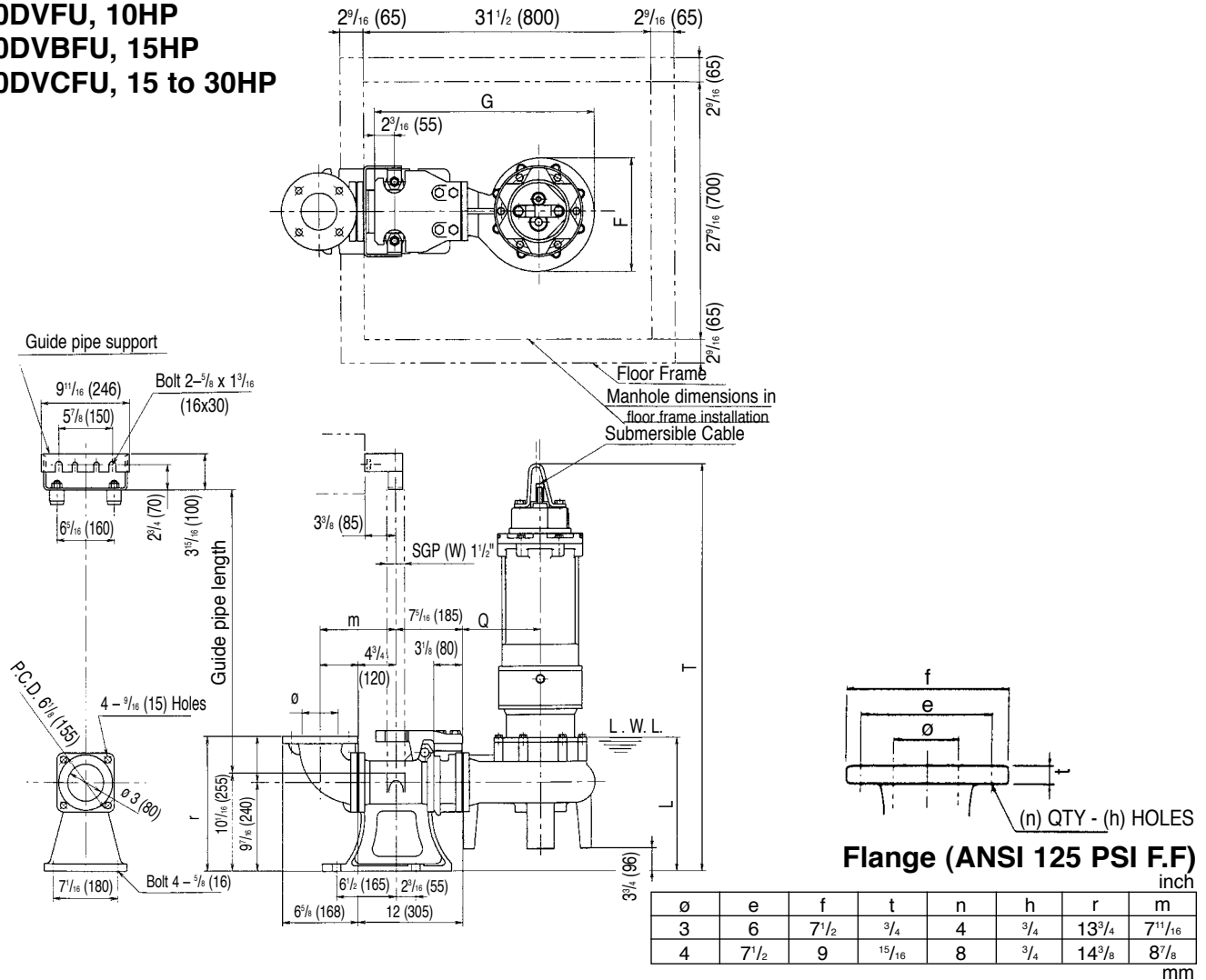

**Flange (ANSI 125 PSI F.F)**

inch	ø	e	f	t	n	h	r	m
	3	6	7 1/2	3/4	4	3/4	13 3/4	7 11/16
	4	7 1/2	9	15/16	8	3/4	14 3/8	8 7/8
mm	ø	e	f	t	n	h	r	m
	80	152	191	19	4	19	350	195
	100	191	229	24	8	19	365	226

**Dimensions: inch**

PHASE	SIZE ø	MODEL	OUTPUT		Q.D.C. MODEL	PUMP & MOTOR				WEIGHT Lb		
			kW	HP		F	G	L	Q	T	PUMP	Q.D.C.
THREE	3/4	80DVFU67.5	7.5	10	LL80	11 1/4	25 5/8	16 15/16	7 7/8	42 15/16	291	97
		80DVBFU611	11	15	LL80	11 1/4	25 5/8	16 15/16	7 7/8	46 9/16	390	97
		80DVCFU611	11	15	LL80	13 7/16	25 5/8	16 15/16	9 7/16	46 9/16	406	97
		80DVCFU615	15	20	LL80	13 7/16	25 5/8	17 11/16	9 7/16	49 1/8	503	97
		80DVCFU618	18.5	25	LL80	13 7/16	25 5/8	17 11/16	9 7/16	50 11/16	578	97
		80DVCFU622	22	30	LL80	13 7/16	25 5/8	17 11/16	9 7/16	50 11/16	633	97

**Dimensions: mm**

PHASE	SIZE ø	MODEL	OUTPUT		Q.D.C. MODEL	PUMP & MOTOR				WEIGHT kg		
			kW	HP		F	G	L	Q	T	PUMP	Q.D.C.
THREE	80/100	80DVFU67.5	7.5	10	LL80	285	651	430	200	1090	132	44
		80DVBFU611	11	15	LL80	285	651	430	200	1183	177	44
		80DVCFU611	11	15	LL80	342	651	430	240	1183	184	44
		80DVCFU615	15	20	LL80	342	651	450	240	1248	228	44
		80DVCFU618	18.5	25	LL80	342	651	450	240	1288	262	44
		80DVCFU622	22	30	LL80	342	651	450	240	1288	287	44

**\*Note:** All dimensions are based on 3" discharge.

**Dimensions**

Project: \_\_\_\_\_ Model: \_\_\_\_\_ Chk'd: \_\_\_\_\_ Date: \_\_\_\_\_

**Model DVFU with Quick Discharge Connector**

**100DVFU, 5 to 10HP**

**100DVBFU, 15HP**

**100DVCFU, 15 to 20HP**

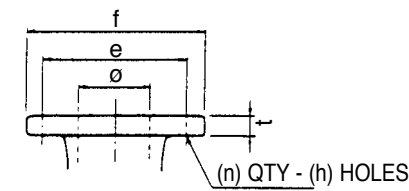
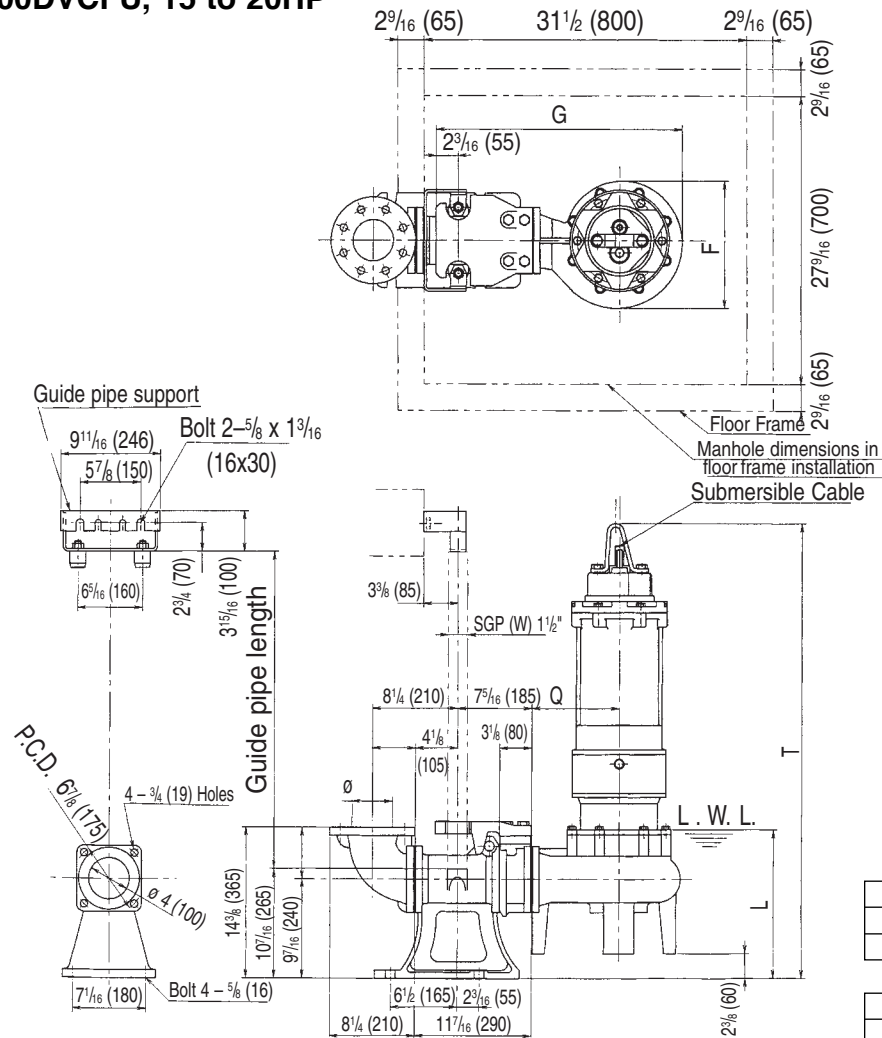

**Flange (ANSI 125 PSI F.F)**

inch					
ø	e	f	t	n	h
3	6	7 1/2	3/4	4	3/4
4	7 1/2	9	15/16	8	3/4

mm					
ø	e	f	t	n	h
80	152	191	19	4	19
100	191	229	24	8	19

**Dimensions: inch**

PHASE	SIZE ø	MODEL	OUTPUT		Q.D.C. MODEL	PUMP & MOTOR					WEIGHT Lb	
			KW	HP		F	G	L	Q	T	PUMP	Q.D.C.
THREE	3/4	100DVFU63.7	3.7	5	LL100	12 1/8	24	14 3/4	8 7/16	38 7/16	209	101
		100DVFU65.5	5.5	7 1/2	LL100	12 1/8	24	17 7/8	8 7/16	43 3/4	317	101
		100DVFU67.5	7.5	10	LL100	12 1/8	24	17 9/8	8 7/16	43 3/4	346	101
		100DVBFU611	11	15	LL100	12 1/8	24	17 7/8	8 7/16	47 3/8	452	101
		100DVCFU611	11	15	LL100	12 1/8	24	17 9/8	8 7/16	47 3/8	452	101
		100DVCFU615	15	20	LL100	12 1/8	24	17 7/8	8 7/16	49 15/16	547	101

**Dimensions: mm**

PHASE	SIZE ø	MODEL	OUTPUT		Q.D.C. MODEL	PUMP & MOTOR					WEIGHT kg	
			KW	HP		F	G	L	Q	T	PUMP	Q.D.C.
THREE	80/100	100DVFU63.7	3.7	5	LL100	308	609	375	215	976	95	46
		100DVFU65.5	5.5	7 1/2	LL100	308	609	448	215	1111	144	46
		100DVFU67.5	7.5	10	LL100	308	609	448	215	1111	157	46
		100DVBFU611	11	15	LL100	308	609	448	215	1204	205	46
		100DVCFU611	11	15	LL100	308	609	448	215	1204	205	46
		100DVCFU615	15	20	LL100	308	609	448	215	1269	248	46

Dimensions

Project: \_\_\_\_\_ Model: \_\_\_\_\_ Chk'd: \_\_\_\_\_ Date: \_\_\_\_\_

Model DVFU with Quick Discharge Connector  
100DVFU, 15 to 30HP

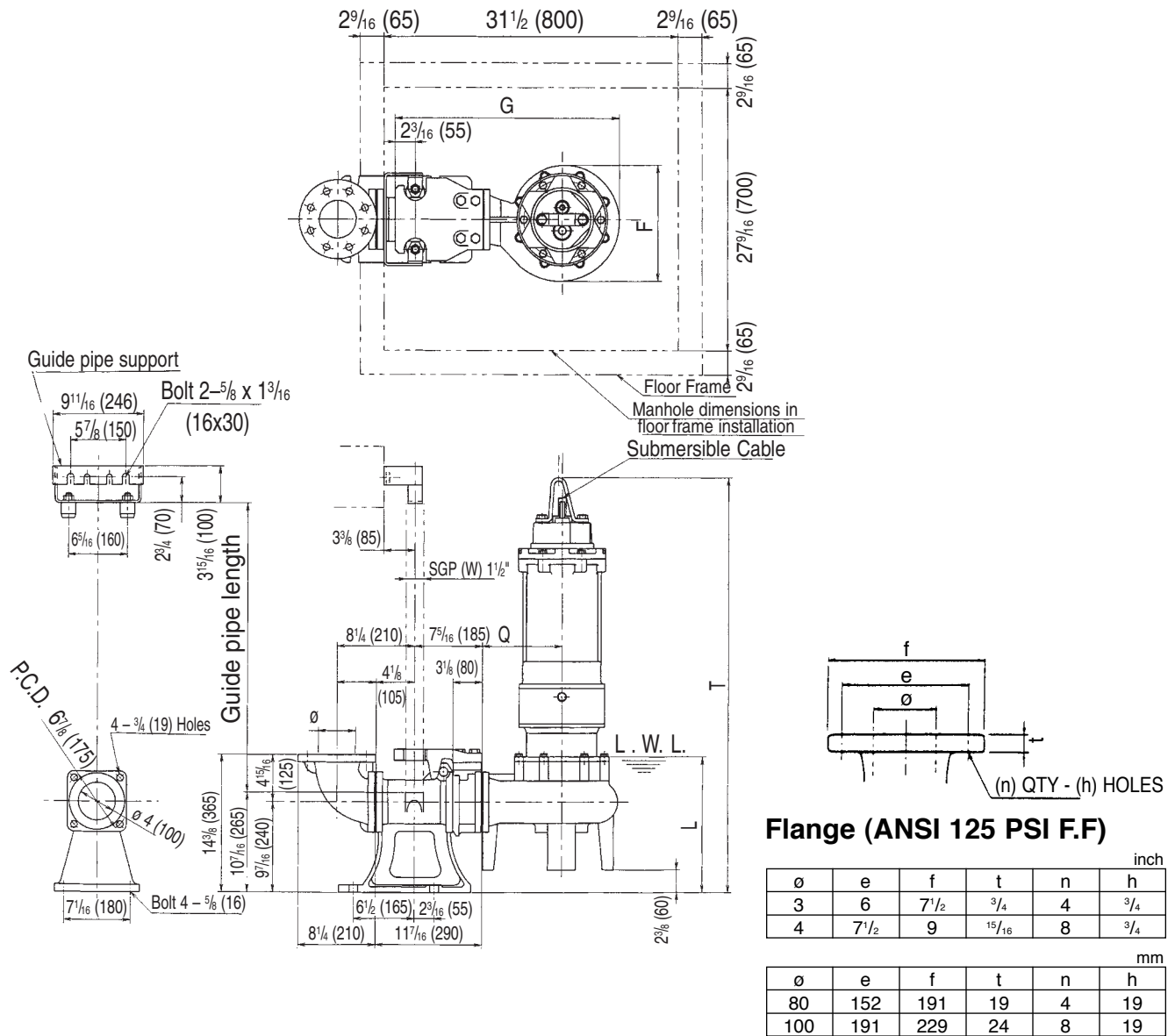

Flange (ANSI 125 PSI F.F)

inch					
ø	e	f	t	n	h
3	6	7 1/2	3/4	4	3/4
4	7 1/2	9	15/16	8	3/4

mm					
ø	e	f	t	n	h
80	152	191	19	4	19
100	191	229	24	8	19

Dimensions: inch

PHASE	SIZE ø	MODEL	OUTPUT		Q.D.C. MODEL	PUMP & MOTOR					WEIGHT Lb	
			kw	HP		F	G	L	Q	T	PUMP	Q.D.C.
THREE	3/4	100DVFU611	11	15	LL100	13 7/8	26 1/4	17 9/16	9 13/16	47 9/16	445	101
		100DVFU61	15	20	LL100	13 7/8	26 1/4	18 5/16	9 13/16	49 7/8	547	101
		5	18.5	25	LL100	13 7/8	26 1/4	18 5/16	9 13/16	51 7/16	602	101
		100DVFU61	22	30	LL100	13 7/8	26 1/4	18 5/16	9 13/16	51 7/16	668	101

Dimensions: mm

PHASE	SIZE ø	MODEL	OUTPUT		Q.D.C. MODEL	PUMP & MOTOR					WEIGHT kg	
			kw	HP		F	G	L	Q	T	PUMP	Q.D.C.
THREE	80/100	100DVFU611	11	15	LL100	352	666	446	250	1202	202	46
		100DVFU61	15	20	LL100	352	666	465	250	1267	248	46
		5	18.5	25	LL100	352	666	465	250	1307	273	46
		100DVFU61	22	30	LL100	352	666	465	250	1307	303	46

**Dimensions**

Project: \_\_\_\_\_ Model: \_\_\_\_\_ Chk'd: \_\_\_\_\_ Date: \_\_\_\_\_

**Model DVFU with Quick Discharge Connector**  
**150DVBFU, 15 to 30HP**  
**150DVCFU, 25 to 30HP**

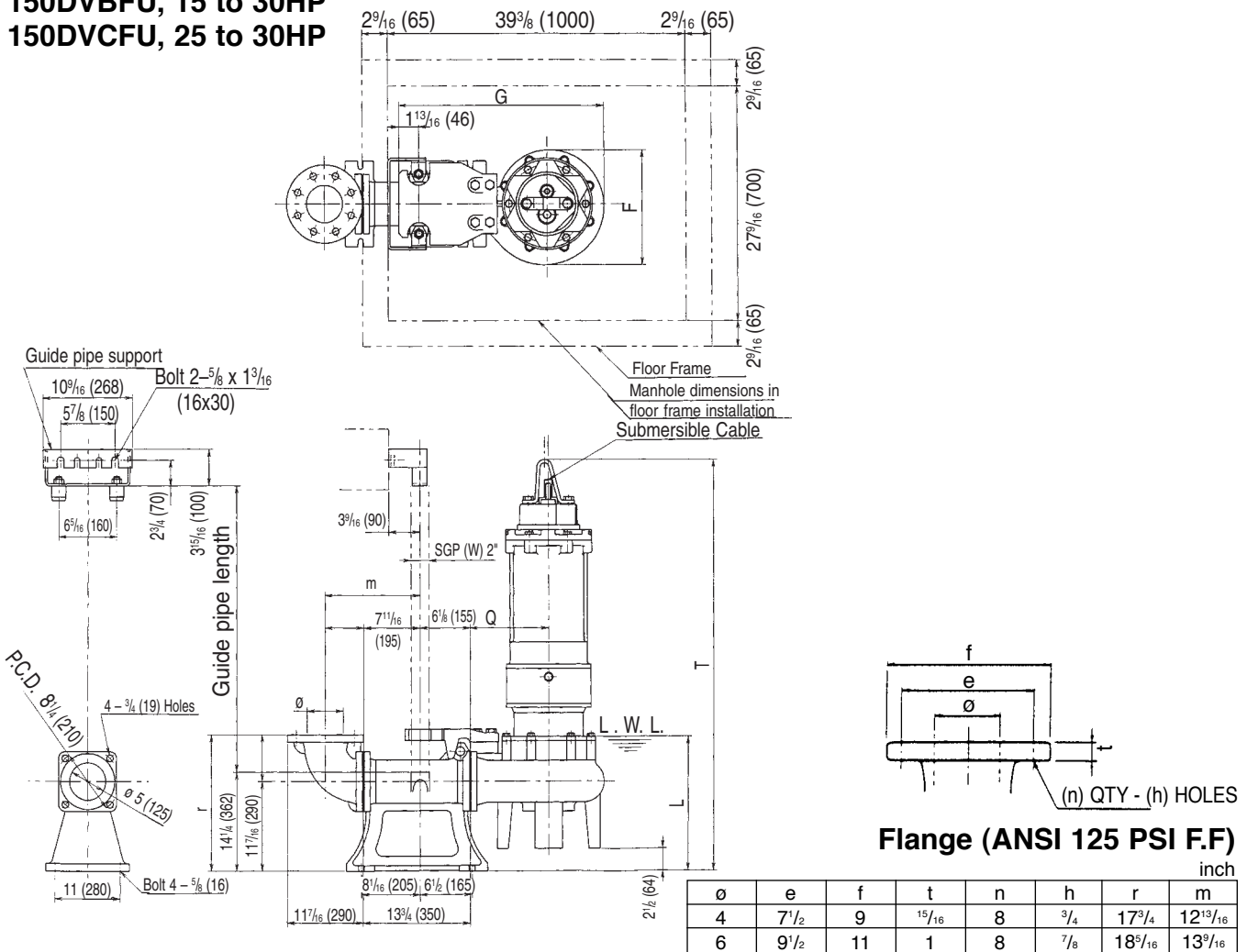

**Flange (ANSI 125 PSI F.F)**

ø	e	f	t	n	h	r	m
4	7 1/2	9	15 1/16	8	3/4	17 3/4	12 13/16
6	9 1/2	11	1	8	7/8	18 5/16	13 3/16

mm							
ø	e	f	t	n	h	r	m
100	191	229	24	8	19	451	326
150	241	279	25	8	22	465	345

**Dimensions: inch**

PHASE	SIZE ø	MODEL	OUTPUT		Q.D.C. MODEL	PUMP & MOTOR					WEIGHT Lb	
			KW	HP		F	G	L	Q	T	PUMP	Q.D.C.
THREE	4/6	150DVBFU611	11	15	LL125	13 1/16	23 11/16	21 9/16	9 1/4	50 1/2	514	143
		150DVBFU615	15	20	LL125	13 1/16	23 11/16	21 9/16	9 1/4	53 1/16	608	143
		150DVBFU618	18.5	25	LL125	13 1/16	23 11/16	21 9/16	9 1/4	54 5/8	683	143
		150DVBFU622	22	30	LL125	13 1/16	23 11/16	21 9/16	9 1/4	54 5/8	739	143
		150DVCFU618	18.5	25	LL125	15 1/8	26 1/8	21 7/16	10 5/8	54 1/2	708	143
		150DVCFU622	22	30	LL125	15 1/8	26 1/8	21 7/16	10 5/8	54 1/2	763	143

**Dimensions: mm**

PHASE	SIZE ø	MODEL	OUTPUT		Q.D.C. MODEL	PUMP & MOTOR					WEIGHT kg	
			KW	HP		F	G	L	Q	T	PUMP	Q.D.C.
THREE	100/150	150DVBFU611	11	15	LL125	332	602	547	235	1283	233	65
		150DVBFU615	15	20	LL125	332	602	547	235	1348	276	65
		150DVBFU618	18.5	25	LL125	332	602	547	235	1387	310	65
		150DVBFU622	22	30	LL125	332	602	547	235	1387	335	65
		150DVCFU618	18.5	25	LL125	384	663	544	270	1384	321	65
		150DVCFU622	22	30	LL125	384	663	544	270	1384	346	65



**Sectional View**

Project:

Model:

Chk'd:

Date:

**2 to 5HP**

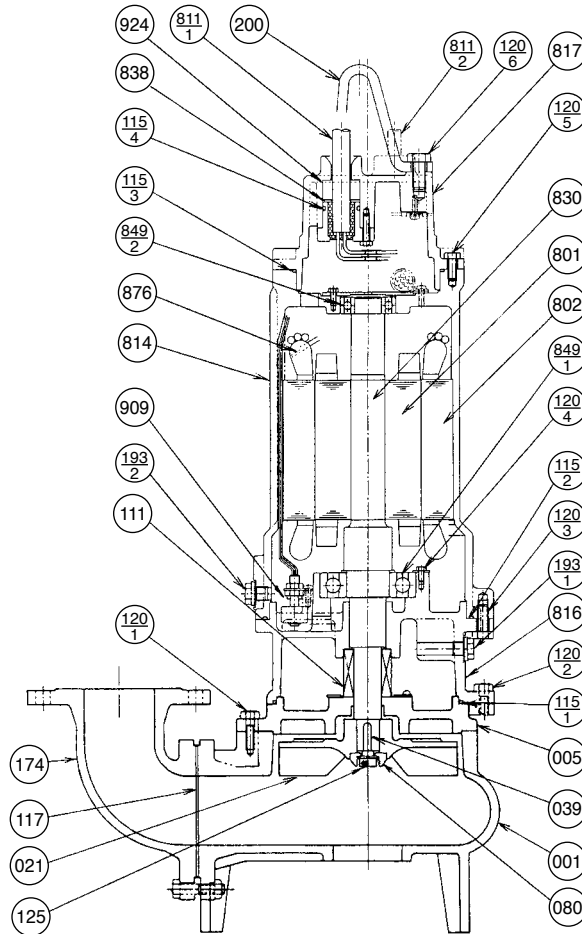

PART NO.	PART NAME	MATERIAL	ASTM, AISI CODE	NO. FOR 1 UNIT
001	CASING	CAST IRON	A48 Class 30	1
005	INTERMEDIATE CASING	CAST IRON	A48 Class 30	1
†021	IMPELLER	CAST IRON	A48 Class 30	1
039	KEY	420 STAINLESS	AISI420	1
080	BUSHING	STEEL	A283 Grade D	1
†111	MECHANICAL SEAL	—		1 SET
†115-1	O-RING	RUBBER (NBR)		1
†115-2	O-RING	RUBBER (NBR)		1
†115-3	O-RING	RUBBER (NBR)		1
†115-4	O-RING	RUBBER (NBR)		2
†117	GASKET			1
120-1	BOLT	304 STAINLESS	AISI304	4
120-2	BOLT	304 STAINLESS	AISI304	4
120-3	BOLT	304 STAINLESS	AISI304	4
120-4	BOLT	304 STAINLESS	AISI304	3
120-5	BOLT	304 STAINLESS	AISI304	4
120-6	BOLT	304 STAINLESS	AISI304	2
125	BOLT	304 STAINLESS	AISI304	1

PART NO.	PART NAME	MATERIAL	ASTM, AISI CODE	NO. FOR 1 UNIT
174	DISCHARGE ELBOW	CAST IRON	A48 Class 30	1
193-1	PLUG	304 STAINLESS	AISI304	1
193-2	PLUG	304 STAINLESS	AISI304	1
200	LIFTING HANGER	STEEL	A283 Grade D	1
801	ROTOR	—		1
802	STATOR	—		1
811-1	POWER CABLE	—		1
811-2	CONTROL CABLE	—		1
814	MOTOR COVER	CAST IRON	A48 Class 30	1
816	BRACKET	CAST IRON	A48 Class 30	1
817	BRACKET	CAST IRON	A48 Class 30	1
830	SHAFT	403 STAINLESS	AISI403	1
838	WASHER	304 STAINLESS	AISI304	2
†849-1	BALL BEARING	—		1
†849-2	BALL BEARING	—		1
876	MOTOR PROTECTOR	—		3
909	LEAKAGE DETECTOR	—		1
924	PACKING	RUBBER (NBR)		2

Motors are purchased as a complete unit

†: Recommended spare parts



**EBARA Fluid Handling**  
 www.pumpsebara.com  
 (t) 803 327 5005 , (f) 803 327 5097



**Sectional View**

Project:

Model:

Chk'd:

Date:

**7½ to 10HP**

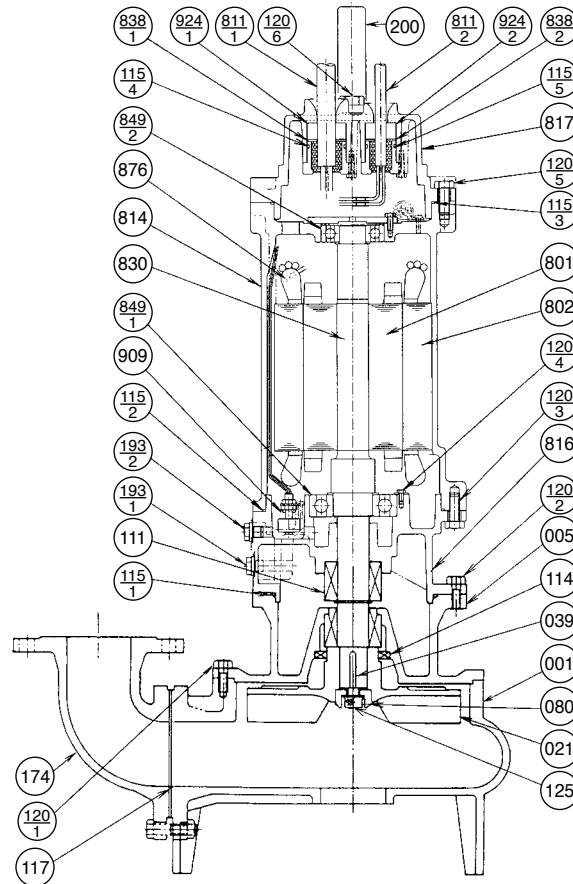

PART NO.	PART NAME	MATERIAL	ASTM, AISI CODE	NO. FOR 1 UNIT	PART NO.	PART NAME	MATERIAL	ASTM, AISI CODE	NO. FOR 1 UNIT
001	CASING	CAST IRON	A48 Class 30	1	174	DISCHARGE ELBOW	CAST IRON	A48 Class 30	1
005	INTERMEDIATE CASING	CAST IRON	A48 Class 30	1	193-1	PLUG	304 STAINLESS	AISI304	1
021	IMPELLER	CAST IRON	A48 Class 30	1	193-2	PLUG	304 STAINLESS	AISI304	1
039	KEY	420 STAINLESS	AISI420	1	200	LIFTING HANGER	STEEL	A283 Grade D	1
080	BUSHING	STEEL	A283 Grade D	1	801	ROTOR	—		1
†111	MECHANICAL SEAL	—		1 SET	802	STATOR	—		1
†114	OIL SEAL	RUBBER (NBR)		1	811-1	POWER CABLE	—		1
†115-1	O-RING	RUBBER (NBR)		1	811-2	CONTROL CABLE	—		1
†115-2	O-RING	RUBBER (NBR)		1	814	MOTOR COVER	CAST IRON	A48 Class 30	1
†115-3	O-RING	RUBBER (NBR)		1	816	BRACKET	CAST IRON	A48 Class 30	1
†115-4	O-RING	RUBBER (NBR)		1	817	BRACKET	CAST IRON	A48 Class 30	1
†115-5	O-RING	RUBBER (NBR)		1	830	SHAFT	420J2 STAINLESS	AISI420	1
†117	GASKET			1	838-1	WASHER	304 STAINLESS	AISI304	1
120-1	BOLT	304 STAINLESS	AISI304	8	838-2	WASHER	304 STAINLESS	AISI304	1
120-2	BOLT	304 STAINLESS	AISI304	4	†849-1	BALL BEARING	—		1
120-3	BOLT	304 STAINLESS	AISI304	6	†849-2	BALL BEARING	—		1
120-4	BOLT	304 STAINLESS	AISI304	3	876	MOTOR PROTECTOR	—		3
120-5	BOLT	304 STAINLESS	AISI304	4	909	LEAKAGE DETECTOR	—		1
120-6	BOLT	304 STAINLESS	AISI304	2	924-1	PACKING	RUBBER (NBR)		1
125	BOLT	304 STAINLESS	AISI304	1	924-2	PACKING	RUBBER (NBR)		1

Motors are purchased as a complete unit

†: Recommended spare parts

**Sectional View**

Project:

Model:

Chk'd:

Date:

**15 to 30HP**

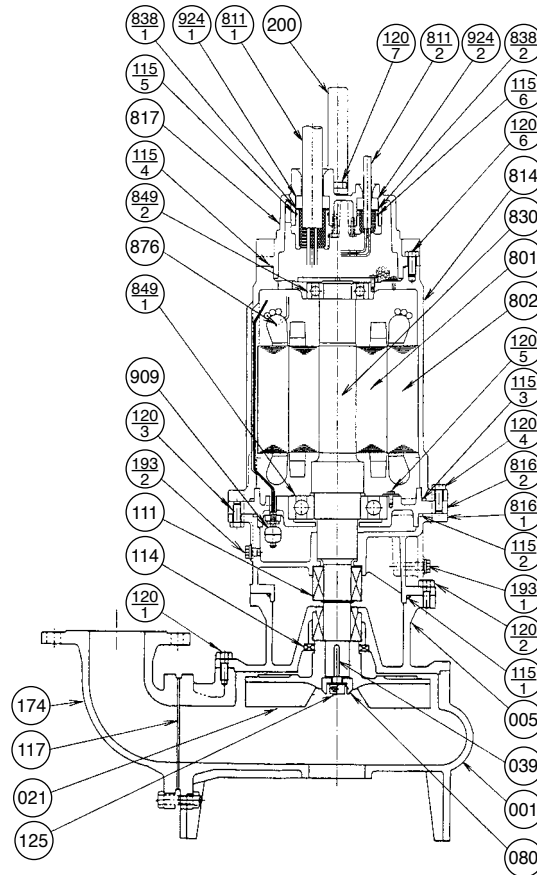

PART NO.	PART NAME	MATERIAL	ASTM, AISI CODE	NO. FOR 1 UNIT	PART NO.	PART NAME	MATERIAL	ASTM, AISI CODE	NO. FOR 1 UNIT
001	CASING	CAST IRON	A48 Class 30	1	174	DISCHARGE ELBOW	CAST IRON	A48 Class 30	1
005	INTERMEDIATE CASING	CAST IRON	A48 Class 30	1	193-1	PLUG	304 STAINLESS	AISI304	1
021	IMPELLER	CAST IRON	A48 Class 30	1	193-2	PLUG	304 STAINLESS	AISI304	1
039	KEY	420 STAINLESS	AISI420	1	200	LIFTING HANGER	STEEL	A283 Grade D	1
080	BUSHING	STEEL	A283 Grade D	1	801	ROTOR	—		1
†111	MECHANICAL SEAL	—		1 SET	802	STATOR	—		1
†114	OIL SEAL	RUBBER (NBR)		1	811-1	POWER CABLE	—		1
†115-1	O-RING	RUBBER (NBR)		1	811-2	CONTROL CABLE	—		1
†115-2	O-RING	RUBBER (NBR)		1	814	MOTOR FRAME	CAST IRON	A48 Class 30	1
†115-3	O-RING	RUBBER (NBR)		1	816-1	BRACKET	CAST IRON	A48 Class 30	1
†115-4	O-RING	RUBBER (NBR)		1	816-2	BRACKET	CAST IRON	A48 Class 30	1
†115-5	O-RING	RUBBER (NBR)		1	817	BRACKET	CAST IRON	A48 Class 30	1
†115-6	O-RING	RUBBER (NBR)		1	830	SHAFT	420J2 STAINLESS	AISI420	1
†117	GASKET			1	838-1	WASHER	304 STAINLESS	AISI304	1
120-1	BOLT	304 STAINLESS	AISI304	8	838-2	WASHER	304 STAINLESS	AISI304	1
120-2	BOLT	304 STAINLESS	AISI304	4	†849-1	BALL BEARING	—		1
120-3	BOLT	304 STAINLESS	AISI304	6	†849-2	BALL BEARING	—		1
120-4	BOLT	304 STAINLESS	AISI304	6	876	MOTOR PROTECTOR	—		3
120-5	BOLT	304 STAINLESS	AISI304	3	909	LEAKAGE DETECTOR	—		1
120-6	BOLT	304 STAINLESS	AISI304	6	924-1	PACKING	RUBBER (NBR)		1
120-7	BOLT	304 STAINLESS	AISI304	2	924-2	PACKING	RUBBER (NBR)		1
125	BOLT	304 STAINLESS	AISI304	1					

Motors are purchased as a complete unit

†: Recommended spare parts

