



**THE RIGHT PUMP FOR
TOUGH JOBS**

**KZE
SERIES**

HIGH CAPACITY HARD METAL SLURRY PUMPS



SIDE DISCHARGE • SUBMERSIBLE • AGITATOR • SLURRY PUMPS

ABRASIVE AND SLURRY APPLICATIONS IN THESE INDUSTRIES AND MORE:

- MINING & COAL MINING
- MINERAL PROCESSING
- SAND & GRAVEL
- STEEL PRODUCTION
- LIME SLURRY, FLY ASH
- HYDRAULIC FRACTURING
- SLURRY TRANSPORT
- DRILLING OPERATIONS -DRILLING MUD

KZE-SERIES

PUMP FEATURES

- **SEALING SYSTEM** - oil cooled and lubricated double mechanical seal design with SiC vs. SiC faces and Buna N elastomers. Seal chamber protected from pumpage by labyrinth rings and lip seal. Seal Minder® - seal leak detection system.
- **BEARING SYSTEM** - Permanently lubricated upper and lower bearings with high temperature grease to extend life. Upper radial bearing is roller bearing design. Lower radial and axial thrust bearing is double row angular contact design.
- **IMPELLER** - Semi-open hard metal slurry type impeller capable of passing 1" solids to accommodate heavy slurry loading.
- **AGITATOR** - Hard metal agitator keeps heavy solids from settling and allows them to be pumped away.
- **PUMP MATERIALS OF CONSTRUCTION** - 28% chrome iron wear parts (volute, impeller, wear plate).
 - 403SS shaft & impeller key
 - 304SS hardware & fasteners
 - Cast iron motor housing
 - High chrome iron agitator

MOTOR FEATURES

- **POWER CABLE** - 50' length standard, GGC power cable with Zener diode for use with ground check controls.
- **SENSOR CABLE** - 50' length for Seal Minder® moisture sensing probe and motor thermal sensors.
- **CABLE ENTRY SEALING SYSTEM** - Compression fitting with Buna N grommet. Individually isolated and potted leads to prevent moisture intrusion and wicking.
- **Class H insulation**
- **1.15 Service Factor**
- **104° F (40°C) Max. Liquid temperature**
- **4 pole motor speed**



KZE-SERIES

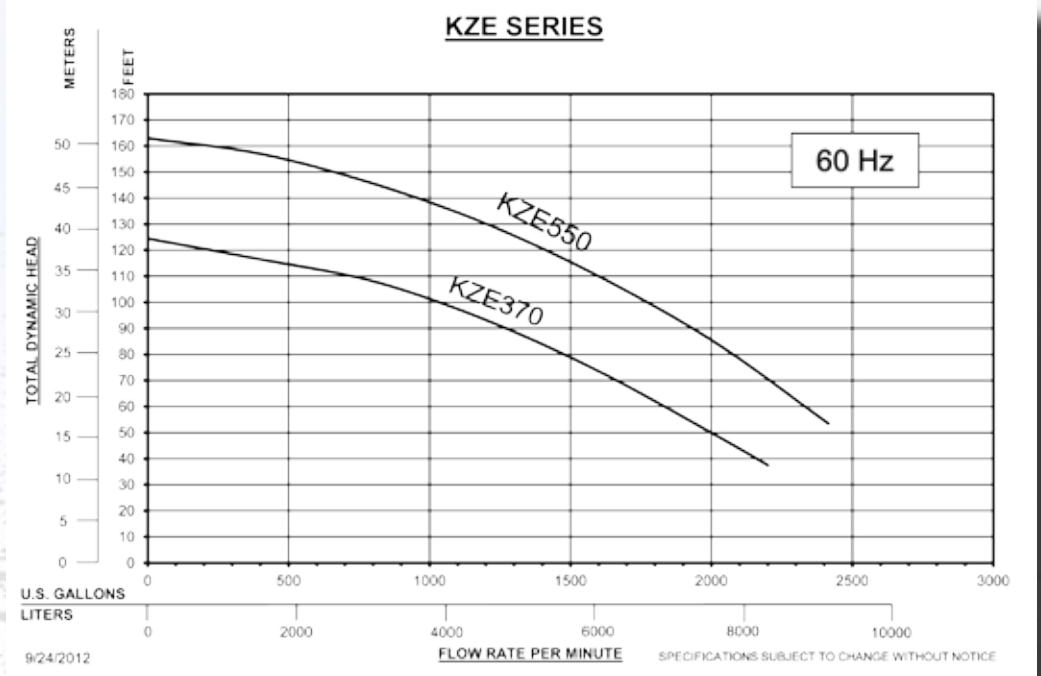

MODEL	DISH SIZE	H.P.	VOLT	PHASE	RPM	RATED AMPS	MAX SOLIDS	MAX HEAD	MAX GPM	HEIGHT	WIDTH	WIDTH	PUMP WEIGHT LBS.	EST. SHIP WEIGHT LBS.
KZE370	8" ANSI	50	460/575	3	1800	62/50	1"	124'	2200	60.8"	27"	27"	1367	1580
KZE550	8" ANSI	75	460/575	3	1800	88/70	1"	163'	2415	65.4"	27"	27"	1874	1955

Custom cable lengths available

KZE - DIMENSIONS

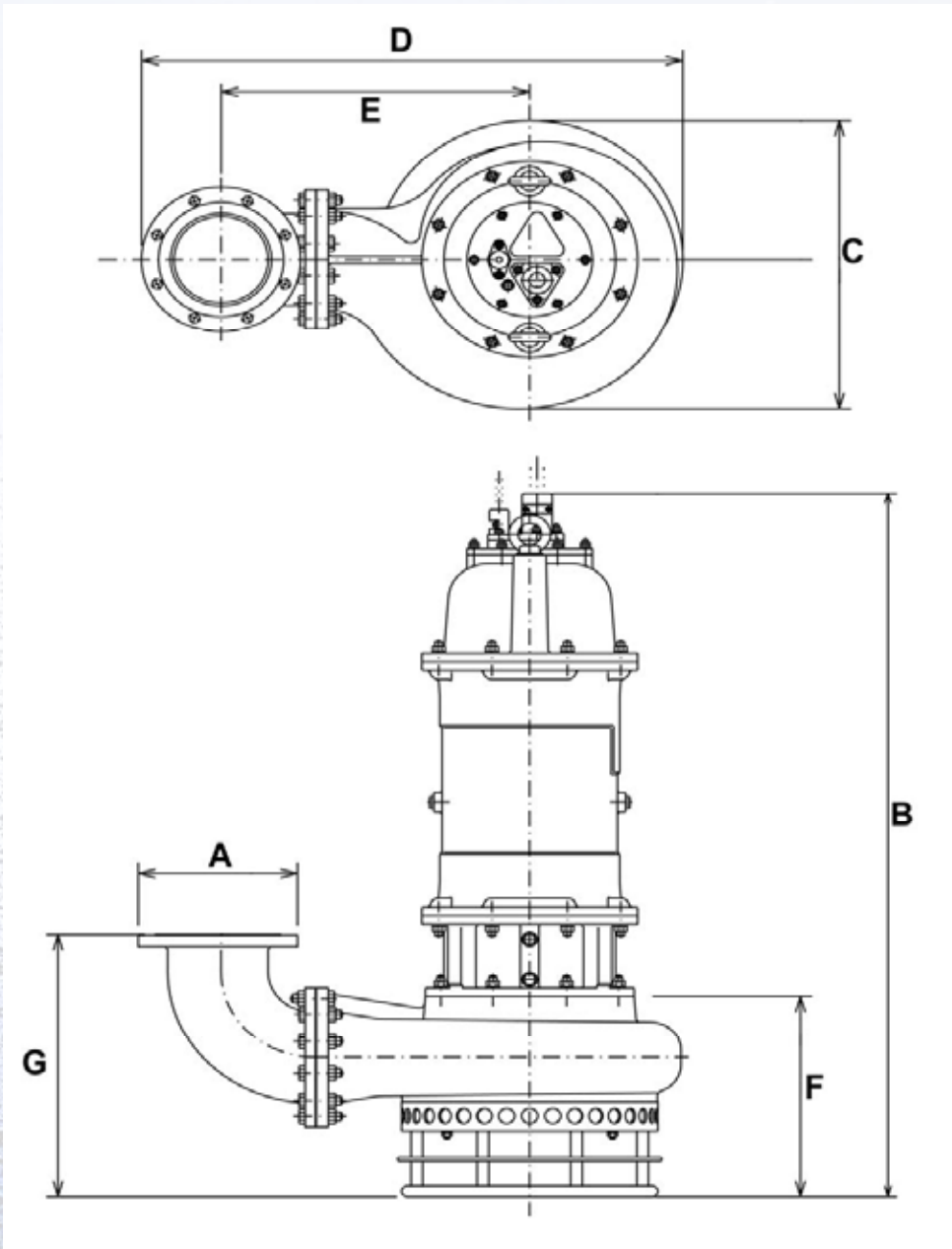

MODEL	A	B	C	D	E	F	G
KZE370	8" ANSI	60.8"	27"	46"	26.2"	19"	24.4"
KZE550	8" ANSI	65.4"	27"	46"	26.2"	19"	24.4"

SPECIFICATION SUBJECT TO CHANGE WITH OUT NOTICE

WARNING: NOT FOR USE IN ANY FLAMMABLE LIQUIDS



123 Spencer Plain Road
P.O. Box 1138
Old Saybrook, CT 06475

Tel: (860)-399-5937
Toll Free: (877)-BJM-PUMP
Fax: (860)-399-7784

Web: www.bjumps.com

Distributor: