

ELECTRICAL SUBMERSIBLE PUMPS WITH SINGLE VANE AND SHREDDER ACTION IMPELLERS FOR MUNICIPAL, INDUSTRIAL AND AGRICULTURAL WASTE-WATER

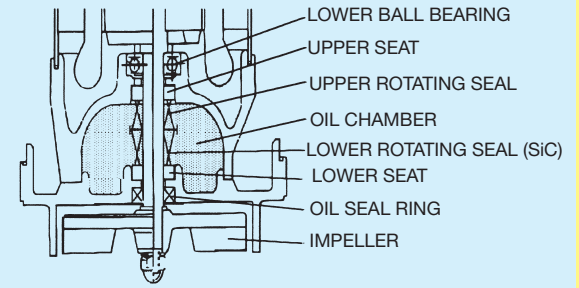

The S and SK models offer high quality and performance for a very modest investment. The pumps are equipped with motor overload protection and dual mechanical seals. The lower seal is made of Silicon Carbide. This assures longer life, less maintenance, and less down time. Each pump is tested at the factory for performance and safety.

Motor casing, impeller shaft and hardware are made of 304 S.S., with other exposed parts made of cast-iron. All pumps feature double mechanical seals (lower; Silicon Carbide) which work in a separate oil chamber. All SK-pumps have built in overload protection against overheating and low or high amperage.



- Triple protection sealing system.
- Double Mechanical Seals in Oil Chamber.
- Oil Seal Ring outside of Oil Chamber.

The Shredder (SK) type pumps leave solids slightly larger than if passed through a grinder pump. The shredding action is caused by using a cutting type impeller with a Tungsten Carbide Tip, against a "spiral" shaped diffuser plate.

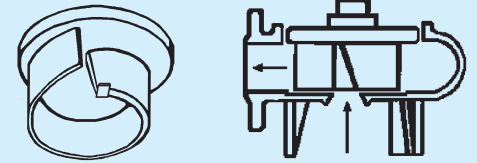

ALL SK MODELS ALSO AVAILABLE IN ALL 316 CAST STAINLESS STEEL

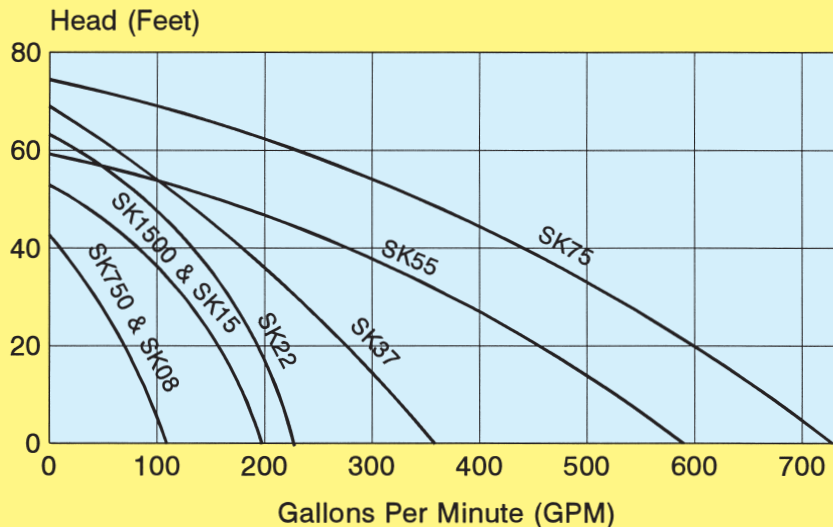

MODEL	H.P.	VOLT	RPM	RATED AMPS	DISCHARGE SIZE	MAX SOLIDS	MAX HEAD	MAX GPM	CABLE	WEIGHT	OVERALL HEIGHT	OVERALL WIDTH
SK750	1	115 or 230	3600	13/7	2 or 3"	3/4"	43	112	33'	61.6	18.9"	11.4"
SK1500	2	230	3600	14	3"	1 1/3"	52	225	50'	77	21.9"	12.2"
SK08	1	230/460	3600	3/1.5	2" or 3"	3/4"	43	112	33'	56.1	16.1"	11.4"
SK15	2	230/460	3600	6/3	3"	1 1/3"	52	225	33'	66	17.7"	11.4"
SK22	3	230/460	3600	9/4.5	3"	1 1/2"	59	255	33'	88	20.5"	12.2"
SK37	5	230/460	1750	14/7	4"	1 1/2"	69	352	33'	96.8	20.8"	12.2"
SK55	7.5	230/460	1750	21/10.5	4"	1 3/4"	59	590	33'	143	27.6"	19.7"
SK75	10	230/460	1750	30/15	4"	1 3/4"	75	730	33'	165	30"	19.7"



SLIDE RAIL FOR S & SK PUMPS

Cut maintenance costs & time with the BJM Slide Rail

Slide rails make routine pump inspections quick and easy. The system virtually eliminates the need for maintenance personnel to climb down into the wet well or sump. Especially beneficial on deep narrow applications.

Guide Rail Basemount w/slide holders

Model Number	Product Description
SR50	2" NPT Slide rail base w/top; fits models S & SK-750, 08, 1500, 15.
SR80	3" NPT Slide rail base w/top; fits models S & SK-750, 08, 1500, 15, 22, 37.
SR100	4" NPT Slide rail base w/top; fits models S & SK-750, 08, 1500, 15, 22, 37, 55, 75.
SR150	6" NPT Slide rail base w/top; fits models S & SK-55, 75.

ALL S AND SK MODELS, INCLUDING SLIDERAIL SYSTEMS, AVAILABLE IN CAST 316 STAINLESS STEEL!

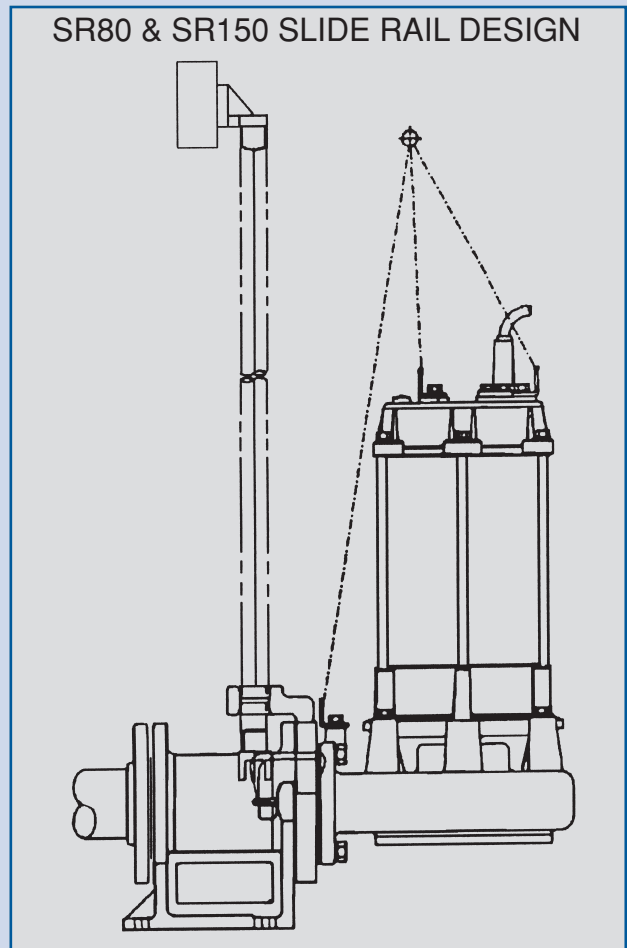
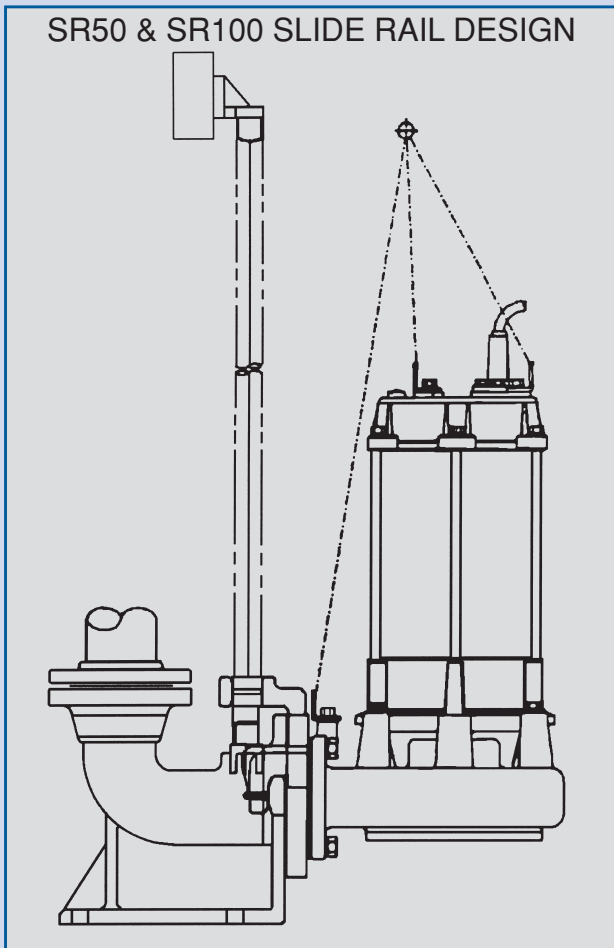

OUTSTANDING FEATURES FOR ALL BJM PUMPS: To ensure longer life, less maintenance and less downtime, BJM pumps (0.5 H.P. and up) feature double mechanical seals in a separate oil chamber. In addition, an oil seal ring has been installed under the oil chamber. All BJM pumps are equipped with a thermal breaker. Pumps, 1 HP and up, have overload protection against overheating and low or high amperage. Level controls and level control systems are available.

123 Spencer Plains Road
P.O. Box 1138
Old Saybrook, CT 06475
Tel. (860) 399-5937
(800) 442-BJMC
Fax. (860) 399-7784

Distributor: