

VERTIFLO

Series 1300 CLOSE-COUPLED END SUCTION PUMPS

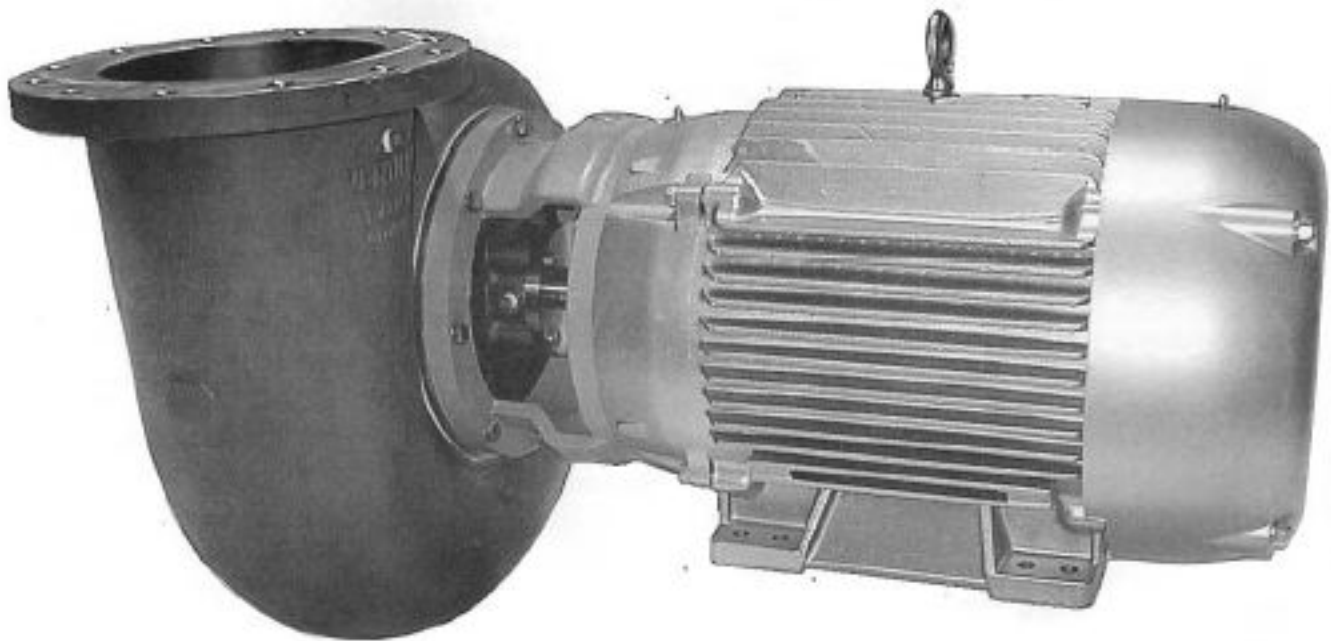

**Installation, Operation
& Service Instructions**

1. INSTALLATION INSTRUCTIONS

VERTIFLO Series 1300 horizontal close-coupled pumps are completely assembled, carefully adjusted, and pre-lubricated at the factory before shipment.

A. Carefully set pump at the required location. Do not use the motor eyebolt to lift the entire pump. Check for full contact of the motor base to the mounting surface. Check to insure pump casing is not contacting any structure as motor feet bolts are tightened.

B. Connect the system piping to the suction and discharge flanges of the pump case. A check valve and gate valve should be installed in the discharge piping and a gate valve in the suction piping. An elbow in the suction piping should not be closer to the pump than the equivalent of (5) five times the suction pipe diameter.

Note: All piping is to be independently supported. The pump cannot tolerate piping strain.

C. Connect power to motor per wiring diagram on motor based on your supply voltage. Follow all state and local wiring codes.

D. Check motor starter and overload protection to insure they are properly rated for required voltage and amperage.

E. Check for free rotation by turning exposed shaft by hand. If any dragging or binding is evident, re-check for piping strain. If still binding, see **section 2** Impeller adjustment.

F. Open suction line valve to allow fluid to fill pump. Close discharge valve. Jog motor under power momentarily to confirm shaft is turning clockwise viewing from motor end. If rotation is incorrect, wiring must be modified to change rotation.

G. Once rotation is correct, start pump with suction valve open and discharge closed. Slowly open discharge valve until desired flow is achieved. If pump runs smoothly until valve is near or fully opened, then becomes noisy or vibrates, a partially closed discharge valve may be required to keep the pump operating on its' curve.

2. IMPELLER ADJUSTMENT

1300 Series pumps are adjusted at the factory with conservative clearances due to hazards encountered during shipment and less than perfect mounting and piping conditions. If after installation, the impeller drags or binds in the casing, and all other causes have been addressed, re-adjustment may be necessary. Impeller adjustment is accomplished by adding or removing shims between the shaft sleeve and the impeller. On rare occasion, an extra case gasket may be required. Ideally, there should be just enough clearance to prevent contact between the suction face of the impeller vanes and the internal suction face of the pump case. Due to hydraulic and physical variables, we suggest starting at .025" to .035" clearance and adjusting as required for your particular conditions. This dimension may need to be greater as the size of the pump increases.

A. Disconnect power to motor. Remove motor base bolts and (8) case bolts. Remove motor and rotating assembly from pump case. (If not yet connected to piping system, simply remove casing)

B. With a depth gage, measure the depth of the case from the case gasket surface to the internal suction face of the case. Add .060" for the gasket to this dimension and record.

C. With a depth gage, measure the distance from the case gasket surface of the seal head/case cover to the suction face of the impeller vanes. Remove impeller and add or subtract shims as required to make this dimension .025" to .035" shorter than the case and gasket depth.

D. Replace casing and turn shaft by hand to ensure free rotation.

Caution: During re-assembly of casing to pump, tighten eight ½ -13 hex head bolts slowly and evenly. As you tighten, constantly check for free shaft rotation. If shaft & impeller seizes before all bolts are tightened, remove case and re-check measurements. Reduction of shim thickness may be necessary to provide clearance between suction face of case and face of impeller vanes. Damage to pump or motor may occur if casing is installed without clearance.

3. PUMP DISASSEMBLY

The 1300 series pump is a back pull-out design that can be serviced without removing the pump casing from the piping system.

A. Disconnect all electrical wiring from motor.

B. Close all fluid valves to and from the pump.

C. Drain fluid from pump through the case drain plug.

D. Remove motor feet bolts.

E. Remove eight pump case bolts (55) and slide motor and rotating assemble out of case far enough to insert two ½ -13 hex nuts 180 degrees apart between the case and seal head. Re-insert two case bolts through the motor adaptor (1) and seal head flange (53) into the nuts and tighten. This will hold the seal head and seal assembly in position during disassembly.

F. Remove RH threaded impeller bolt (5) with "O" ring (7), washer (4), & gasket (6).

G. Place two pry bars 180 degrees apart between the back shroud of the impeller (50) and the seal head (53) and pry the impeller off the shaft.

H. Slide the mechanical seal spacer sleeve (27), washer(46), and spring (45) off the shaft.

I. Remove impeller key (3) and shims (8).

4. MECHANICAL SEAL DISASSEMBLY

Follow directions 3.A through 3.I. If further disassembly, seal inspection, or replacement is required, continue as follows:

A. Remove four bolts or nuts (10) from seal gland (25). Carefully slide back from seal head (53) and let it rest on shaft.

B. Remove the two ½ -13 bolts and nuts (55) installed during removal from casing.

C. The seal head (53) can now be removed from the motor adaptor (1).

D. Carefully slide the exposed rotary seal (44) off the shaft sleeve (2). Handle with care and avoid any contact with the seal face. Keep it protected by wrapping in a soft media and setting it in a safe place.

(**Note:** Shaft sleeve may slide off the shaft when attempting to remove the rotary seal element from the sleeve. If this happens, the rotary seal can be pushed off afterwards.)

E. Carefully slide the seal gland (25) off the motor shaft. The stationary seal face (43) must be protected from any contact except with clean, dry, non-marring surfaces.

F. Press out the stationary seat and cup (43) from the motor side of the gland.

G. Remove shaft sleeve (2)

H. Remove shaft slinger (9).

I. Unbolt and remove motor adaptor (1).

5. PUMP ASSEMBLY

The following conditions must be maintained for a successful assembly re-using original parts from a previous service.

All parts must be in new or like new condition. They must be clean and free of any nicks, pitting, or wear patterns on their locating or sealing surfaces. The shaft run out cannot exceed .004" T.I.R. at any point.

For seal installation, use a compatible lubricant sparingly on the shaft sleeve, inner elastomeric boot of the rotary seal, seal gland bore and outside of stationary cup. Use no more than absolutely necessary! Do not allow lubricant to contact sealing faces! Remove any excess lubricant after installation.

A new mechanical seal and gaskets are always recommended.

A. Attach motor adaptor (1) to motor with openings to each side.

B. Slide shaft sleeve (2) over motor shaft with keyed end towards impeller.

C. Install shaft slinger (9). Position near the motor end opening of the support (1).

D. Cover sealing face of stationary (43) with a smooth, clean piece of cardboard or cloth. Carefully press stationary seal ring and cup (43) into the seal gland (25) using your thumbs 180 degrees apart. **Caution:** Breakage can occur with excessive or uneven pressure during this operation.

E. Carefully slide gland (25) with stationary (43) installed over shaft with seal face towards pump end. Repeat with gland gasket (56).

F. With sleeve lightly lubricated, slide rotary part of seal (44) over shaft with sealing face toward motor. Position with one inch of shaft sleeve protruding from seal.

G. Mount seal head (53) to motor adaptor with pipe plug hole to the side. Use caution to prevent contact with rotary and stationary seal parts. Use two ½ -13 bolts (55) and nuts 180 degrees apart to secure to bracket (1).

H. Bolt seal gland (25) to seal head with gasket (56) in between.

I. From impeller end of seal head, push rotary seal (44) toward gland and motor until it seats against stationary seal (43).

J. Insert seal spring (45), washer (46), and .030" orange shim (8). Insert impeller key (3) in key way of shaft and push into the key way of sleeve. Key should not extend beyond the end of the shaft. Trim end until flush if required.

K. Slide seal spacer sleeve over shaft. It will extend beyond the end of the sleeve. This is required to allow spring compression when the impeller is installed.

Note: If impeller clearance is unknown, you may skip spacer installation from "5-K" and washer gasket and "o"ring from "5-L" until final shims are installed.

L. Install impeller (50), washer gasket (6), "O"ring (7), impeller bolt (5) and tighten.

M. Follow directions for impeller clearance adjustment in **Section 2** to determine proper shim thickness. Remove impeller and correct shim thickness. Repeat 5-K & 5-L.

Note: Once shims are correct, spacer sleeve (27), washer gasket (6), and O-ring (7) must be installed before final assembly if left out per notes in "5-K".

N. Remove the two ½ -13 bolts and nuts Securing seal head (53) to motor adaptor bracket (1). Place case gasket (54) in position and bolt rotating assembly to casing.

Note: If casing is still connected to piping system, **DO NOT FORCE ROTATING ASSEMBLY INTO CASING.** Casing may have shifted due to pipe strain. Casing and piping must be re-aligned with rotating assembly if this condition exists.

O. Replace bolts in motor feet. Make sure Motor feet are seated evenly on base. Replace or add required shims to eliminate any stress when motor feet bolts are tightened.

P. Replace case and pipe drains.

Q. Check for free shaft rotation.

R. Connect power to motor.

S. Refer to **Section 1** installation instructions for start up.

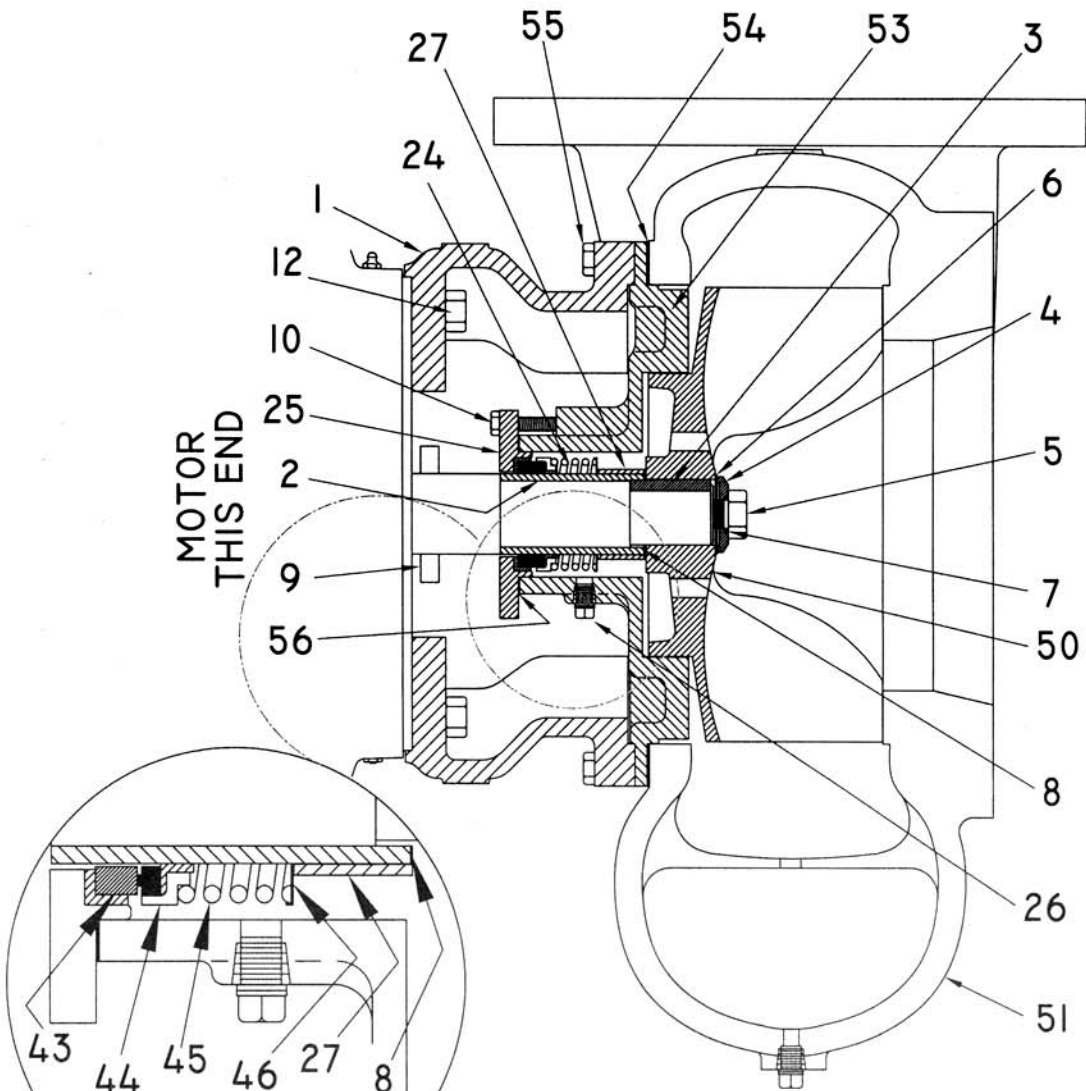

MOTOR
THIS END

- | | | | |
|----|-------------------|-----|---------------------|
| 1 | MOTOR ADAPTOR | 24* | MECHANICAL SEAL |
| 2* | SHAFT SLEEVE | 25 | SHAFT SLINGER |
| 3 | IMPELLER KEY | 26 | SEAL HEAD PIPE PLUG |
| 4 | IMPELLER WASHER | 27 | SEAL SPACER SLEEVE |
| 5 | IMPELLER BOLT | 43 | STATIONARY SEAL |
| 6* | IMP WASHER GASKET | 44 | ROTARY SEAL |
| 7* | IMP WASHER O RING | 45 | SEAL SPRING |
| 8* | IMPELLER SHIMS | 46 | SPRING WASHER |
| 9 | SLINGER | 50 | IMPELLER |
| 10 | SEAL GLAND BOLT | 51 | VOLUTE CASING |
| 12 | MOTOR BOLT | 53 | SEAL HEAD |
| | | 54* | CASE GASKET |
| | | 55 | CASE BOLT |

PUMP SERIAL NUMBER REQ'D
WHEN ORDERING BY ITEM #

*Recommended Spare Parts



VERTIFLO PUMP COMPANY
7807 REDSKY DRIVE
CINCINNATI, OHIO 45249
513-530-0888 Fax: 513-530-0893