

Series 700

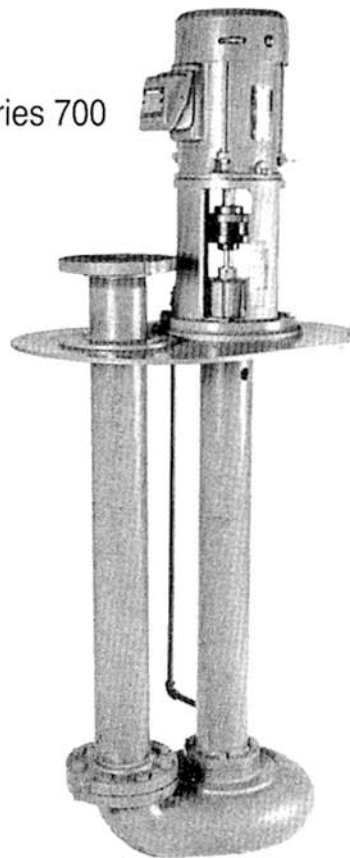

Sewage

Series 800

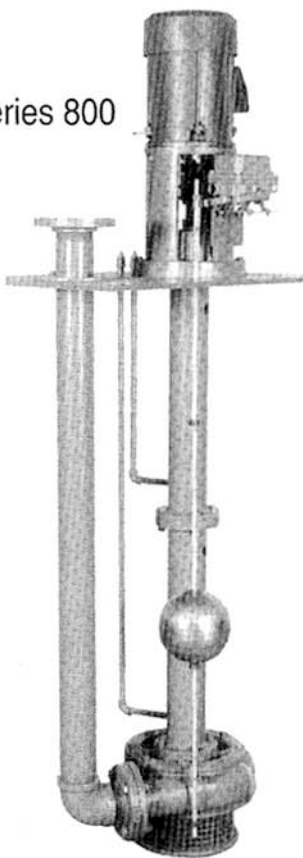

Sump

Series 900



Vortex

IMPORTANT Safety Precautions

In order to minimize the risk of accidents in connection with the service and installation work, the following rules should be followed:

1. Never work alone. Use a lifting harness, safety line, and a respirator as required. Do not ignore the risk of drowning!
2. Make sure that there is sufficient oxygen and that there are no poisonous gases present.
3. Check the explosion risk before welding or using electric hand tools.
4. Do not ignore health hazards. Observe strict cleanliness.
5. Bear in mind the risk of electrical accidents.
6. Make sure that the lifting equipment is in good condition.
7. Provide a suitable barrier around the work area, for example a guard rail.
8. Make sure you have a clear path of retreat!
9. Use safety helmet, safety goggles and protective shoes.
10. All personnel who work with sewage systems shall be vaccinated against diseases that can occur.

Follow all other health and safety rules and local codes and ordinances.

HANDLING INSTRUCTIONS

Do **NOT** put any strain on column pipe and shaft assembly. Lifting equipment should be attached to motor support bracket or cover plate. Avoid bending of column pipe and shaft assembly.

I. INSTALLATION INSTRUCTIONS

VERTIFLO's Vertical Wet Pumps, Series 700 (sewage), 800 (sump) and 900 (vortex) are completely assembled, carefully adjusted and prelubricated at the factory before shipment.

1. Remove banding straps and caps screws holding pump to skid.
2. Remove coupling guard, if supplied, and turn pump by hand, checking for free rotation.
3. If motor is not mounted, remove motor coupling half (12A) and install on motor shaft. Do not tighten set screws until after motor installation.
4. If float switch is supplied, proceed as follows:

Note: Float collars (52) use a stainless set screw which is very effective at holding collar in position with minimum torque. Overtightening will strip threads in collar.

Assemble float rod (51) and collars (52) as shown in figure (1). (If other than Square D switch is used, see their instructions for assembly.)

Position and set screw float collar (54D) approximately 4" below pump shut off level. Position float collar (54C) approximately 3" above pump startup level.

Position (54A) and (B) on each side of switch arm with sufficient space to allow free movement of arm. (Approximately 1/2" each). Manually slide float ball through its cycle to assure unobstructed movement of float rod, collars and float.

After installation of pump in sump per following these instructions, the compensation spring in switch can be adjusted as follows:

With sump filled to midway point of start and shut off (float ball suspended by fluid) raise switch lever to the upward position. Adjust the tension so lever is maintained in this position. Place lever arm in the downward position. Adjust tension so that lever remains in this position. Recheck both positions.

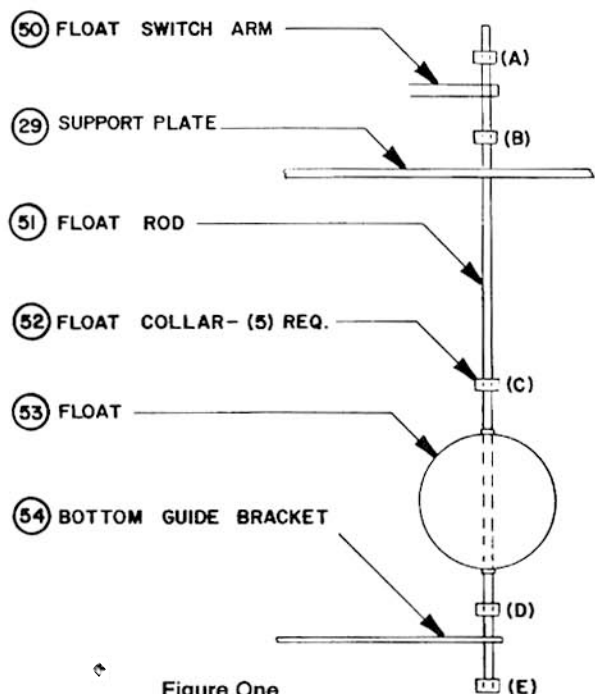

5. If supplied with a **highwater alarm**, install one of the 1/2"x12" pipes in the tank side of the 1/2" pipe coupling welded to the cover plate. If supplied with a **mercury switch**, install switch before inserting into sump.

6. Lift pump by the support plate or motor support; carefully lower unit into sump. Check to insure that support plate is setting flat on top of sump or support ring. Secure plate by bolting. Check again for **free rotation**.

7. Connect discharge piping. If unit is supplied with a flange, tighten to proper location. Factory **flanges are hand tight only. No piping strain is allowed on the pump assembly.** Check again for free rotation.

8. If motor has been shipped separately, and pump has a one piece shaft, (12' pump length and shorter) mount motor-adjusting coupling per manufacturer's recommendation. Connect power lines to motor leads as shown on the wiring diagram of the motor for specific line voltage used. Check, and be sure starter and overload protection is proper for specific voltage and for the amperage rating. Follow all state and local wiring codes.

If the pump is longer than 12' (supplied with a two piece shaft), **reverse rotation will damage pump**. If this is the case, then rotation must be checked with the rubber insert out of the coupling. Check again for free rotation.

9. Wire float switch according to instructions supplied with float switch. If supplied with a high water alarm, install the remaining 1/2" pipe in top of pipe coupling, with high water alarm screwed on top. Wire to appropriate device or panel. All wiring should be done by a qualified electrician and according to all codes and regulations.

10. Jog motor quickly to check for proper rotation. A shaft rotational arrow is marked on the motor support, with rotation clockwise when looking down on the motor.

11. Install coupling guard if supplied.

12. Close discharge gate valve. Start unit. Open valve slowly to desired flow and head. Pump should run smoothly, free of vibration. If rubbing is felt, check for piping strain and check **impeller adjustment, section II.**

IIA. IMPELLER ADJUSTMENT FOR 700 AND 800 SERIES PUMPS.

1. Disconnect power to motor and all controls.

2. Remove coupling guard if supplied.

3. Remove set screw (15) from adjusting nut (14).

4. Loosen adjusting nut (14) allowing shaft (21) to drop. If shaft does not drop, lightly tap top of adjusting nut (careful not to damage threads). Use the coupling to turn shaft to assure impeller is against the suction head (32) or case (31). Resistance to turning will be felt.

5. Tighten adjusting nut (14) until rotation is free. On cast iron units, turn adjusting nut one additional flat for proper running clearance. On 316SS or alloy units, turn adjusting nut 2 additional flats.

6. Align one of the set screw holes in adjusting nut (14) with keyway in shaft (21).

7. Insert set screw (15) into adjusting nut (14) and tighten.

Do not tighten against the threads of the shaft.

8. Check for free rotation.

9. Reinstall coupling guard.

Series 700

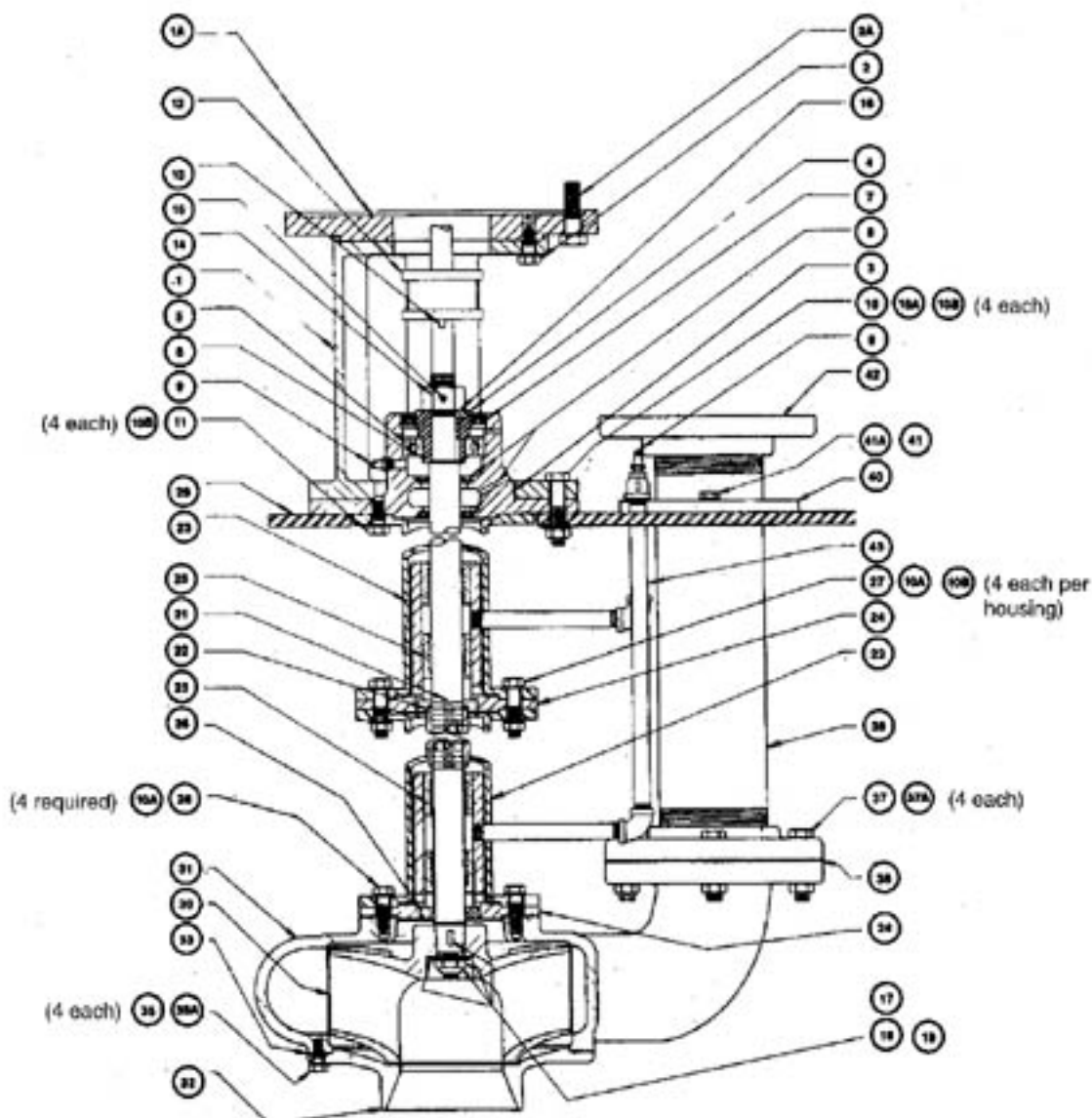

ITEM NO.	DESCRIPTION	ITEM NO.	DESCRIPTION	ITEM NO.	DESCRIPTION
1	MOTOR SUPPORT	11	CAP SCREW	27	CAPSCREW
1A	MOTOR ADAPTOR	12	COUPLING	28	CAPSCREW
2	CAPSCREW	13	SHAFT KEY	29	SUPPORT PLATE
2A	MOTOR CAPSCREW	14	ADJUSTING NUT	30	IMPELLER
3	THRUST BEARING HOUSING	15	SET SCREW	31	CASING
4	BEARING ADAPTOR	16	GIB KEY	32	SUCTION HEAD
*5	THRUST BEARING	17	IMPELLER KEY	35	CAPSCREW
6	SNAP RING	18	IMPELLER NUT	35A	LOCKWASHER
*7	TOP LIP SEAL	19	IMPELLER WASHER	37	CAPSCREW
*8	BOTTOM LIP SEAL	21	SHAFT	37A	HEX NUT
9	GREASE FITTING	22	SHAFT COUPLING	38	GASKET
10	CAPSCREW	23	COLUMN	39	DISCHARGE PIPE
10A	LOCKWASHER	24	BEARING HOUSING	40	BACK-UP RING
10B	HEX NUT	*25	LINE SHAFT BEARING BUSHING	41	CAPSCREW
		*26	CHOKER RING	41A	LOCKWASHER
				42	FLANGE (OPTIONAL)
				43	LUBE LINE

*Recommended Spare Parts

Series 800

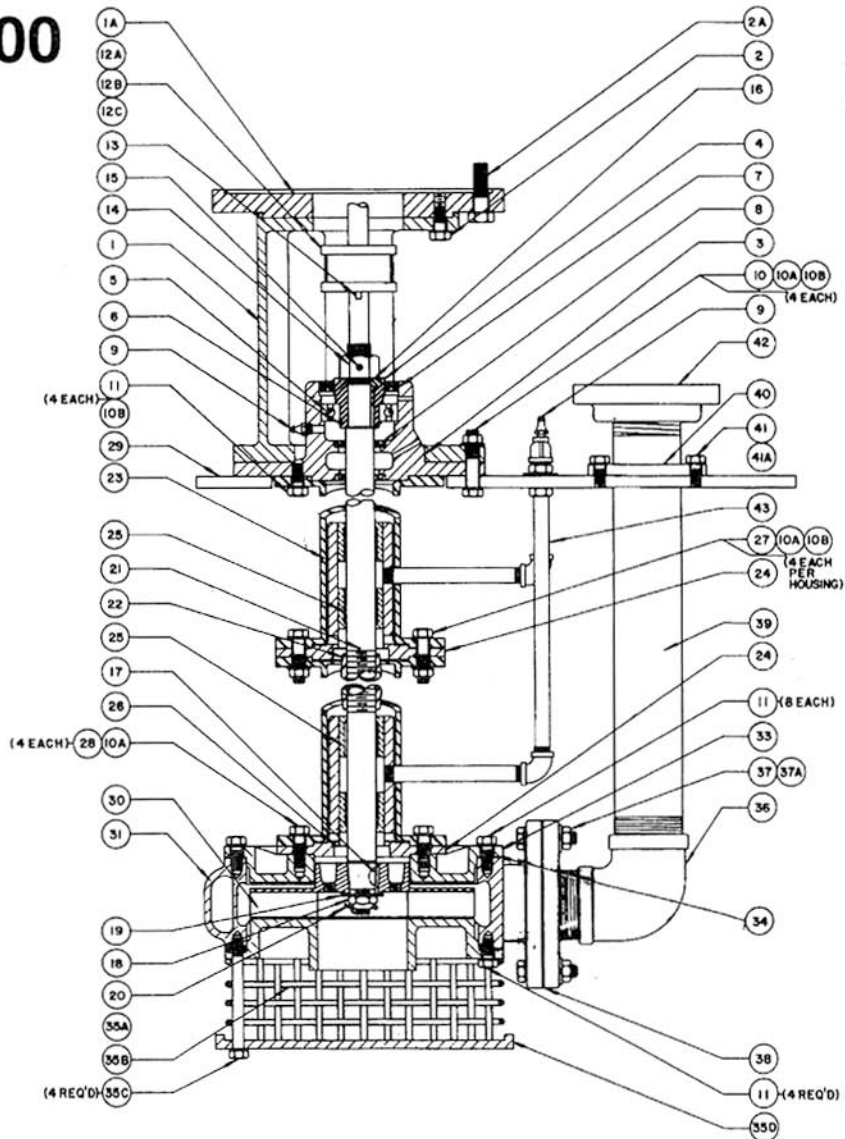

ITEM NO. DESCRIPTION

1	MOTOR SUPPORT	15	SET SCREW	33	CASE ADAPTOR
1A	MOTOR ADAPTOR	16	GIB KEY	34	GASKET
2	CAPSCREW	17	IMPELLER KEY	35	STRAINER ASSEMBLY
2A	MOTOR CAPSCREW	18	IMPELLER NUT	35A	TOP PLATE**
3	THRUST BEARING HOUSING	19	IMPELLER WASHER	35B	BASKET
4	BEARING ADAPTOR	20	COTTER PIN	35C	STUD
*5	THRUST BEARING	21	SHAFT	35D	BOTTOM PLATE
6	SNAP RING	22	SHAFT COUPLING	35E	STUD NUT
**7	TOP LIP SEAL	23	COLUMN	36	DISCHARGE ELBOW
*8	BOTTOM LIP SEAL	24	BEARING HOUSING	37	CAPSCREW
9	GREASE FITTING	*25	LINE SHAFT BEARING BUSHING	37A	HEX NUT
10	CAPSCREW	*26	CHOKER RING	38	GASKET
10A	LOCKWASHER	27	CAPSCREW	39	DISCHARGE PIPE
10B	HEX NUT	28	CAPSCREW	40	BACK-UP RING
11	CAP SCREW	29	SUPPORT PLATE	41	CAPSCREW
12	COUPLING	30	IMPELLER	41A	LOCKWASHER
13	SHAFT KEY	31	CASING	42	FLANGE (OPTIONAL)
14	ADJUSTING NUT			43	LUBE LINE

* Recommended spare parts

** Not shown on drawing. Used only on following pumps.

1 1/2 x 1 x 8	3 x 2 x 8	4 x 3 x 8	will be similar to,
2 x 1 1/2 x 8	3 x 2 1/2 x 7	5 x 4 x 8	and opposite, bottom plate (35D)

Series 900

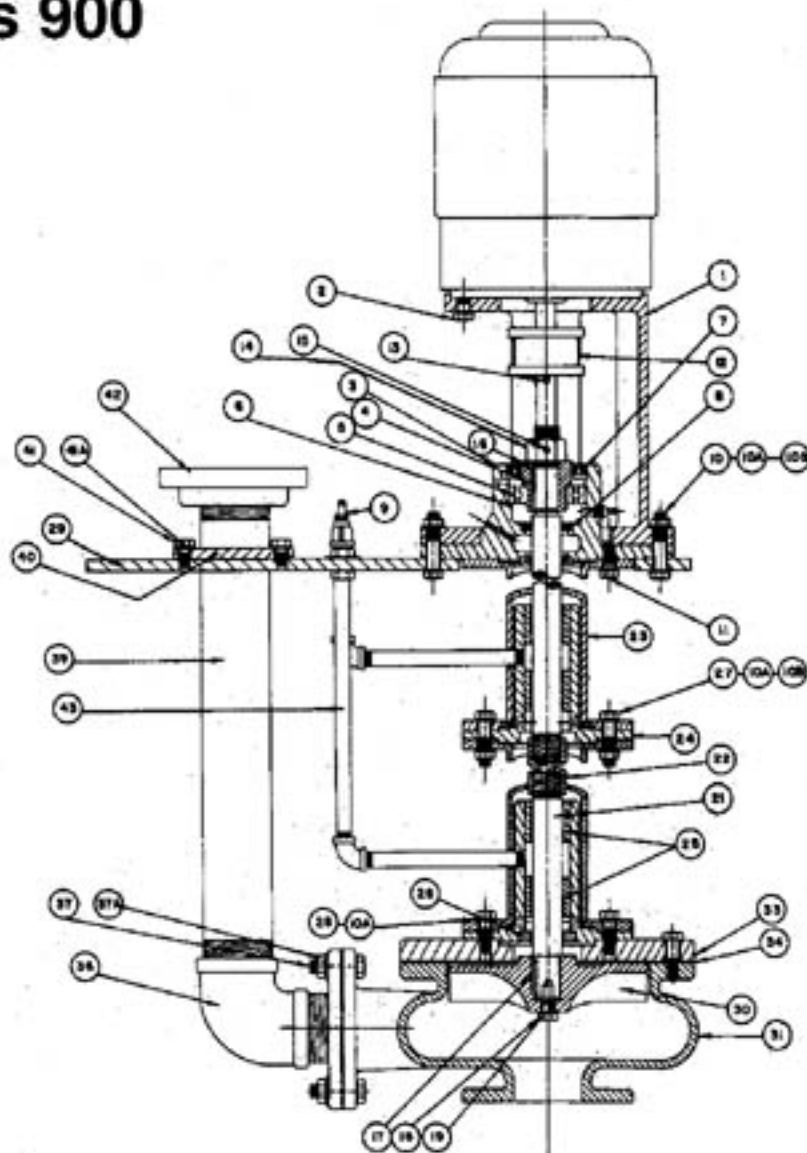

ITEM NO.	DESCRIPTION				
1	MOTOR SUPPORT	11	CAP SCREW	27	CAPSCREW
1A	MOTOR ADAPTOR	12	COUPLING	28	CAPSCREW
2	CAPSCREW	13	SHAFT KEY	29	SUPPORT PLATE
3	THRUST BEARING HOUSING	14	ADJUSTING NUT	30	IMPELLER
4	BEARING ADAPTOR	15	SET SCREW	31	CASING
*5	THRUST BEARING	16	GIB KEY	33	CASE ADAPTOR
6	SNAP RING	17	IMPELLER KEY	34	GASKET
*7	TOP LIP SEAL	18	IMPELLER NUT	36	DISCHARGE ELBOW
*8	BOTTOM LIP SEAL	19	IMPELLER WASHER	37	CAPSCREW
9	GREASE FITTING	21	SHAFT	37A	HEX NUT
10	CAPSCREW	22	SHAFT COUPLING	39	DISCHARGE PIPE
10A	LOCKWASHER	23	COLUMN	40	BACK-UP RING
10B	HEX NUT	24	BEARING HOUSING	41	CAPSCREW
		*25	LINE SHAFT BEARING BUSHING	41A	LOCKWASHER
		*26	CHOKER RING	42	FLANGE (OPTIONAL)
				43	LUBE LINE

*Recommended Spare Parts

IIB. IMPELLER ADJUSTMENT FOR 900 SERIES

1. Follow IIA instructions for 1 through 3.
2. Tighten adjusting nut (14) raising shaft (21) until free rotation stops. (Indication impeller has contacted case adaptor (33).)
3. Loosen adjusting nut (14) until rotation is free, then turn the adjusting nut 2 additional flats.
4. Align one on the set screw holes in the adjusting nut (14) with the keyway in shaft.
5. Insert set screw (15) into adjusting nut (14) and tighten. **Do not** tighten against threads of shaft.
6. Check for free rotation.
7. Reinstall coupling guard.

III. LUBRICATION

1. The pump thrust bearing (5) should be greased every two or three months depending on the type of service.
A lithium based grease with rust inhibiting properties, such as **Shell Alvania #2** or equal should be used.
2. **Line shaft bearing bushings (25).**
A. Bronze or cast iron bushings should be greased every 8 hours of operation with a water resistant grease such as **Lubri-Plate 142**.
B. Carbon or teflon bushings—applications with little or no abrasives, lubrication is provided by the product pumped with no external lubrication required. If abrasive concentration is medium, external lubrication is required; either clean water or a liquid compatible with the product being pumped. If abrasive concentration is heavy, a solenoid valve should be supplied and wired to open 15 to 20 seconds before pump operation to initially cleanse the bushings.
C. Rubber bushings **must** be provided with an external clean water flush and solenoid valve.
3. Motor bearings should be lubricated in accordance with the manufacturer's recommendations.

IV. INSPECTION AND REPAIR OF LIQUID ENDS

1. Close discharge valve.
2. Turn off all power to motor and controls and disconnect wiring. If motor is large and cumbersome, it may be easier to remove at this time.
3. Disconnect discharge piping.
4. Remove foundation bolts.
5. Pump should be free to remove from sump. Lift at motor support and/or discharge pipe. Place horizontally on ground or floor. **Do not lift using column pipe as a lift point.**
6. If pump is contaminated by sewage or chemicals, flush with water or a neutralizer until safe to handle.

Note: Match center-punch all parts to be removed for correct assembly.

700 SERIES

7. Remove suction head (32).
8. Hold the pump coupling half with a strap wrench and loosen impeller nut. **Do not remove—must remain at end of threads to protect while puller is used.**
9. Impeller (30) must be removed before casing (31) can be removed. Make a pulling bar as illustrated in fig. 4. **Loosen Impeller.**
10. Remove in order: impeller puller, impeller nut (18), impeller washer (19), impeller (30), and impeller key (17).
11. Remove capscrews (11) from casing flange. Remove capscrews (28) from the bottom column flange.
12. Remove casing (31).

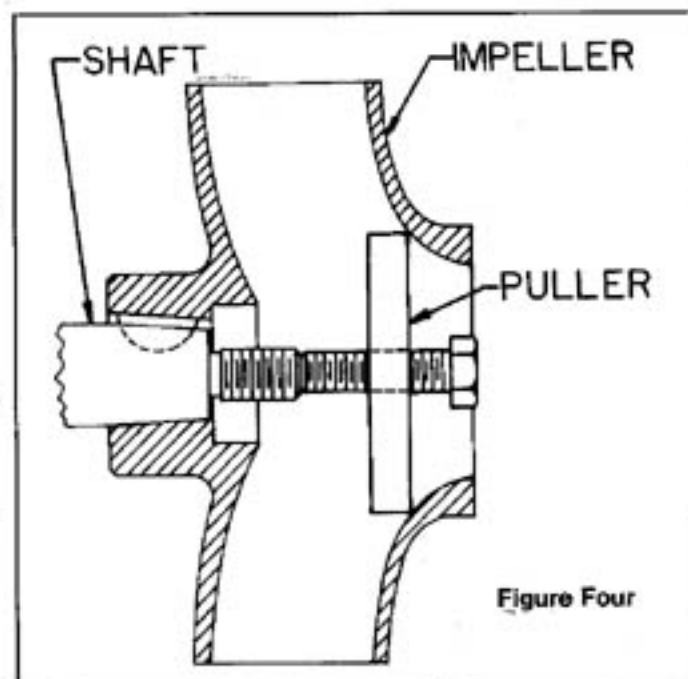

Figure Four

800 SERIES

7. Remove capscrews (11) from casing flange.
8. Remove capscrews at case adaptor (33) and discharge flange capscrews. Remove casing (31). Remove cotter pin. On pump size 2 x 1 1/2 x 12 remove suction head, impeller and case.
9. Hold the pump coupling half with a strap wrench and remove impeller nut (18) or capscrew. Remove impeller washer (19).
- 10A. All impellers, sizes from 1 1/2 x 1 x 8 through 6x6x10A, including the 2x1 1/2 x 12 are secured to the shaft by a taper. To remove these impellers, use 3 fully threaded capscrews 1/2x13NCx2 1/2" as jackscrews in the threaded holes in the impeller shroud to force impeller (30) off of the tapered shaft (21).
- 10B. Sizes 4x4x12 through 8x8x12 are secured to the shaft with a straight bore. Place 2 pry bars between case adaptor (33) and impeller (30) and pry impeller off shaft (21).
11. Remove impeller key (17).

900 SERIES

7. Remove capscrews from casing flange.
8. Remove capscrews at case adaptor and remove casing. 9. Hold pump half coupling with a strap wrench and remove impeller screw. Remove impeller.
10. Vortex impellers are secured to the shaft with straight bores. Place 2 pry bars between case adaptor (33) and impeller (30) and force impeller from shaft (21).
11. Remove impeller key (17).

V. INSPECTION AND REPLACEMENT OF LINESHAFT BEARING BUSHINGS

Note: Match—mark all parts to be removed.

1. Remove strainer assembly and/or casing as described above.
2. Disconnect grease line(s) (43).
3. Unscrew four (4) capscrews (28) holding the casing adaptor (33) and bottom column pipe flange (23). The casing adaptor and bottom bearing housing can now be removed from the column pipe (23).
4. To remove the choker ring (26) and bearing bushings (25), make up a piece of tubing of proper size and press the bushing (23) and choker ring (26) out through the bottom of the bearing housing (24). Be sure to note orientation of these two parts in the housing.
5. To remove intermediate bearing housing (24) and bearing bushings (25), remove four (4) flange bolts, nuts and washers (27, 10A, 10B). Then slide column carefully off over shaft. Follow by sliding intermediate bearing housing (24) off shaft. Note position of bushings before removing and follow same instructions as described in 4.
6. If 2 piece shaft, separation is required before lineshaft bearings can be removed.

VI. INSTALLING NEW BEARING BUSHINGS

Examine bearing housing and bushings for wear and deterioration. If housing is damaged, order a bearing assembly from your local distributor which would be factory assembled. If only bearing bushings show wear replace as follows:

1. Cast Iron, Bronze or Carbon Bearing Bushings

All bearing bushings of this style are a press fit and contain two bushings (25) per housing except the 724-H, 824-H and 924-H bottom bearing assemblies, which contain three bushings.

A. Place bearing housing (24) in a vertical position with flange up and nose down. Housing must be supported by machined surface of flange. A piece of 5" pipe with ends cut square best serves the purpose. Staggering lube grooves in both bearings is preferred. Carbon bushings can be inserted in either end due to continuous lubricating grooves. Bronze and cast iron bushings must be installed as follows: Insert first bushing with closed groove end down. Press through housing until flush with nose end of housing. Press second bushing with closed end up into housing until it clears vent holes in side of housing. If required, press choker ring into housing until it stops. It should be flush with machined surface. Make

sure lube hole is clear. Improper assembly is at fault if hole is covered. Pump failure may result.

2. Teflon Bushings

- A. Place bearing housing (24) in a vertical position with flange up.
- B. Check visually which end to insert first to assure alignment of groove to lube hole, With bushing flush with nose end of housing, press bushing into housing until outside groove in bearing is located at lubeline hole.
- C. On the side of bearing housing will be two 1/4"-20 tapped holes for set screws to secure bearing. Drill into holes through teflon bushing with 3/16" drill.
- D. Use a 1/4"-20 tap and start threads into the teflon bushing; one or two complete threads is sufficient.
- E. Install 1/4"-20 set screws and tighten until resistance of the bushing is felt. Do not over tighten as this may distort the bushing.
- F. Clean any shavings from around the hole on the bearing inner diameter.

3. Abrasive #1 (Spring Loaded Packing)

Caution —*The choker ring is under spring tension and may become a dangerous flying object when the set screws are removed. It is recommended that all spring loaded locking assemblies be returned to the factory for rebuilding.*

4. Abrasive #2 (rubber bushings)

- A. Coat the inner diameter of the bushings with a silicon lubricant, such as Dow Corning 111 compound.
- B. Install short bushing.
- C. Install lantern ring—make sure lantern ring aligns with tapped lubeline hole.
- D. Install longer rubber bushing. Check with choker ring to insure approximately 1/32" compression on rubber bushings.
- E. If using old choker ring, align tapped holes, forcing choker ring against its seat; install both set screws and tighten. If using new choker ring, remove longer bearing, seat choker ring, drill two 13/64" diameter holes 180 degrees apart; tap 1/4"-20NC with the seam as center. Remove and install longer bushing and push choker ring until seated. Install set screws.

F. 724-H, 824-H & 924-H bearing housing assembly.

For each 3-piece bushing set, (1) bushing must have lubrication grooves opened at the closed end. This applies to bronze and cast iron only. They can be filed or ground to make grooves continuous through bushing.

Support housing as described in Section A. Press first bearing bushing with closed end down, aligning one groove with lube hole in housing, until flush with nose end of housing. Second bushing has continuous grooves. Align grooves with first bushing and press until it touches first bushing. If lube hole in housing is completely blocked, drill a 1/4-3/8" dia. hole through bushing at housing lube hole. Make sure hole enters bushing at lubrication groove. Deburr I.D. of bushing at hole. Flush with air or other means to insure a clean bushing. Press third bushing with closed groove end up, until it clears vent holes in housing. If required, press choker ring into housing until it bottoms out.

VII. ASSEMBLY OF COLUMN PIPE

1. Clean all mating machine surfaces. Remove any burrs which may have developed during dis-assembly.

2. Check shaft for straightness. Clean thoroughly.

Support shaft at ends with "V" blocks and indicate at center. A maximum **TIR** of .0015/per foot of length is within acceptable limits. A runout greater than this tolerance would necessitate a new shaft or straightening. Pay particular attention to the bearing areas of the shaft, looking for scoring or eccentricity. Diameter should be nominal. (+.0000 to -.0015).

3. Slide intermediate bearing housing (24) over shaft and into the groove of the top column pipe flange (23). Turn housing so grease connection in housing lines up with hole in column pipe. Install flange bolts (27).

4. Slide bottom column pipe (23) over shaft and make sure that lubrication port lines up with lubrication lines, and also is in alignment with lubrication port in upper column pipe assembly (23). Replace capscrews, nuts and washers (27,10A,10B) and tighten.

5. Place bottom housing (24) over end of the shaft and onto bottom column pipe flange (23). Align flange bolt holes and grease port in housing (24) with hole in bottom column pipe (23).

VIIIA. ASSEMBLY OF LIQUID END —700 SERIES

1. Place bearing housing gasket (34) on column flange and position casing so that pump discharge flange lines up with discharge companion flange on pipe assembly. Replace casing capscrews (11) and tighten.

2. Replace impeller key (17) in shaft and slide impeller (30) on shaft, lining up keyway and key. Insert a block of wood in the impeller eye area and tap impeller onto shaft. Replace the impeller washer, lock washer and nut on shaft and tighten.

3. Replace casing gasket on casing, and replace suction head and bolts. Tighten suction head bolts.

4. Reconnect lubrication line(s)(43).

5. Turn pump shaft by hand to check for free rotation.

VIIIB. ASSEMBLY OF LIQUID END —800 SERIES

1. Replace case adaptor (33) with top gasket (34) or casing on the 2x1 1/2 x12. Bolt to column.

2. Replace Woodruff key (17) in shaft and slide impeller (30) on the shaft lining up keyway and key. Insert a block of wood in the impeller eye area and tap impeller into shaft taper. Replace impeller washer (19) and castellated nut on shaft and tighten. Insert cotter pin (20) through castellated nut (18) and drilled hole in shaft thread and bend back.

3. Replace case gasket and casing so that pump discharge flange lines up properly with discharge companion flange/ elbow/pipe assembly. Replace casing capscrews(11) and tighten. (Not required for 2x 1 1/2 x12).

4. Replace suction head if required.

5. Reconnect grease line(s)(43).

6. Turn pump shaft by hand to check for free rotation.

VIIIC. ASSEMBLY OF LIQUID END — 900 SERIES

1. Replace impeller key (17) in shaft and slide impeller (30) on shaft, lining up keyway and key. Insert a block of wood in the impeller eye area and tap impeller onto shaft. Replace impeller, lockwasher and bolt on shaft and tighten.

2. Place casing gasket (34) on top casing adaptor (33) and position casing so that pump discharge flange lines up with discharge companion flange on pipe assembly. Replace casing capscrews (11) and tighten.

3. Reconnect lubrication lines(s)(43),

4. Turn pump shaft by hand to check for free rotation.

5. 900 (Vortex) units must be removed from the sump and laid horizontally to replace the thrust bearing.

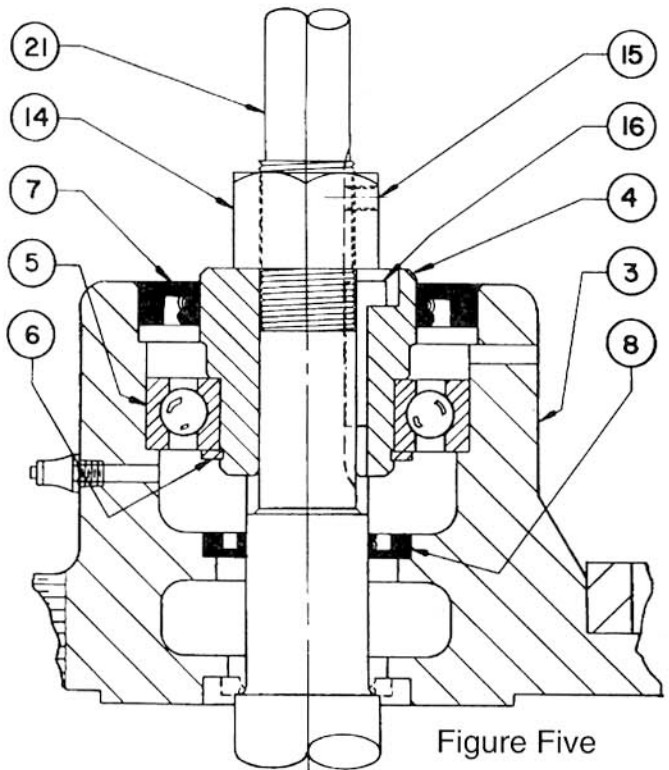

Figure Five

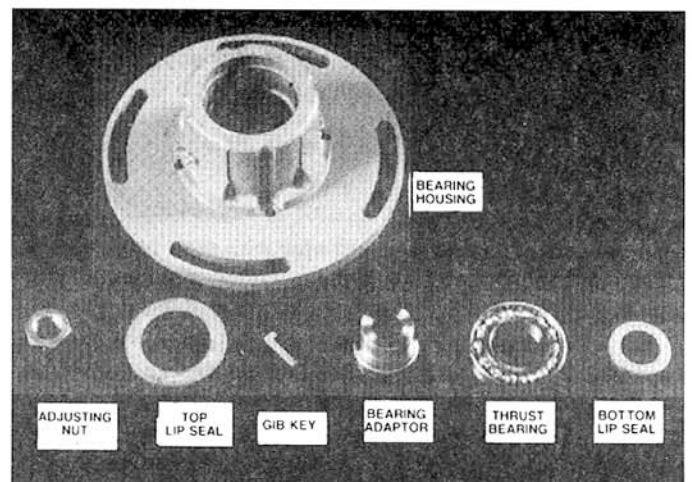

Figure Six

IX. TO REMOVE MOTOR SUPPORT AND THRUST BEARING HOUSING (With Pump Removed From Sump)

Motor may be removed from motor support. Remove plate, bolts, nuts and washers (10,10A,10B) holding motor support (1) and thrust bearing housing (3) to support plate (29). Slide motor support (1) up and off thrust bearing housing (3). Unscrew column bolts (11) to separate column (23) from thrust bearing housing (3). Illustration fig. 5 may be helpful.

X. TO INSPECT OR REPLACE THRUST BEARING AND LIP SEALS

Note: 700 (sewage) and 800 (sump) units may have the thrust bearing replaced without removing the pump unit from the sump.

1. Make sure the electrical service is disconnected. Remove motor capscrews (2A) and lift motor from motor support (1). Remove coupling insert (12B) and the bottom coupling half (12C) from pump shaft (21). Also remove coupling shaft key (13). **Refer to Fig. 5.**
2. Remove Allen head set screw (15) from hex adjusting nut (14) and remove hex nut by turning it counterclockwise looking down onto shaft.
3. Remove gib key (16) from bearing adaptor (4) by raising and lowering shaft until key works up until it can be removed with pliers. Remove top bearing lip seal (7) by piercing with a screwdriver and prying out from thrust bearing housing (3). Lift the entire bearing assembly consisting of bearing adaptor (4) and bearing (5), up and out of the thrust bearing housing (3). Removal of the bottom thrust bearing housing lip seal (8) is now possible.
4. Remove thrust bearing (5) from bearing adaptor (4). **Illustration Fig. 6** should be helpful at this point.
5. To re-assemble, press new lip seal (8) into bottom of thrust bearing housing (3). Handpack thrust bearing (5), spring up, with grease. Next, press thrust bearing (5) onto bearing adaptor (4) **with the wider space between the bearing races facing up. This is an angular contact bearing and it must be installed correctly.** If "thrust" is stamped on inner race, position up—if on outer race, position down.
6. Slide thrust bearing assembly over shaft and gently tap top of the adaptor (4) with a clean block of wood to seat on housing shoulder. Line up adaptor key slot with pump shaft key slot and insert gib key (16). Make sure gib key (16) is flush with or below top of bearing adaptor (4). Gently tap lip seal (7) spring side down into housing (3) making sure it is flush with housing.
7. See impeller adjustment for next procedure.
8. **Lubricate new bearing now with recommended grease through grease fitting until grease exits out relief hole.**
9. Replace bottom coupling half (12C) on pump shaft and insert shaft coupling key (13). Replace the motor support (1) and secure with four (4) bolts, nuts and washers (10,10A,10B). Place the motor on the motor support (1) and jog starter to re-check motor rotation. Replace coupling insert and engage coupling halves. Lock all set screws.
10. Follow installation instructions.

VERTIFLO PUMP CO., INC.
7807 Redsky Drive
Cincinnati, Ohio 45249

e-mail sales@vertiflo.com
world wide web: <http://www.vertiflo.com>

VERTIFLO