

VERTIFLO

PUMP COMPANY

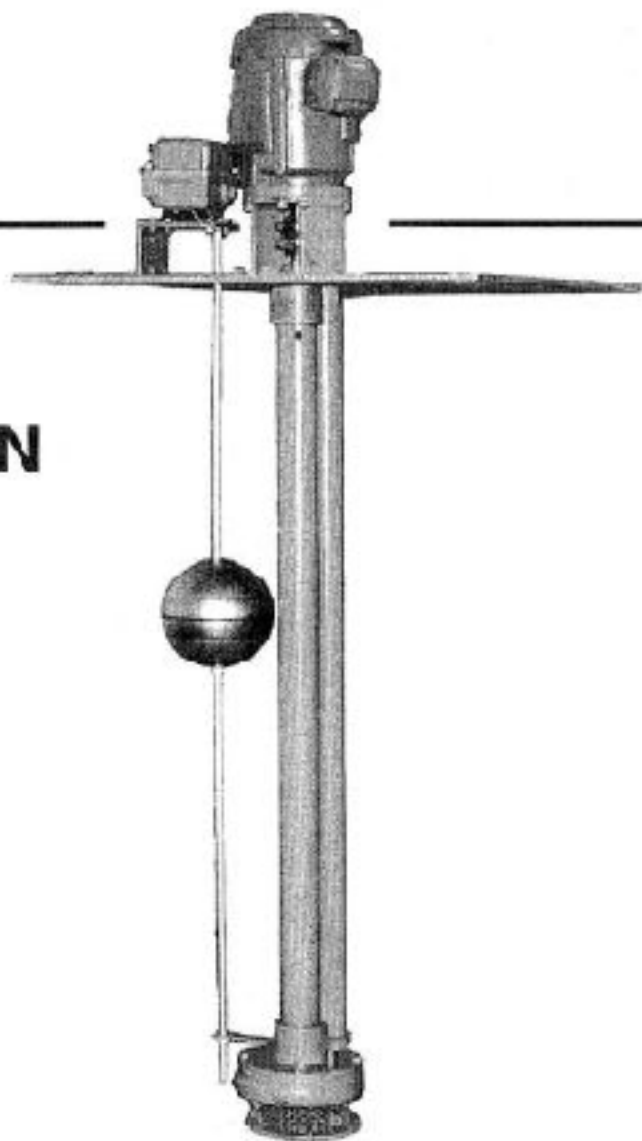

MODEL 814 VERTICAL IMMERSION SUMP PUMPS

Installation, Operation & Service Instructions

IMPORTANT Safety Precautions

In order to minimize the risk of accidents in connection with the service and installation work, the following rules should be followed:

1. Never work alone. Use a lifting harness, safety line and a respirator as required. Do not ignore the risk of drowning!
 2. Make sure that there is sufficient oxygen and that there are no poisonous gases present.
 3. Check the explosion risk before welding or using electric hand tools.
 4. Do not ignore health hazards. Observe strict cleanliness.
 5. Bear in mind the risk of electrical accidents.
 6. Make sure that the lifting equipment is in good condition.
 7. Provide a suitable barrier around the work area, for example, a guard rail.
 8. Make sure you have a clear path of retreat!
 9. Use safety helmet, safety goggles and protective shoes.
- Follow all other health and safety rules and local codes and ordinances.

Handling Instructions

Do *not* put any strain on column and shaft assembly. Lifting equipment should be attached to motor support bracket or cover plate. Avoid bending of column pipe and shaft assembly.

I. INSTALLATION INSTRUCTIONS

Vertiflo Pump Company's vertical Wet Pit Pump, Model 814 is completely assembled, carefully adjusted, and prelubricated at the factory before shipment.

1. Remove banding straps and cap screws holding pump to skid.
2. Remove coupling guard, if supplied, and turn pump by hand, checking for free rotation.
3. If motor is not mounted, remove motor coupling half (12A) and install on motor shaft. Do not tighten set screws until after motor installation.
4. If float switch is supplied, proceed as follows:

Note: Float collars (52) use a stainless set screw which is very effective at holding collar in position with minimum torque. Overtightening will strip threads in collar.

Assemble float rod (51) and collars (52) as shown in figure (1). (If other than Square D switch is used, see their instructions for assembly.)

Position and set screw float collar (54D approximately 4" below pump shut off level. Position float collar (54C) approximately 3" above pump startup level.

Position (54A) and (B) on each side of switch arm with sufficient space to allow free movement of arm. (Approximately 1/2" each). Manually slide float ball through its cycle to assure unobstructed movement of float rod, collars and float.

5. If supplied with a **highwater alarm**, install one of the 1/2"x12" pipes in the tank side of the 1/2" pipe coupling welded to the cover plate. If supplied with a **mercury switch**, install switch before inserting into sump.

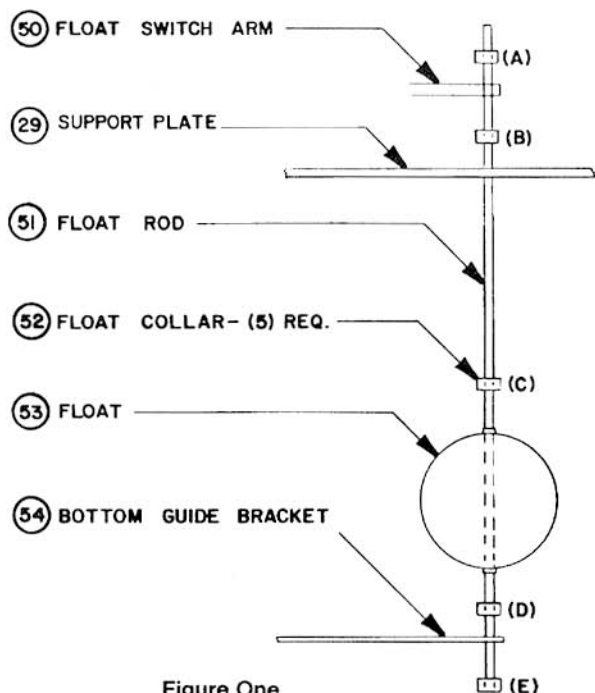

Figure One

6. Lift pump by the support plate or motor support; carefully lower unit into sump. Check to insure that support plate is setting flat on top of sump or support ring. Secure plate by bolting. Check again for **free** rotation.

7. After installation of pump in sump per following these instructions, the compensation spring in switch can be adjusted as follows:

8. Connect discharge piping. If unit is supplied with a flange, tighten to proper location. **Factory flanges are hand tight only. No piping strain is allowed on the pump assembly.** Check again for free rotation.

9. Connect power lines to motor leads as shown on the wiring diagram of the motor for specific line voltage used. Check, and be sure starter and overload protection is proper for specific voltage and for the amperage rating. Follow all state and local wiring codes.

10. Wire float switch according to instructions supplied with float switch. If supplied with a high water alarm, install the remaining 1/2" pipe in top of pipe coupling, with high water alarm screwed on top. Wire to appropriate device or panel. All wiring should be done by a qualified electrician and according to all codes and regulations.

11. Jog motor quickly to check for proper rotation with **couplings disengaged**. A shaft rotational arrow is marked on the motor support, with rotation clockwise when looking down on the motor. Slide coupling together and set screw. Reverse rotation may cause pump damage.

12. Install coupling guard if supplied.

13. Close discharge gate valve. Start unit. Open valve slowly to desired flow and head. Pump should run smoothly, free of vibration. If rubbing is felt, check for piping strain and check **impeller adjustment, section II.**

II. IMPELLER ADJUSTMENT

1. Disconnect power to motor and all controls.
2. Remove coupling guard if supplied.
3. Remove set screw (15) from bearing adaptor (4).
4. Loosen bearing adaptor allowing shaft (21) to drop.
5. If shaft does not drop, lightly tap top of adjusting nut. Use the coupling to turn shaft to assure impeller is against the case (31). Turn bearing adaptor to first set screw for proper running clearance.
6. Align one of the set screw holes in bearing adaptor with keyway in shaft (21).
7. Insert set screw (15) into bearing adaptor and tighten. Do not tighten against the threads of the shaft.
8. Check for free rotation.
9. Reinstall coupling guard.

III. LUBRICATION

1. Carbon lineshaft bearings—applications with little or no abrasives, lubrication is provided by the product pumped with no external lubrication required. If abrasive concentration is medium, external lubrication is required; either clean water or a liquid compatible with the product being pumped. If abrasive concentration is heavy, a

solenoid valve should be supplied and wired to open 16 to 20 seconds before pump operation, to initially flush the bearings.

2. Motor bearings should be lubricated in accordance with the manufacturer's recommendations.
3. Thrust bearing is permanently lubricated and sealed.

IV. THRUST BEARING REPLACEMENT (with or without removing pump from sump)

1. Eliminate any possible electrical sources to pump and controls.
2. Close discharge valve.
3. Remove motor from pump motor stand, leaving motor coupling flange and insert attached.
4. Remove pump shaft coupling flange and shaft key (13).
5. Remove set screw (15) from pump bearing adaptor (4).
6. Turn bearing adaptor (4) counter clockwise from top view until threads disengage.
7. Bottom lip seal (8) can be removed with a screwdriver and pliers with caution not to damage shaft or threads.
8. Press ball bearing off adaptor; replace with new bearing.
9. Press new lip seal into thrust bearing housing (3) with spring side towards sump.
10. Fill cavity above lip seal to machined counter bore with grease for lip seal lubrication.
11. Slide new bearing and bearing adaptor (4) over shaft (21) until threads engage. Turn clockwise until bearing seats in bore.
12. Replace shaft key (13) and coupling flange.
13. Re-adjust impeller per instructions in Section II.

V. PUMP CONTROL

1. Disconnect all electrical sources or supply lines to pump and controls.
2. Close discharge valve and disconnect from pump.
3. Remove motor from pump.
4. Remove mounting plate anchor bolts.
5. Lift pump unit by motor support or support plate until second strap can be secured to pump case.
6. Lift bottom of unit until level and lower to ground.

Caution: Do not lift by single point on discharge pipe (39) or pump column (23). Serious pump damage may result.

VI. PUMP DISASSEMBLY (impeller removal)

Note: Match mark joining parts for ease in re-assembly.

1. Remove level control accessories or devices if necessary.
2. Remove top discharge pipe nut (40).
3. Remove column to case bolts (33).
4. Remove case and discharge assembly.

5. To remove impeller (30), use strap wrench on pump coupling flange (12C), to hold, and unscrew impeller using strap wrench or wood block between vanes of impeller. Threads are standard right hand.
NOTE: Shaft and impeller can be pulled out together from bottom of pump after thrust bearing removal.

6. For further disassembly follow Section IV.
7. Slide shaft out of column.

VII. LINESHAFT BEARING REMOVAL AND INSTALLATION

Caution: Bushings (25) are made of carbon and are subject to damage if handled improperly.

1. Disassemble column from bottom housing and intermediates.
2. Press old bushings (25) out.
3. If bushings have external or product flush lines, new bushings must be aligned so that one internal groove is positioned over pipe tapped hole in housing.
4. Press new bushings in housings to same position as old ones.

Caution: Housing and bushing must be positioned or aligned carefully. Mis-alignment will cause bushing breakage or fractures. Do not hit or hammer on bushings!

5. To access bushing to flush lines (if required) carefully drill $\frac{1}{4}$ " diameter through $\frac{1}{8}$ " NPT hole in side of bearing housing (use high speed slow feed). Drilled hole must intersect internal groove of bushing.

VIII. REASSEMBLY

1. Thread columns, thrust bearing, bottom and intermediate bearing housing together. A non-hardening thread or anti-seizing compound may be used for future ease in disassembly. Make sure all pipe is firmly seated in its corresponding housing.
2. Replace impeller on shaft by placing shaft in soft jaw vice, (or between wood blocks). Place a drop of loctite or equivalent adhesive on threads of shaft. Screw impeller on shaft and tighten.
3. Carefully insert coupling end of shaft into bottom bearing housing until impeller contacts housing. Use caution to prevent hitting carbon bushings or top of seal with top shoulder of shaft which will cause damage.
4. Replace case gasket (34), case (31), and discharge assembly with top pipe nut. Adjust nuts on each side of plate to prevent any pipe strain on case.
NOTE: If case to column bolts do not match, the four outside $\frac{1}{2}$ " hex head screws on top of plate with flat washers can be loosened. Turn column assembly until holes match, then retighten.
5. Follow instruction in Section IV for thrust bearing housing re-assembly.
6. Replace pump into sump per installation instruction Section I.

ITEM DESCRIPTION

- 1 Motor Support
- 2 Cap Screw
- 3 Thrust Bearing Housing
- 4 Bearing Adaptor
- 5 Thrust Bearing
- 8 Lip Seal
- 10A Capscrew (4 required)
- 10B Lock Washer (4 required)
- 11A Capscrew (4 required)
- 11B Lock Washer (4 required)
- 12A,B,C Coupling
- 13 Shaft Key
- 15 Bearing Adaptor Set Screw
- 21 Shaft
- 23 Column
- 24 Bearing Housing
- 25 Line Shaft Bearing Housing
- 27 Intermediate Bearing Housing
- 29 Support Plate
- 30 Impeller
- 31 Casing
- 34 Case Gasket
- 35 Strainer
- 36 Elbow
- 39 Discharge Pipe
- 40 Discharge Pipe Lock Nut (2 required)

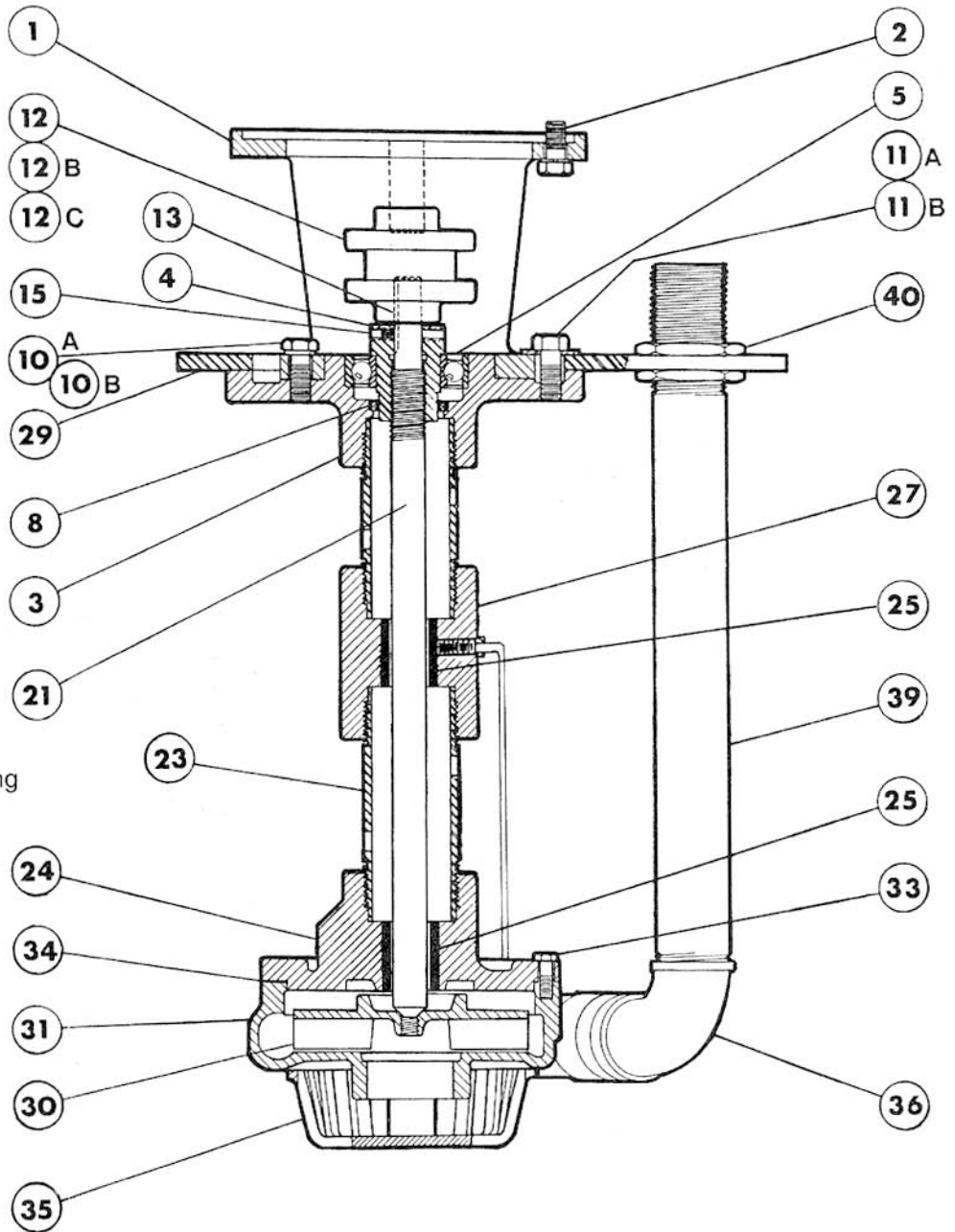

Refer to Pump Serial Number and Part Item Number when ordering parts.

VERTIFLO PUMP COMPANY
 7807 REDSKY DRIVE
 CINCINNATI, OHIO 45249
 513-530-0888 Fax: 513-530-0893

