

VERIFLO SERIES 600, MODELS 629 & 636

Quality Design Features Assure Long, Trouble-Free Service



WIDE RANGE OF APPLICATIONS:

- Industrial Spray Washer
- Pickling / Bonderizing
- Spray Booths
- Coolant Systems
- Filtration Systems
- Pollution Control
- E-Coat Paint Systems

CAPABILITIES:

- Capacities to 3000 GPM
- Heads to 230 Feet
- Temperature to 180° F
- Column Extensions of 12", 15" & 21"
- Construction: Cast Iron, 316 Stainless Steel Fitted, 316 Stainless Steel, Alloy 20

600

CONSTRUCTION:

Standard

- All iron construction
- Stress-Proof alloy steel shaft
- External impeller adjustment
- Cartridge type thrust bearing housing and cap
- Double row thrust bearing
- Semi-Open impeller with balancing ring and wiping vanes
- 12" flanged column extension
- Steel cover plate
- Schedule 40 discharge pipe
- Cast iron motor support
- Flexible coupling

Options

- Stainless steel fitted, All stainless steel or Alloy 20 construction
- Pump down feature
- Suction piping
- Column extension available for 15" or 21" extensions
- Oversize cover plates
- Fabricated steel chairs for "T" or "U" frame foot mounted motors

Shaft Sizes

Model Number 629.....2 1/4"
 Model Number 636.....2 1/2"

1. Motor Support

Assures positive alignment of motor and pump shaft with register fit. Normal thrust, vertical NEMA C face motor standard. Fabricated steel chair mount is an option.

2. External Impeller Adjustment

Locking jack screws provide impeller adjustment without dismantling pump or piping

3. Bearings

Grease lubricated, heavy-duty ball bearings- Double row thrust bearing standard

4. Power Frame

Heavy duty cast iron, line bored and machined to assure correct alignment of rotating element

5. Column Closure

Replaceable lip seals prevent moisture and dirt from entering lower bearing

6. Cover Plate

Designed for specific unit. Carbon steel standard, alloy plates optional

7. Positive Machine Fits

Machined registered fits of column, power frame, throttle housing and casing

8. Column Pipe

Schedule 40 steel pipe with welded flanges

9. Shaft

Accurately machined, stress-proof steel assures minimum deflection

10. Throttle Bushing

Register fit assures positive alignment between column and casing. Throttle bushing restricts flow of liquid entering column.

11. Impeller

Semi-open design with balancing ring and wiping vanes for wide range of applications. Secured to shaft by taper fit with woodruff key, castellated nut and cotter pin

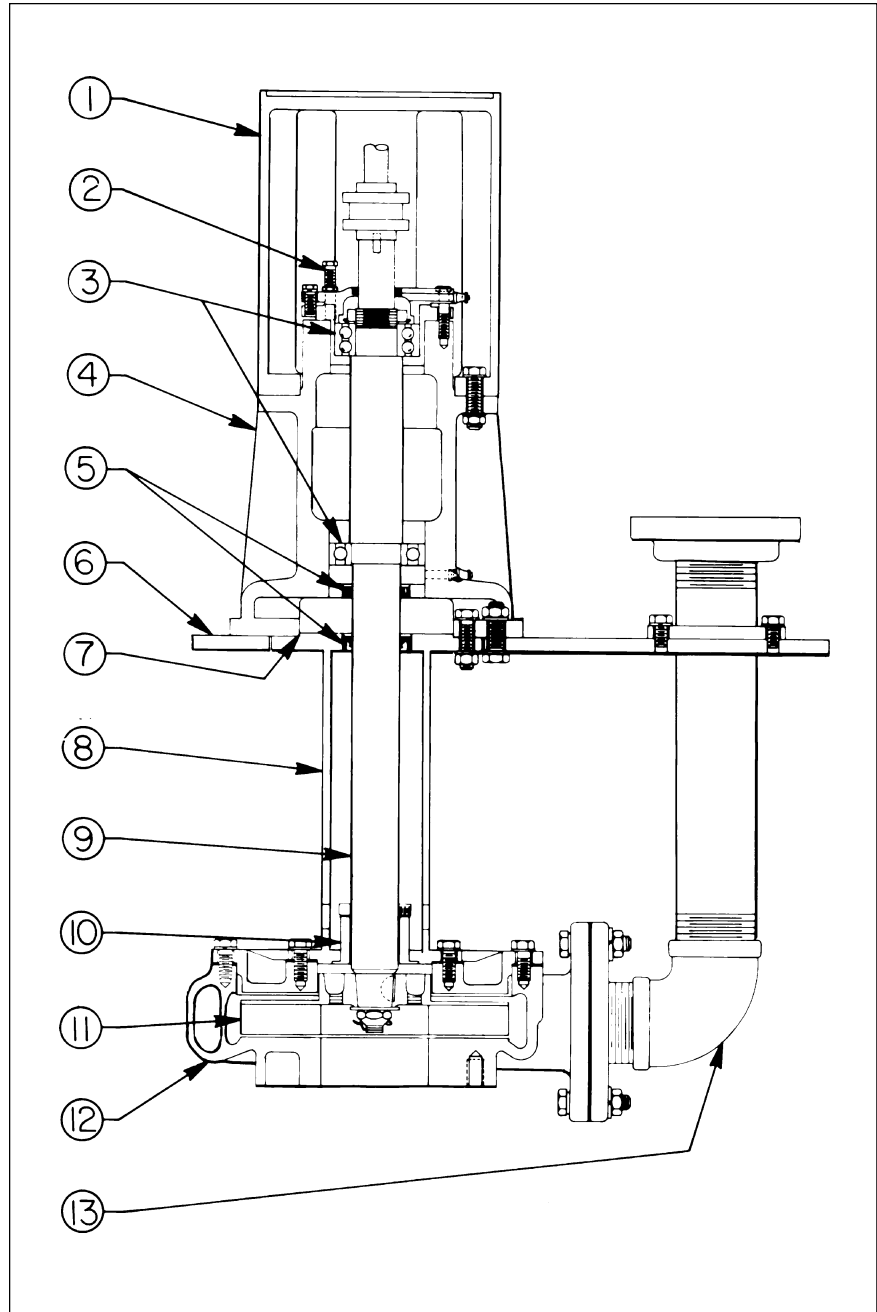

12. Casing

Flanged suction and discharge. Double volute design on all 4 X 3 X 10 and larger sizes

13. Discharge Pipe

1" - 2 1/2" threaded; 3" and larger flanged

VERTIFLO PUMP COMPANY Performance Curves

Curve PV-1525

Series 600
 Size 3 X 2 1/2 X 7
 RPM 1750
 Max Sphere 1

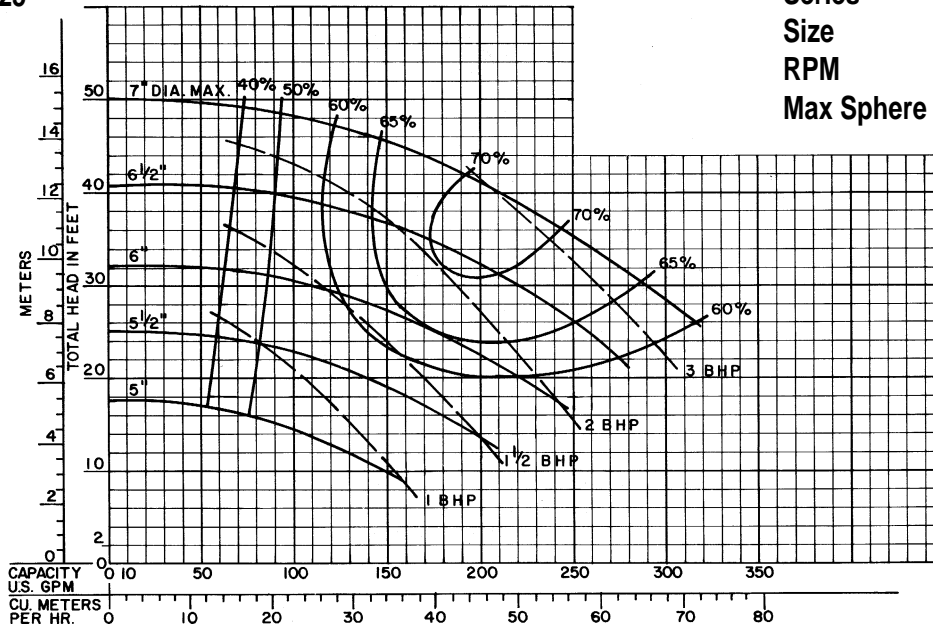

Curve RV-1525

Series 600
 Size 3 X 2 1/2 X 7
 RPM 1150
 Max Sphere 1

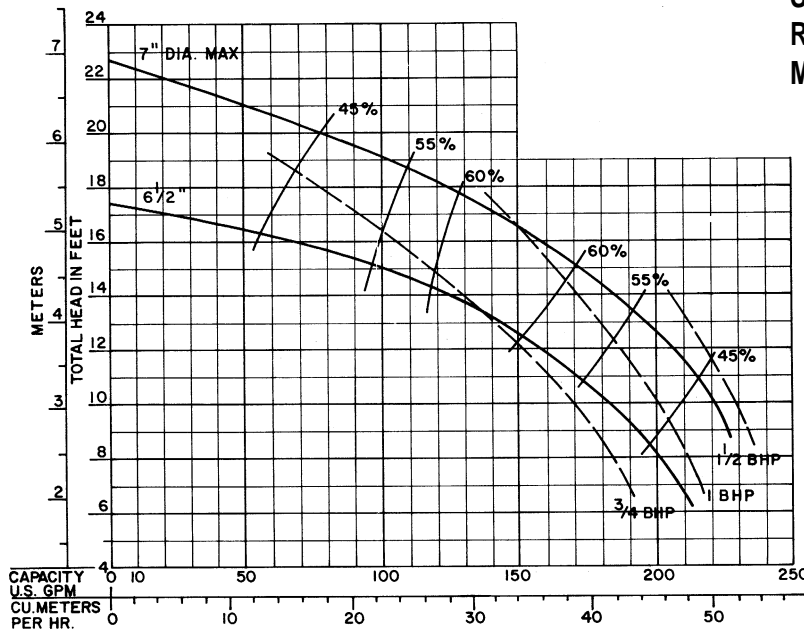

600

Performance at Casing Discharge Flange

Curves Show Performance with Liquid Having Specific Gravity 1.0 Viscosity • 30 SSU

CUSTOMER _____ CUSTOMER NO. _____

PROJECT _____

ENGINEER _____

CONTRACTOR _____

CONDITIONS: _____ GPM _____ TDH _____ HP _____ EFF% _____ IMP. DIA _____

VERTIFLO PUMP COMPANY Performance Curves

Curve AS-1610

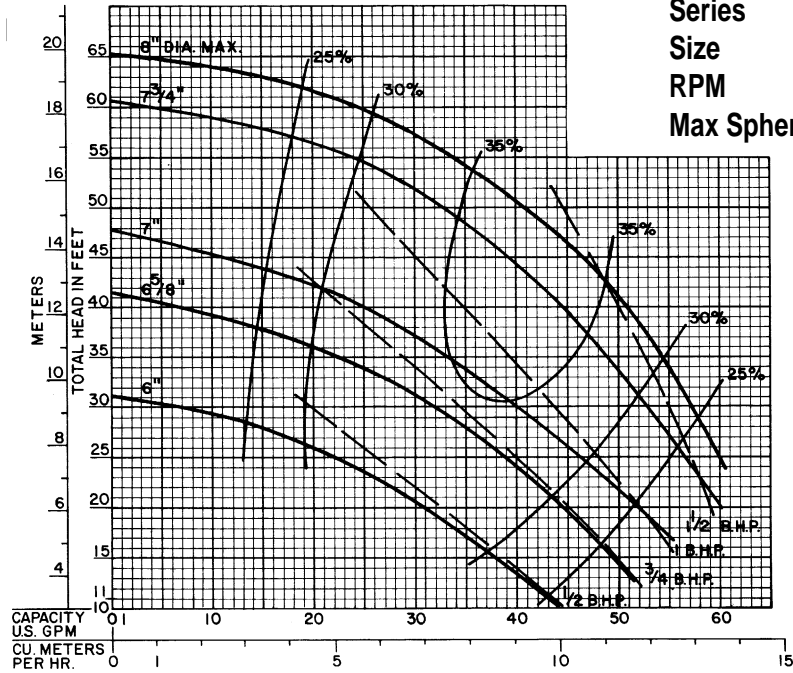

Series 600
 Size 1 1/2 X 1 X 8
 RPM 1750
 Max Sphere 1/4

Curve BS-1610

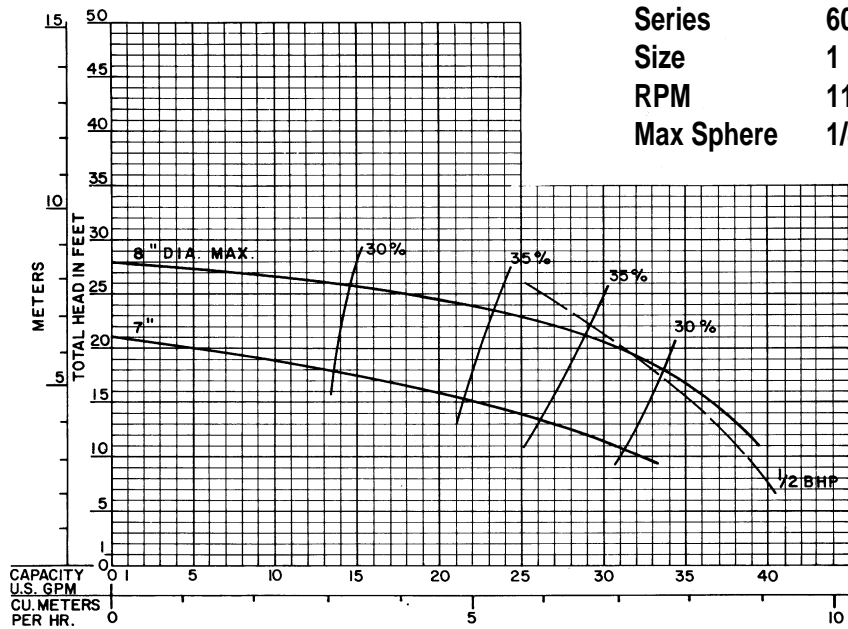

Series 600
 Size 1 1/2 X 1 X 8
 RPM 1150
 Max Sphere 1/4

Performance at Casing Discharge Flange

Curves Show Performance with Liquid Having Specific Gravity 1.0 Viscosity • 30 SSU

CUSTOMER _____ CUSTOMER NO. _____

PROJECT _____

ENGINEER _____

CONTRACTOR _____

CONDITIONS: _____ GPM _____ TDH _____ HP _____ EFF% _____ IMP. DIA _____

VERTIFLO PUMP COMPANY Performance Curves

Curve AS-1612

Series 600
 Size 1 1/2 X 1 1/4 X 8
 RPM 1750
 Max Sphere 5/16

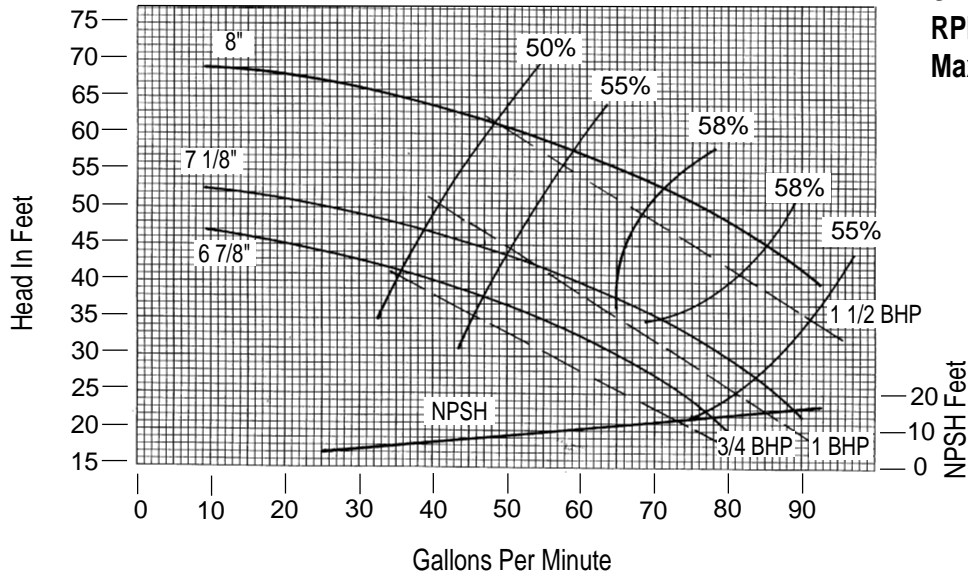

Curve BS-1612

Series 600
 Size 1 1/2 X 1 1/4 X 8
 RPM 1150
 Max Sphere 5/16

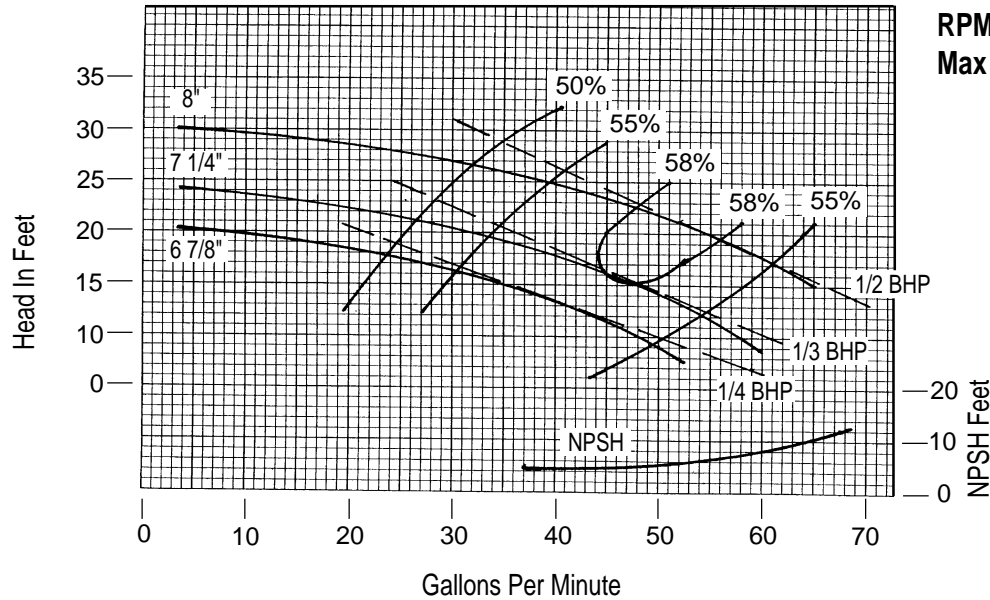

Performance at Casing Discharge Flange

Curves Show Performance with Liquid Having Specific Gravity 1.0 Viscosity • 30 SSU

CUSTOMER _____ CUSTOMER NO. _____

PROJECT _____

ENGINEER _____

CONTRACTOR _____

CONDITIONS: _____ GPM _____ TDH _____ HP _____ EFF% _____ IMP. DIA _____

600

VERTIFLO PUMP COMPANY Performance Curves

Curve BS-1615

Series 600
 Size 2 X 1 1/2 X 8
 RPM 1750
 Max Sphere 7/16

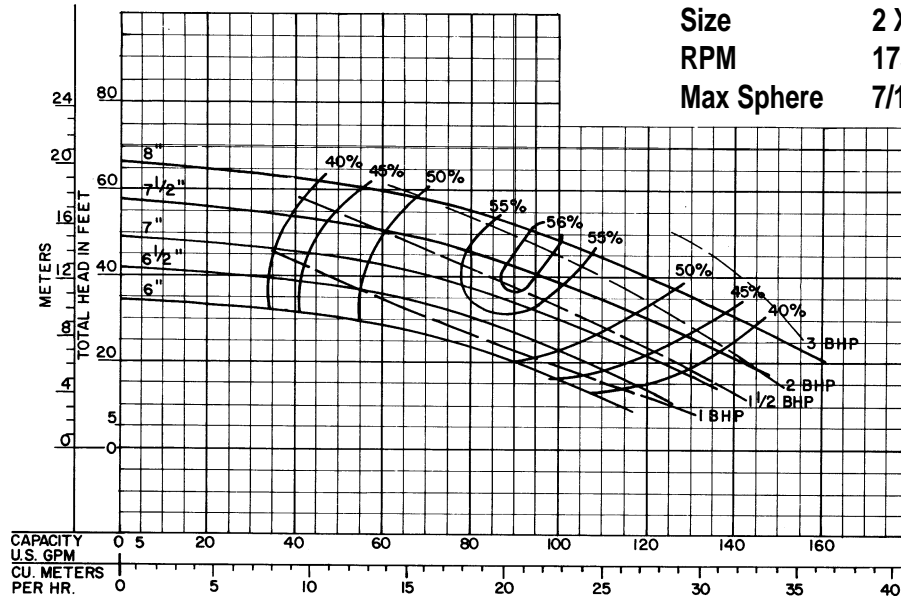

Curve CS-1615

Series 600
 Size 2 X 1 1/2 X 8
 RPM 1150
 Max Sphere 7/16

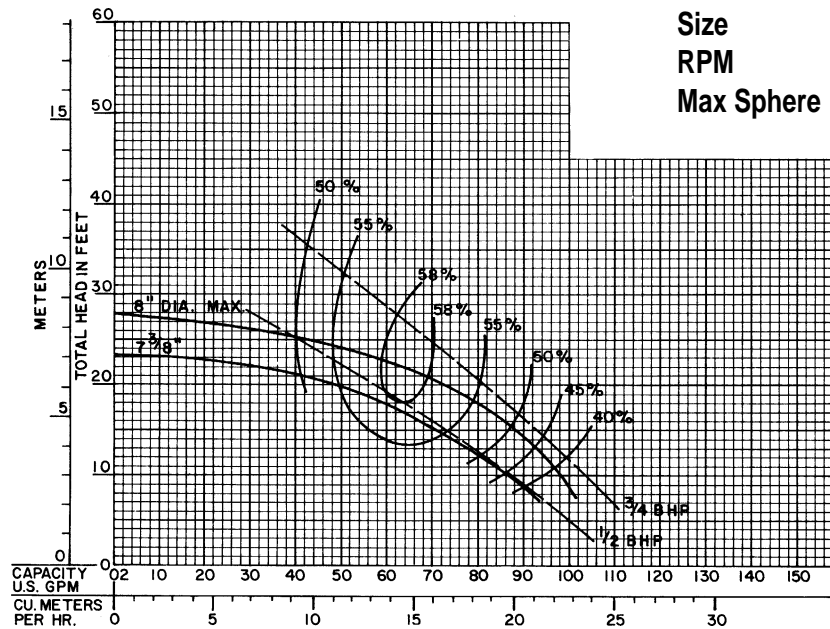

Performance at Casing Discharge Flange

Curves Show Performance with Liquid Having Specific Gravity 1.0 Viscosity • 30 SSU

CUSTOMER _____ CUSTOMER NO. _____

PROJECT _____

ENGINEER _____

CONTRACTOR _____

CONDITIONS: _____ GPM _____ TDH _____ HP _____ EFF% _____ IMP. DIA _____

VERTIFLO PUMP COMPANY Performance Curves

Curve CS-1620

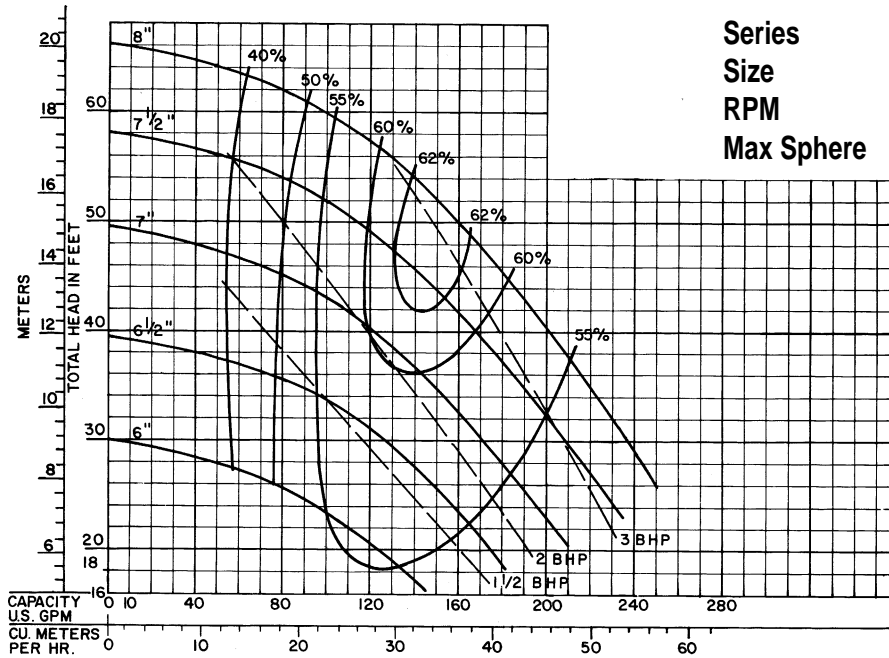

Curve DS-1620

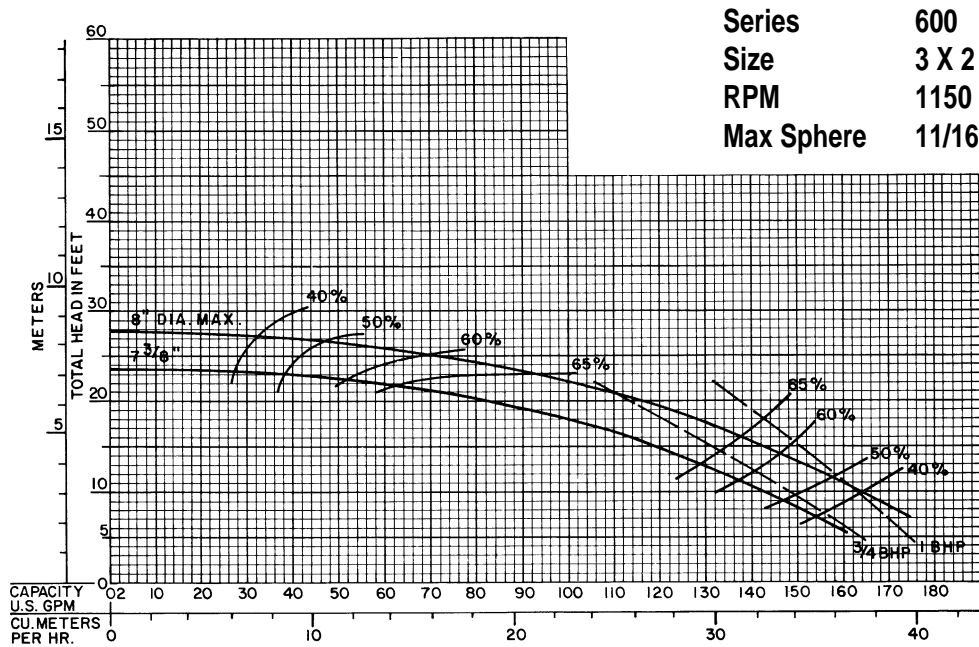

600

Performance at Casing Discharge Flange

Curves Show Performance with Liquid Having Specific Gravity 1.0 Viscosity • 30 SSU

CUSTOMER _____ CUSTOMER NO. _____

PROJECT _____

ENGINEER _____

CONTRACTOR _____

CONDITIONS: _____ GPM _____ TDH _____ HP _____ EFF% _____ IMP. DIA _____

VERTIFLO PUMP COMPANY Performance Curves

Curve CS-1630

Series 600
 Size 4 X 3 X 8
 RPM 1750
 Max Sphere 1 3/16

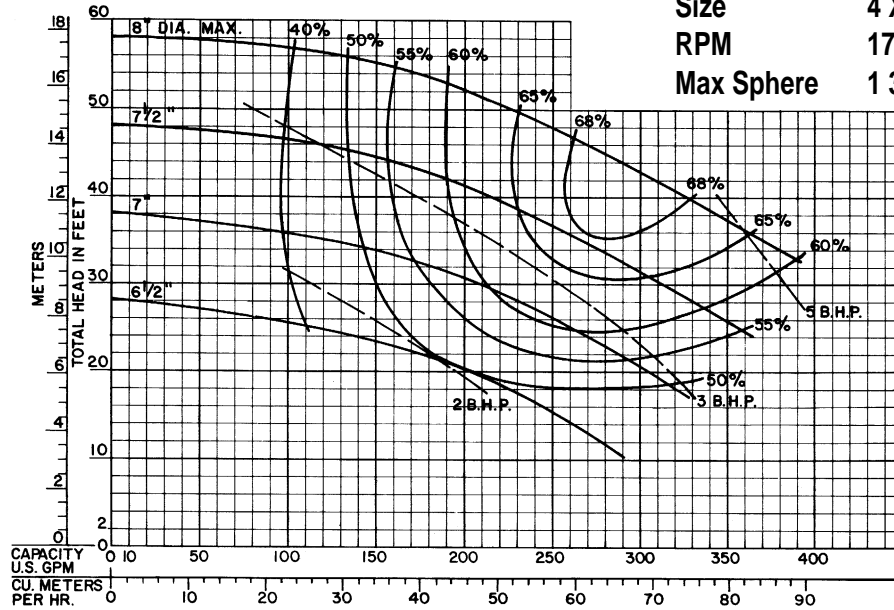

Curve DS-1630

Series 600
 Size 4 X 3 X 8
 RPM 1150
 Max Sphere 1 3/16

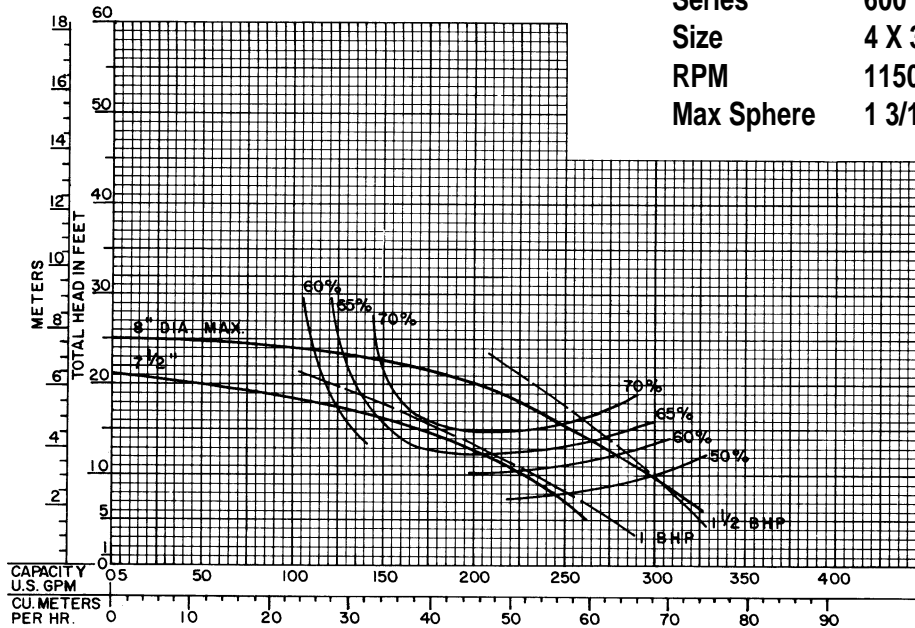

Performance at Casing Discharge Flange

Curves Show Performance with Liquid Having Specific Gravity 1.0 Viscosity • 30 SSU

CUSTOMER _____ CUSTOMER NO. _____

PROJECT _____

ENGINEER _____

CONTRACTOR _____

CONDITIONS: _____ GPM _____ TDH _____ HP _____ EFF% _____ IMP. DIA _____

VERTIFLO PUMP COMPANY Performance Curves

Curve ES-1640

Series 600
 Size 5 X 4 X 8
 RPM 1750
 Max Sphere 15/16

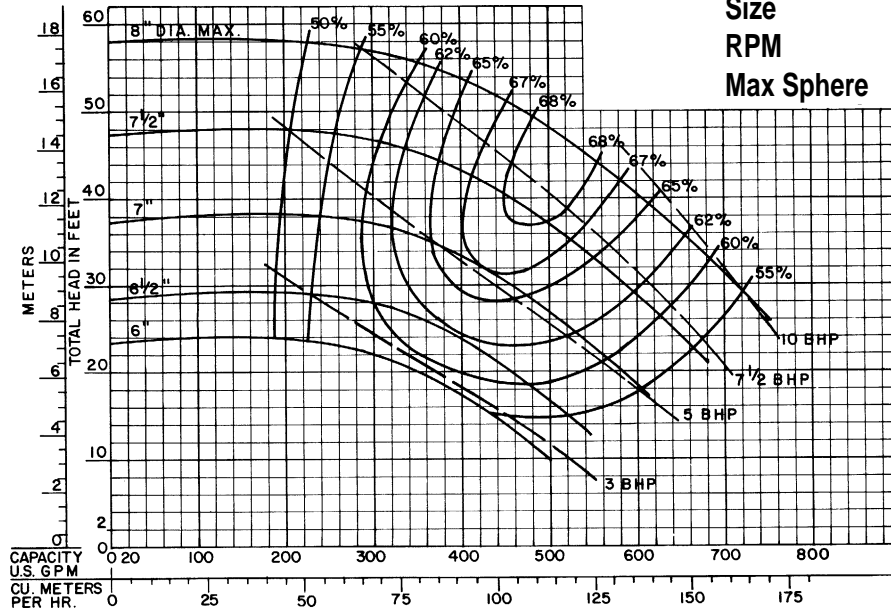

Curve DS-1640

Series 600
 Size 5 X 4 X 8
 RPM 1150
 Max Sphere 15/16

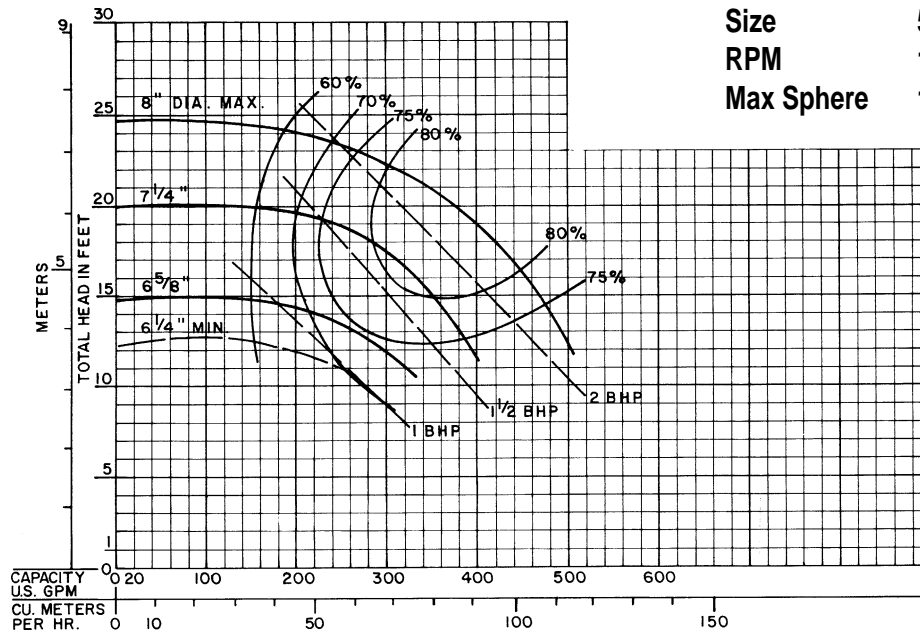

Performance at Casing Discharge Flange
 Curves Show Performance with Liquid Having Specific Gravity 1.0 Viscosity • 30 SSU

CUSTOMER _____ CUSTOMER NO. _____
 PROJECT _____
 ENGINEER _____
 CONTRACTOR _____
 CONDITIONS: _____ GPM _____ TDH _____ HP _____ EFF% _____ IMP. DIA _____

600

VERTIFLO PUMP COMPANY Performance Curves

Curve SM-1915

Series 600
 Size 2 X 1 1/2 X 10
 RPM 1750
 Max Sphere 7/16

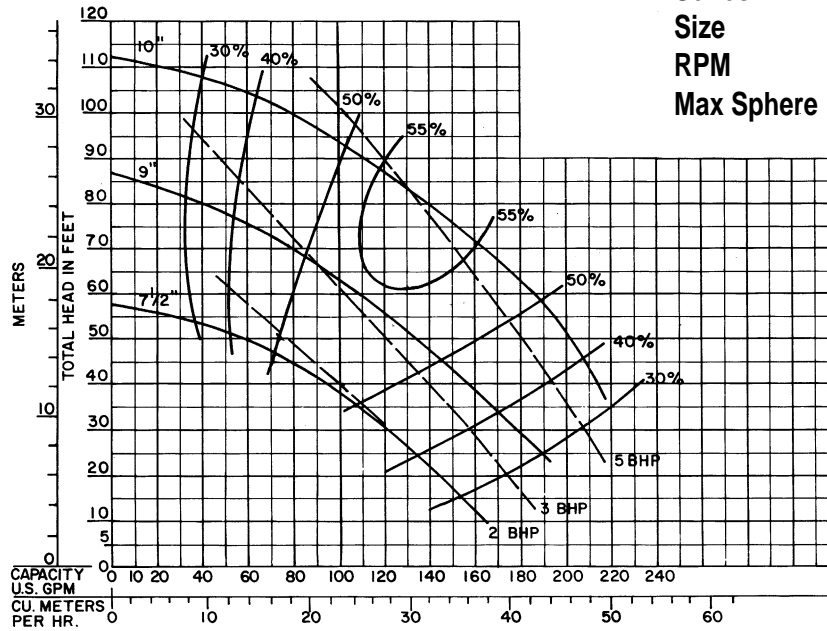

Curve TM-1915

Series 600
 Size 2 X 1 1/2 X 10
 RPM 1150
 Max Sphere 7/16

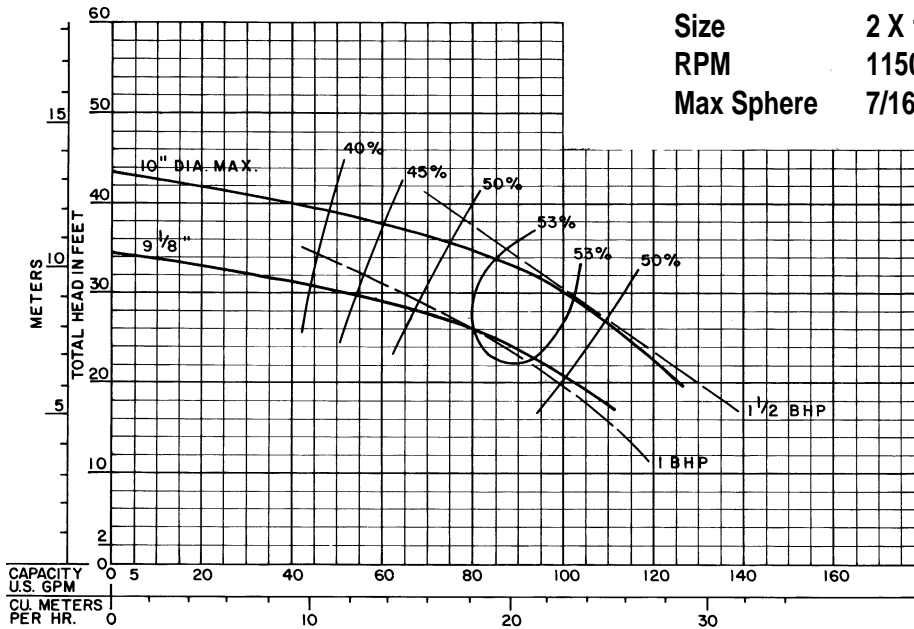

Performance at Casing Discharge Flange

Curves Show Performance with Liquid Having Specific Gravity 1.0 Viscosity • 30 SSU

CUSTOMER _____ CUSTOMER NO. _____

PROJECT _____

ENGINEER _____

CONTRACTOR _____

CONDITIONS: _____ GPM _____ TDH _____ HP _____ EFF% _____ IMP. DIA _____

VERTIFLO PUMP COMPANY Performance Curves

Curve JM-1720

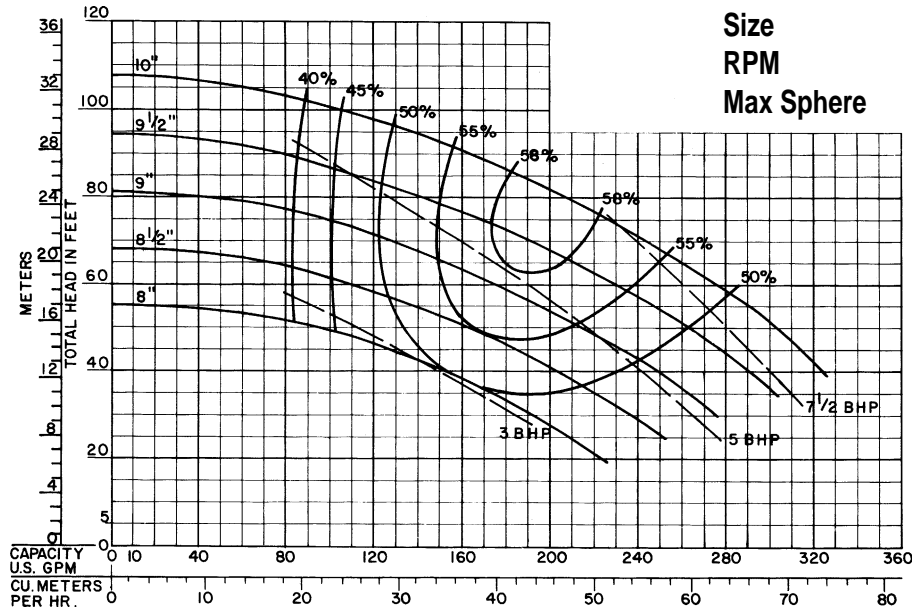

Series 600
 Size 3 X 2 X 10
 RPM 1750
 Max Sphere 11/16

Curve KM-1720

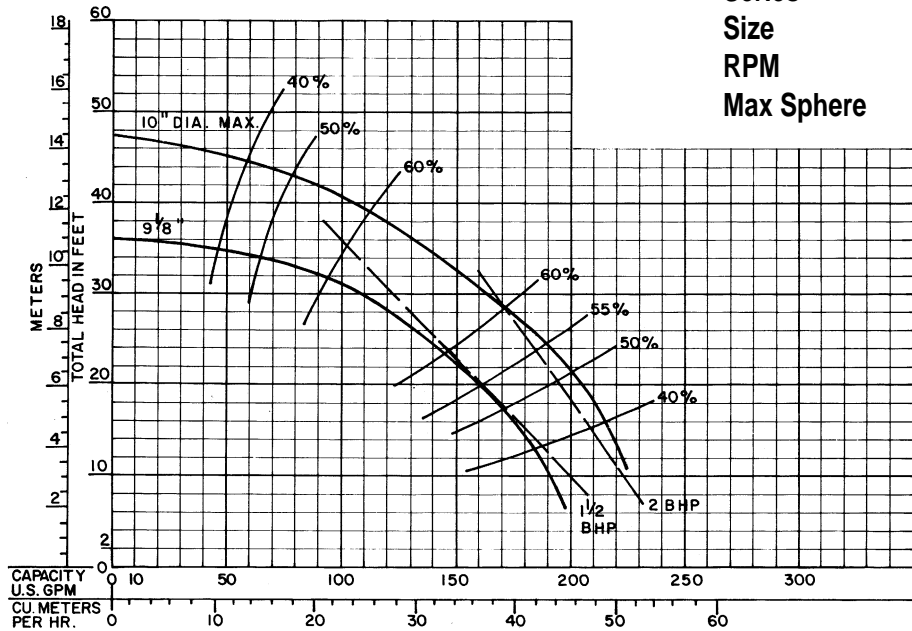

Series 600
 Size 3 X 2 X 10
 RPM 1150
 Max Sphere 11/16

600

Performance at Casing Discharge Flange

Curves Show Performance with Liquid Having Specific Gravity 1.0 Viscosity • 30 SSU

CUSTOMER _____ CUSTOMER NO. _____

PROJECT _____

ENGINEER _____

CONTRACTOR _____

CONDITIONS: _____ GPM _____ TDH _____ HP _____ EFF% _____ IMP. DIA _____

VERTIFLO PUMP COMPANY Performance Curves

Curve RM-1730

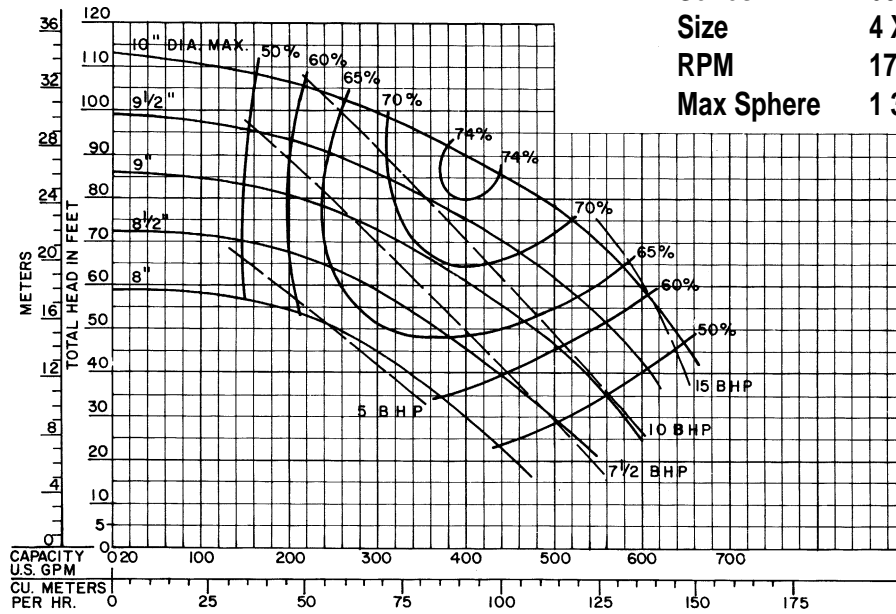

Series 600
 Size 4 X 3 X 10
 RPM 1750
 Max Sphere 1 3/16

Curve SM-1730

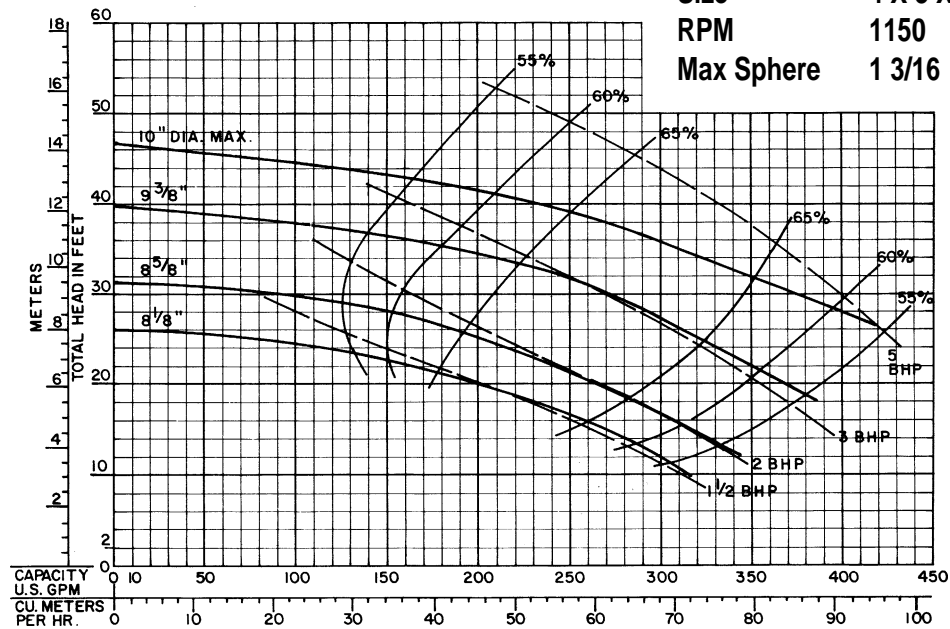

Series 600
 Size 4 X 3 X 10
 RPM 1150
 Max Sphere 1 3/16

Performance at Casing Discharge Flange

Curves Show Performance with Liquid Having Specific Gravity 1.0 Viscosity • 30 SSU

CUSTOMER _____ CUSTOMER NO. _____

PROJECT _____

ENGINEER _____

CONTRACTOR _____

CONDITIONS: _____ GPM _____ TDH _____ HP _____ EFF% _____ IMP. DIA _____

VERTIFLO PUMP COMPANY Performance Curves

Curve TM-1740

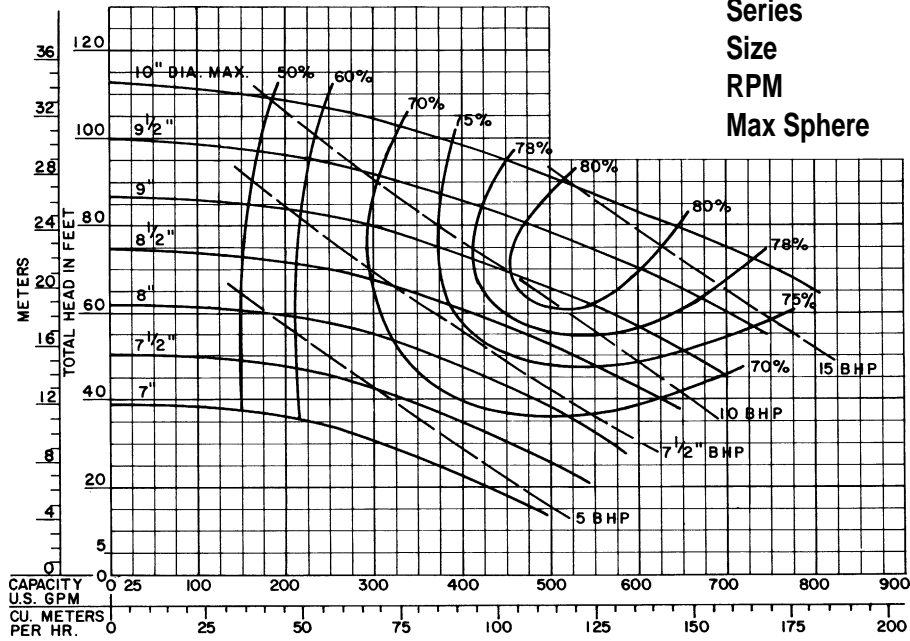

Series 600
 Size 5 X 4 X 10
 RPM 1750
 Max Sphere 1 1/2

Curve UM-1740

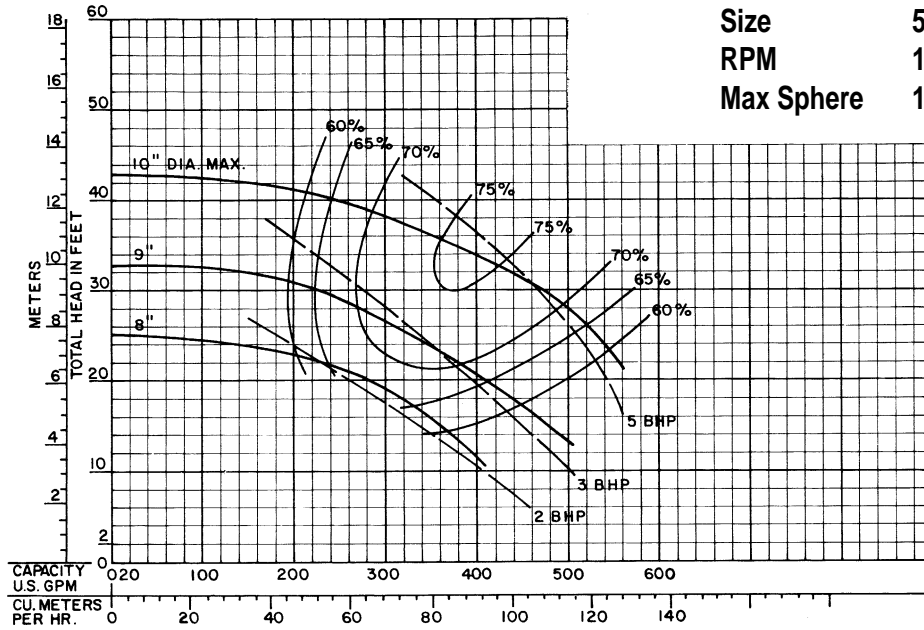

Series 600
 Size 5 X 4 X 10
 RPM 1150
 Max Sphere 1 1/2

600

Performance at Casing Discharge Flange
 Curves Show Performance with Liquid Having Specific Gravity 1.0 Viscosity • 30 SSU

CUSTOMER _____ CUSTOMER NO. _____
 PROJECT _____
 ENGINEER _____
 CONTRACTOR _____
 CONDITIONS: _____ GPM _____ TDH _____ HP _____ EFF% _____ IMP. DIA _____

VERTIFLO PUMP COMPANY Performance Curves

Curve UM-1750

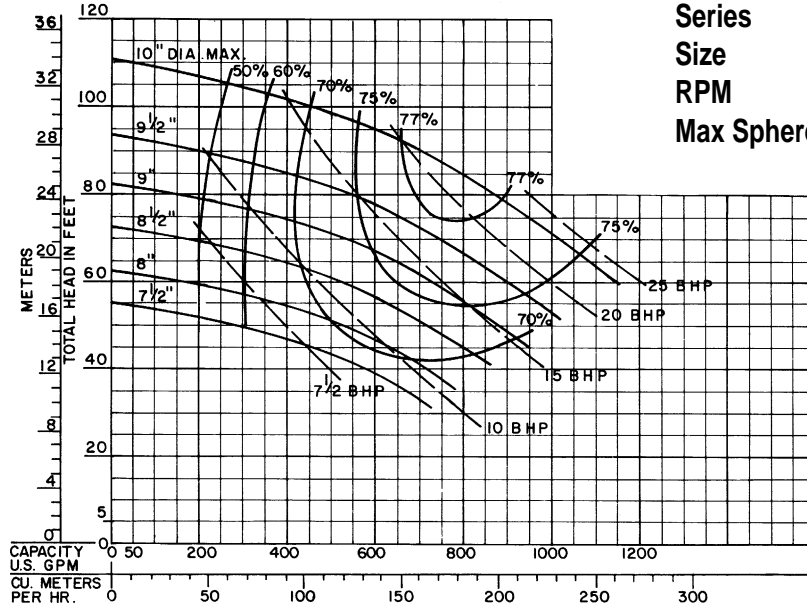

Series 600
 Size 6 X 5 X 10
 RPM 1750
 Max Sphere 1

Curve VM-1750

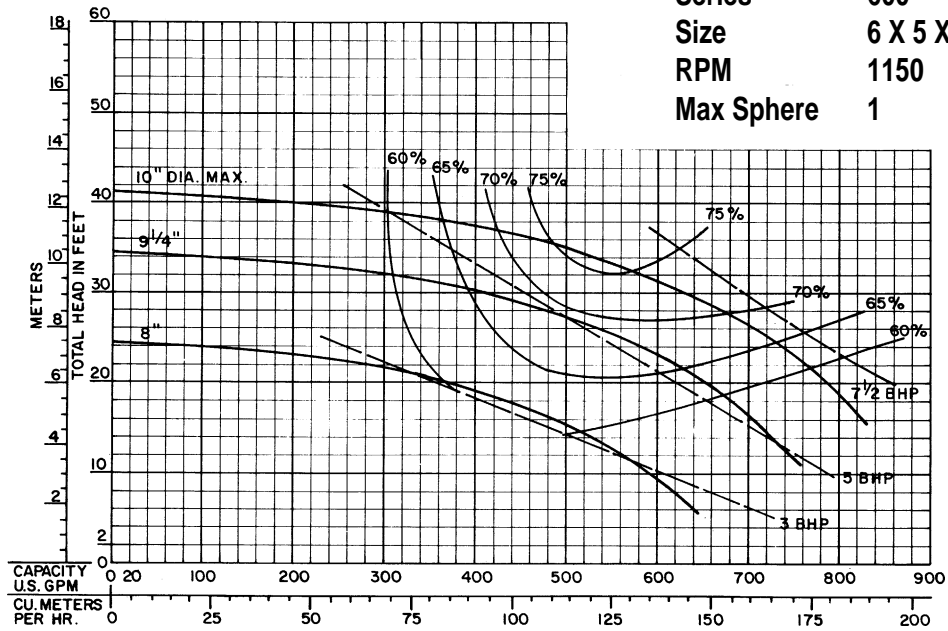

Series 600
 Size 6 X 5 X 10
 RPM 1150
 Max Sphere 1

Performance at Casing Discharge Flange

Curves Show Performance with Liquid Having Specific Gravity 1.0 Viscosity • 30 SSU

CUSTOMER _____ CUSTOMER NO. _____

PROJECT _____

ENGINEER _____

CONTRACTOR _____

CONDITIONS: _____ GPM _____ TDH _____ HP _____ EFF% _____ IMP. DIA _____

VERTIFLO PUMP COMPANY Performance Curves

Curve SM-1750

Series 600
 Size 6 X 5 X 10A
 RPM 1750
 Max Sphere 1 1/2

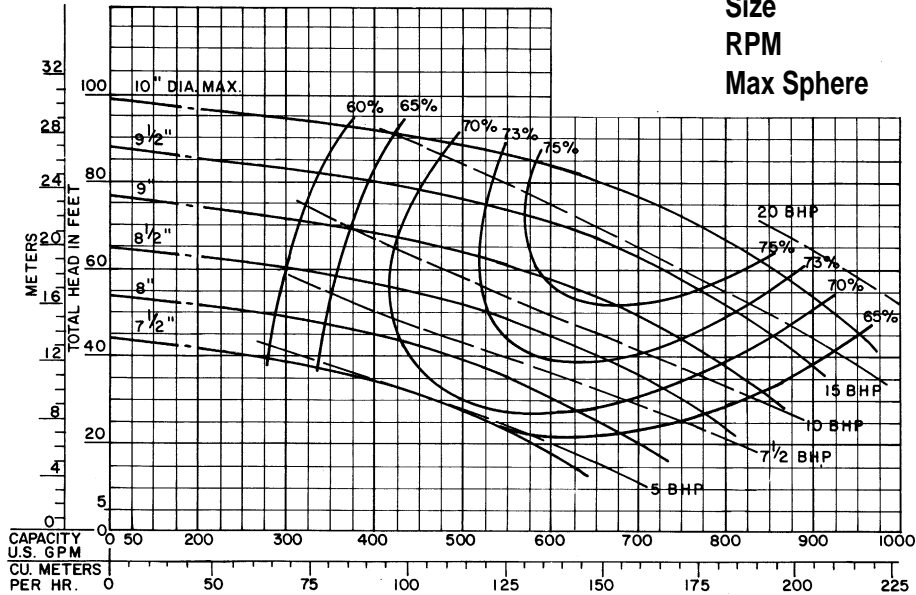

Curve SM-1850

Series 600
 Size 6 X 5 X 10A
 RPM 1150
 Max Sphere 1 1/2

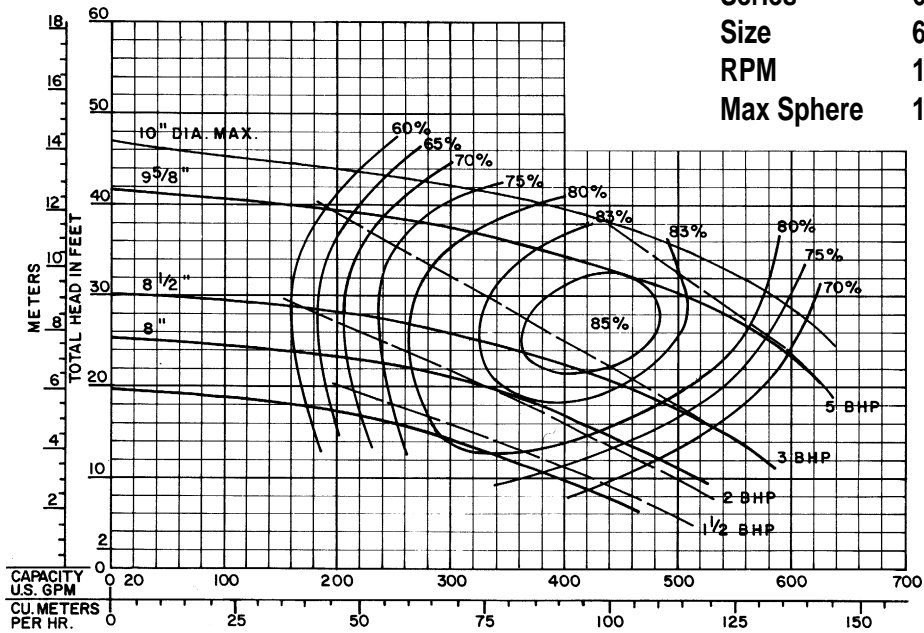

600

Performance at Casing Discharge Flange

Curves Show Performance with Liquid Having Specific Gravity 1.0 Viscosity • 30 SSU

CUSTOMER _____ CUSTOMER NO. _____

PROJECT _____

ENGINEER _____

CONTRACTOR _____

CONDITIONS: _____ GPM _____ TDH _____ HP _____ EFF% _____ IMP. DIA _____

VERTIFLO PUMP COMPANY Performance Curves

Curve TM-1760

Series 600
 Size 6 X 6 X 10
 RPM 1750
 Max Sphere 1 1/8

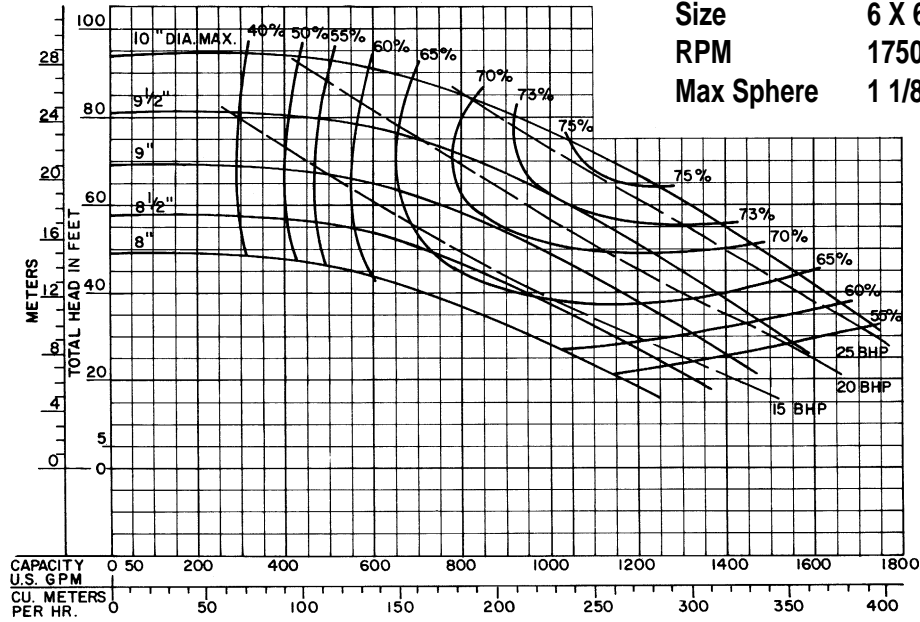

Curve TM-1860

Series 600
 Size 6 X 6 X 10
 RPM 1150
 Max Sphere 1 1/8

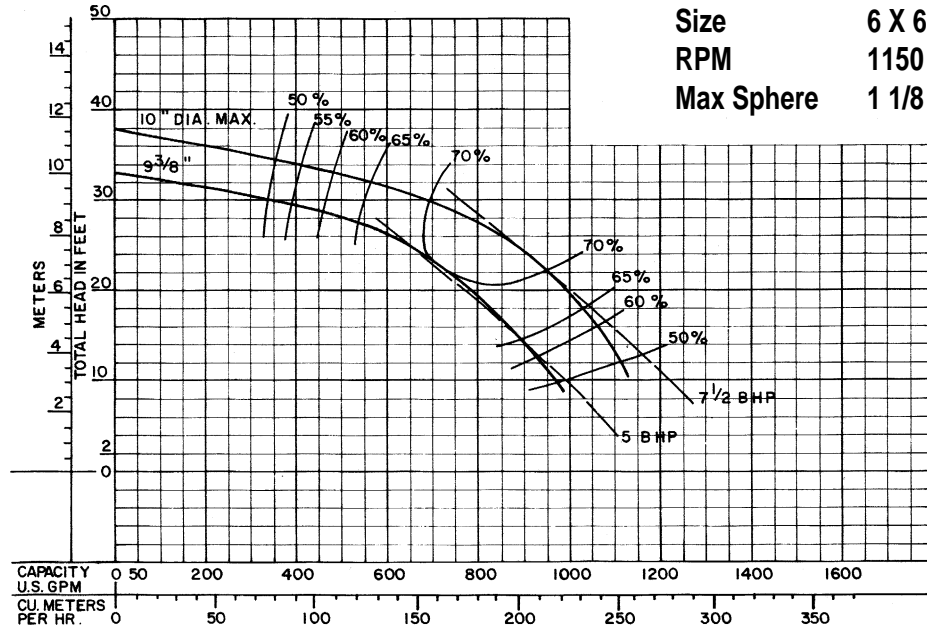

Performance at Casing Discharge Flange

Curves Show Performance with Liquid Having Specific Gravity 1.0 Viscosity • 30 SSU

CUSTOMER _____ CUSTOMER NO. _____

PROJECT _____

ENGINEER _____

CONTRACTOR _____

CONDITIONS: _____ GPM _____ TDH _____ HP _____ EFF% _____ IMP. DIA _____

VERTIFLO PUMP COMPANY Performance Curves

Curve LM-1760

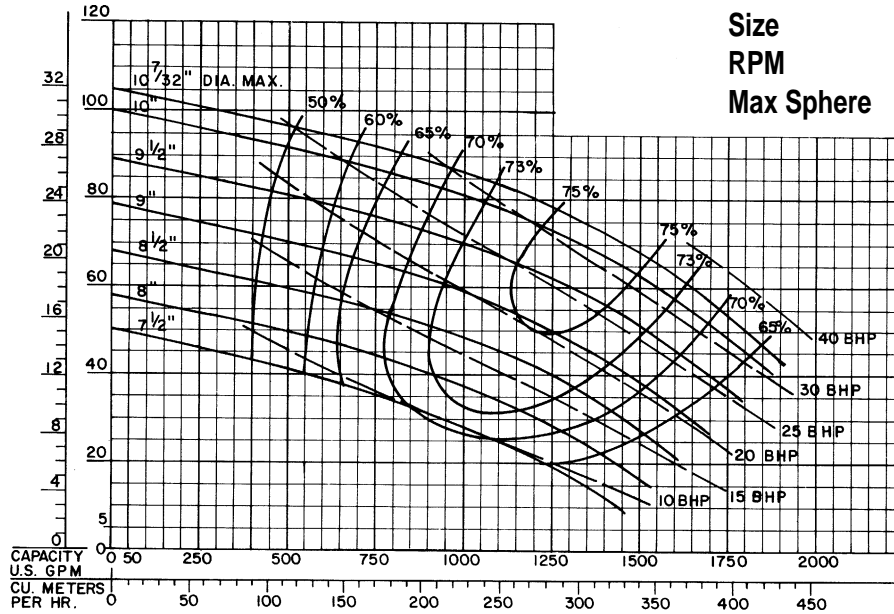

Series 600
 Size 6 X 6 X 10A
 RPM 1750
 Max Sphere 1 9/16

Curve LM-1860

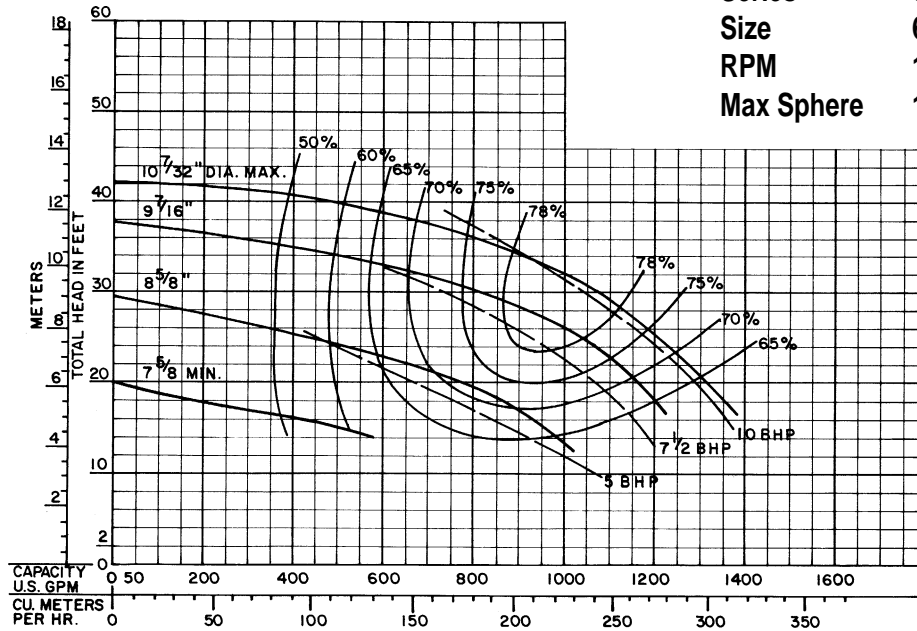

Series 600
 Size 6 X 6 X 10A
 RPM 1150
 Max Sphere 1 9/16

600

Performance at Casing Discharge Flange

Curves Show Performance with Liquid Having Specific Gravity 1.0 Viscosity • 30 SSU

CUSTOMER _____ CUSTOMER NO. _____

PROJECT _____

ENGINEER _____

CONTRACTOR _____

CONDITIONS: _____ GPM _____ TDH _____ HP _____ EFF% _____ IMP. DIA _____

VERTIFLO PUMP COMPANY Performance Curves

Curve KL-1915

Series 600
 Size 2 X 1 1/2 X 12
 RPM 1750
 Max Sphere 7/16

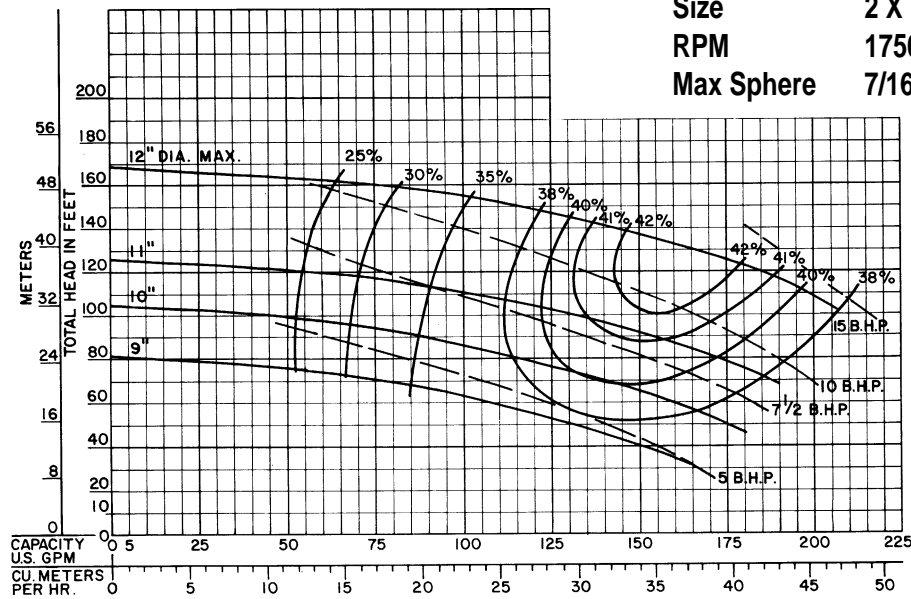

Curve LL-1915

Series 600
 Size 2 X 1 1/2 X 12
 RPM 1150
 Max Sphere 7/16

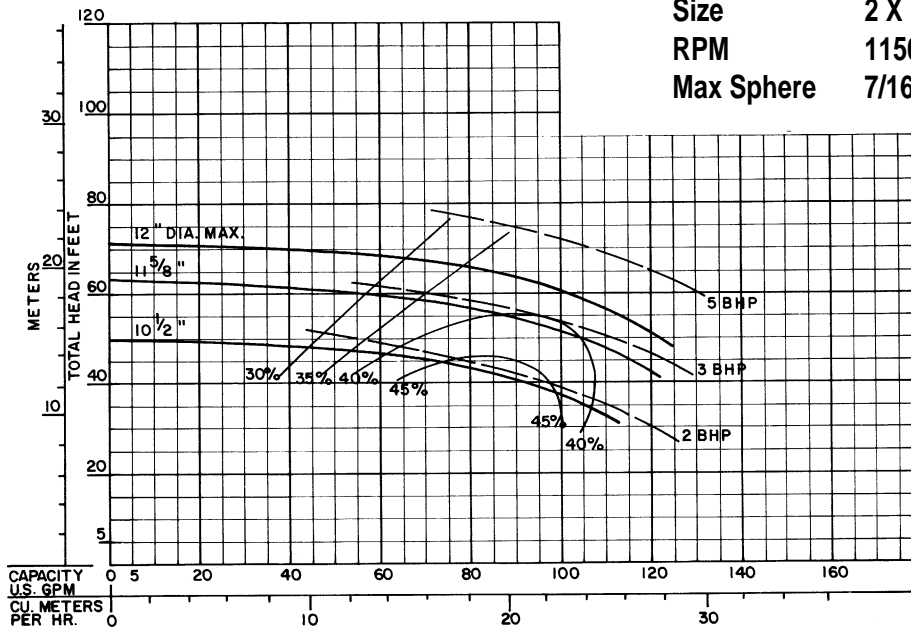

Performance at Casing Discharge Flange

Curves Show Performance with Liquid Having Specific Gravity 1.0 Viscosity • 30 SSU

CUSTOMER _____ CUSTOMER NO. _____

PROJECT _____

ENGINEER _____

CONTRACTOR _____

CONDITIONS: _____ GPM _____ TDH _____ HP _____ EFF% _____ IMP. DIA _____

VERTIFLO PUMP COMPANY Performance Curves

Curve KL-1916

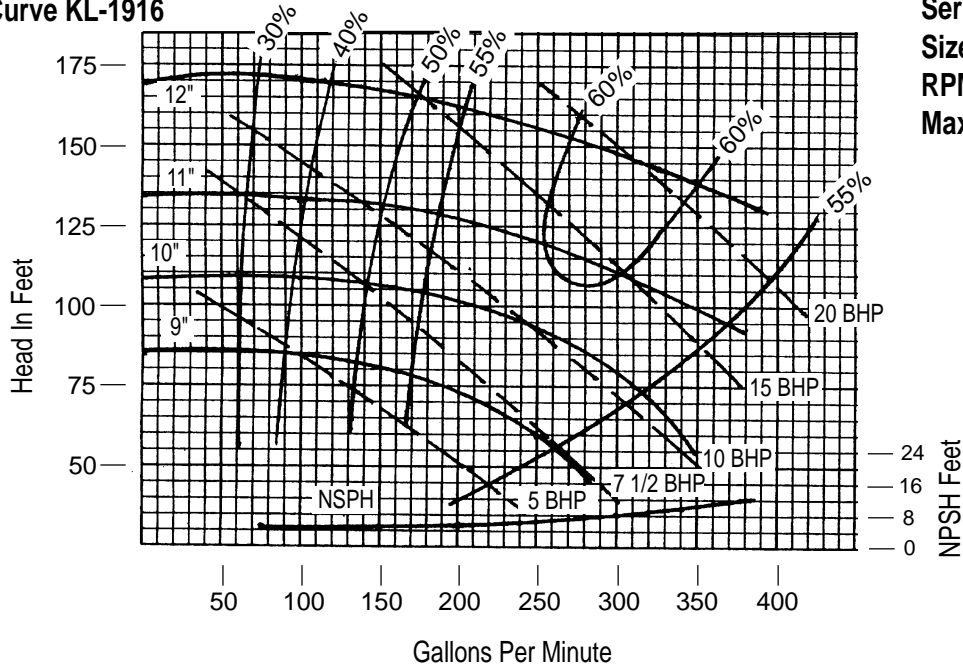

Curve LL-1916

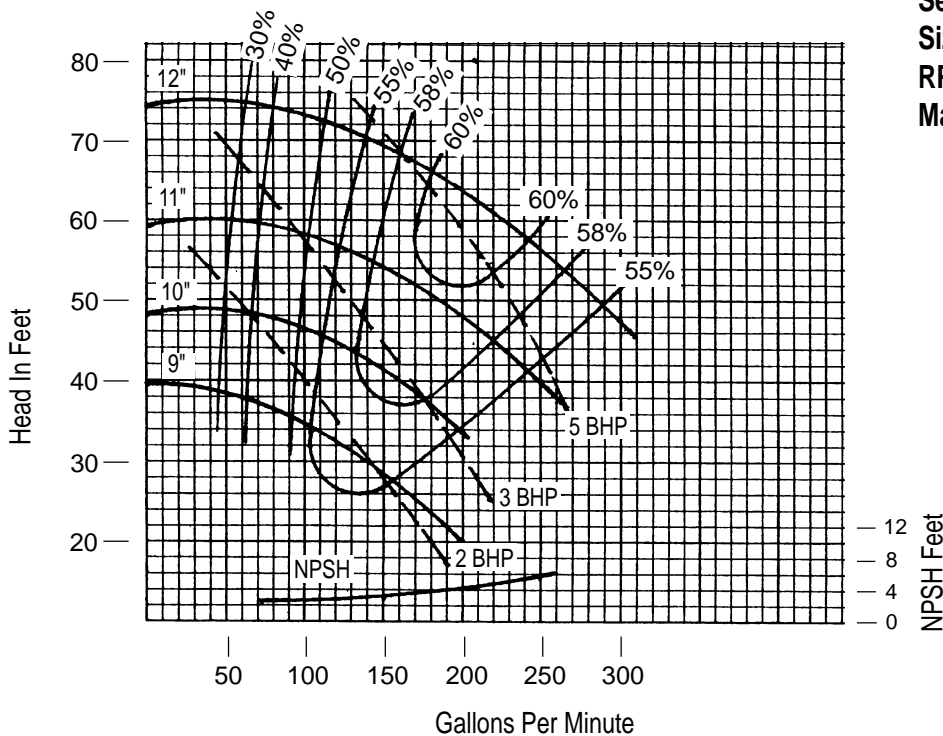

Performance at Casing Discharge Flange

Curves Show Performance with Liquid Having Specific Gravity 1.0 Viscosity • 30 SSU

CUSTOMER _____ CUSTOMER NO. _____

PROJECT _____

ENGINEER _____

CONTRACTOR _____

CONDITIONS: _____ GPM _____ TDH _____ HP _____ EFF% _____ IMP. DIA _____

VERTIFLO PUMP COMPANY Performance Curves

Curve KL-1917

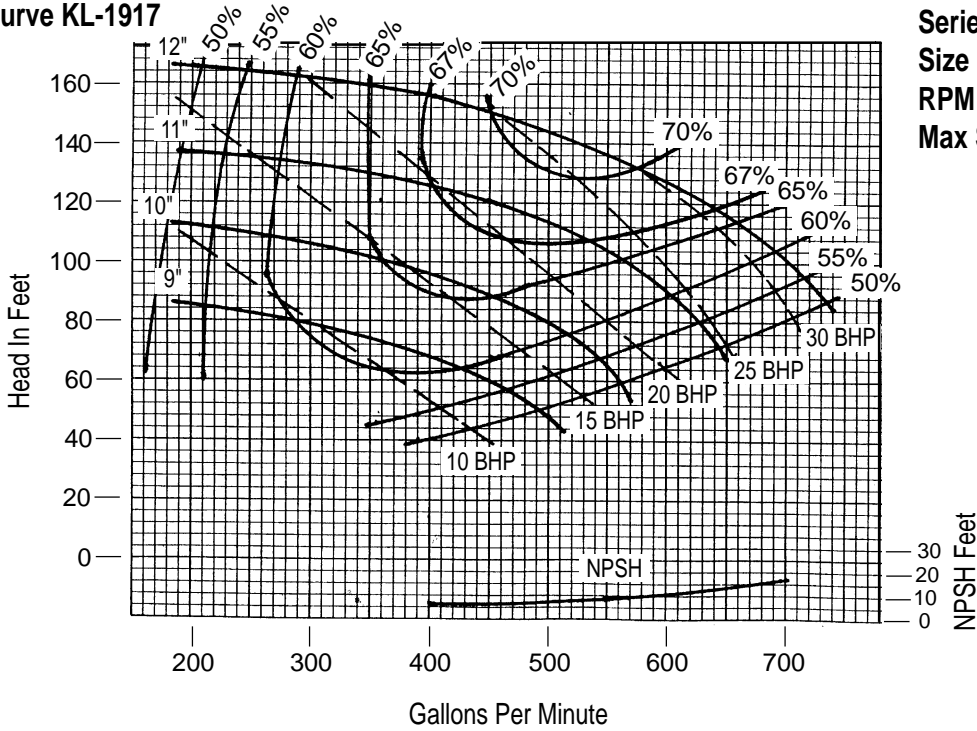

Series 600
 Size 4 X 3 X 12
 RPM 1750
 Max Sphere 1 1/4

Curve LL-1917

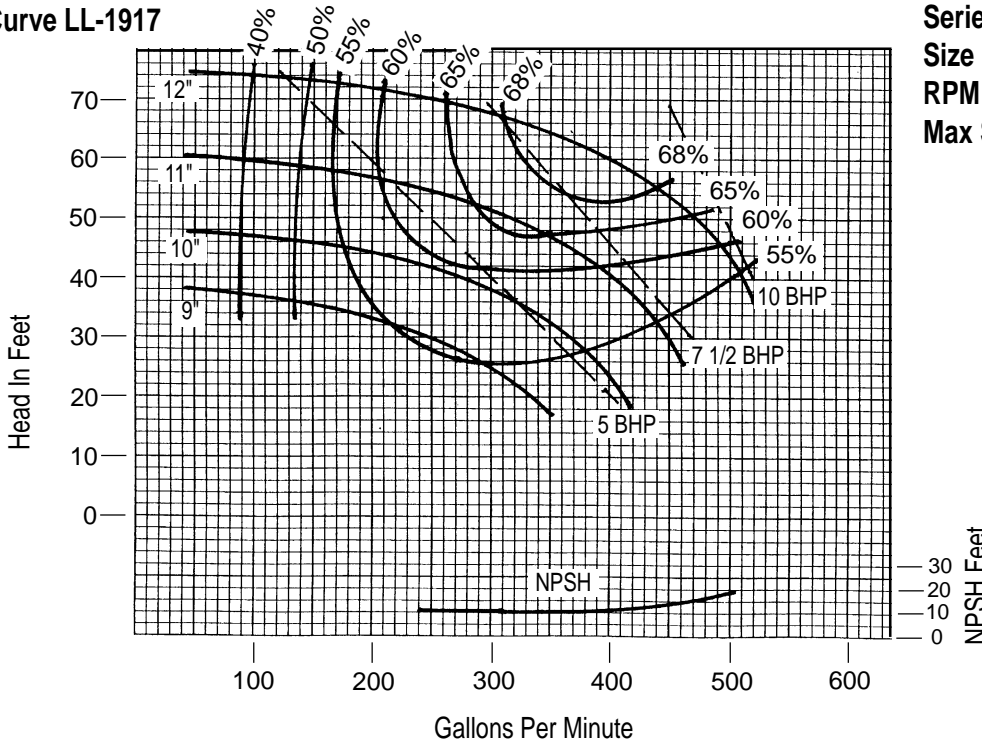

Series 600
 Size 4 X 3 X 12
 RPM 1150
 Max Sphere 1 1/4

Performance at Casing Discharge Flange

Curves Show Performance with Liquid Having Specific Gravity 1.0 Viscosity • 30 SSU

CUSTOMER _____ CUSTOMER NO. _____

PROJECT _____

ENGINEER _____

CONTRACTOR _____

CONDITIONS: _____ GPM _____ TDH _____ HP _____ EFF% _____ IMP. DIA _____

VERTIFLO PUMP COMPANY Performance Curves

Curve 64124

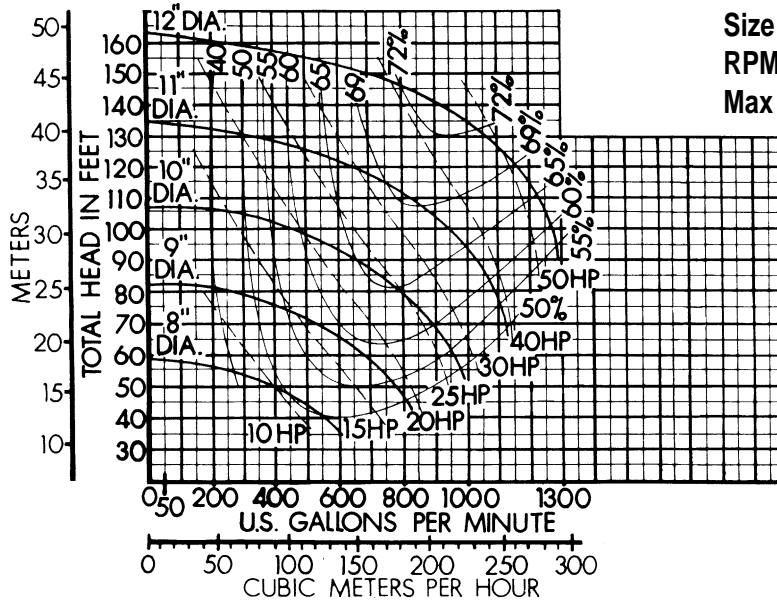

Series 600
 Size 6 X 4 X 12
 RPM 1750
 Max Sphere 1 1/2

Curve 64126

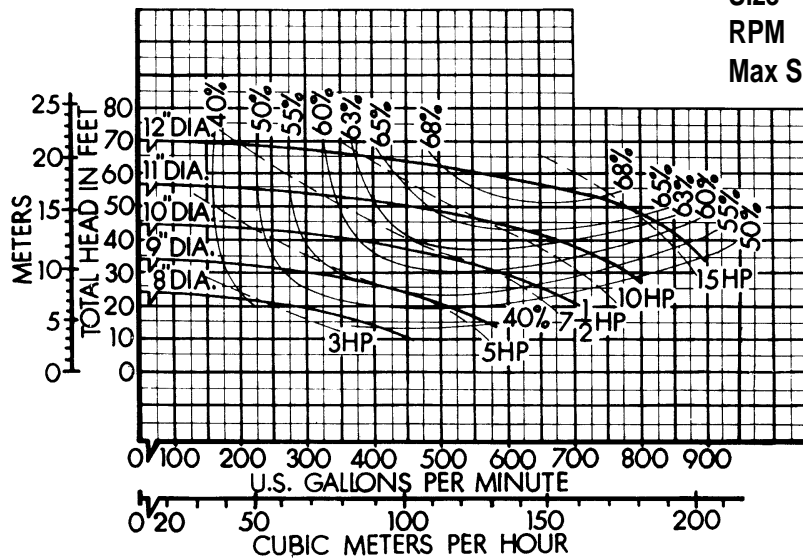

Series 600
 Size 6 X 4 X 12
 RPM 1150
 Max Sphere 1 1/2

600

Performance at Casing Discharge Flange
 Curves Show Performance with Liquid Having Specific Gravity 1.0 Viscosity • 30 SSU

CUSTOMER _____ CUSTOMER NO. _____
 PROJECT _____
 ENGINEER _____
 CONTRACTOR _____
 CONDITIONS: _____ GPM _____ TDH _____ HP _____ EFF% _____ IMP. DIA _____

VERTIFLO PUMP COMPANY Performance Curves

Curve 6412A4

Series 600
 Size 6 X 4 X 12A
 RPM 1750
 Max Sphere 1 1/8

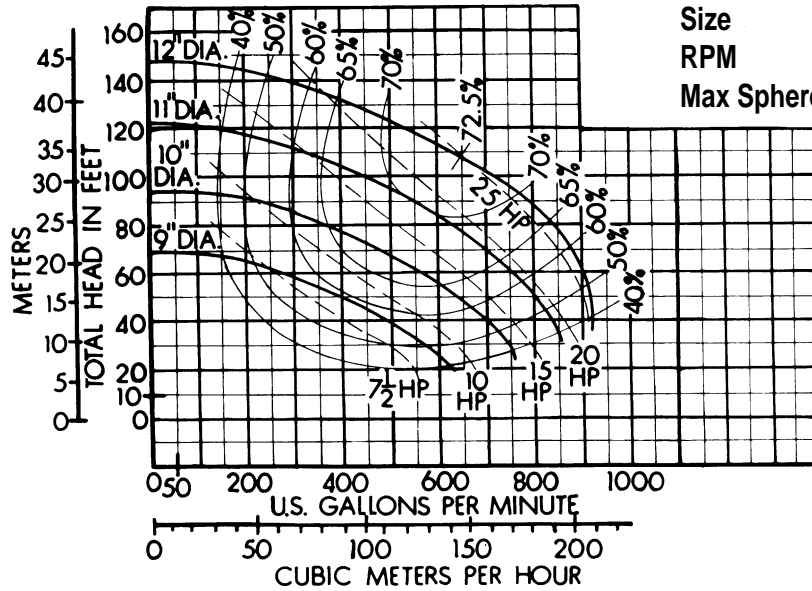

Curve 6412A6

Series 600
 Size 6 X 4 X 12A
 RPM 1150
 Max Sphere 1 1/8

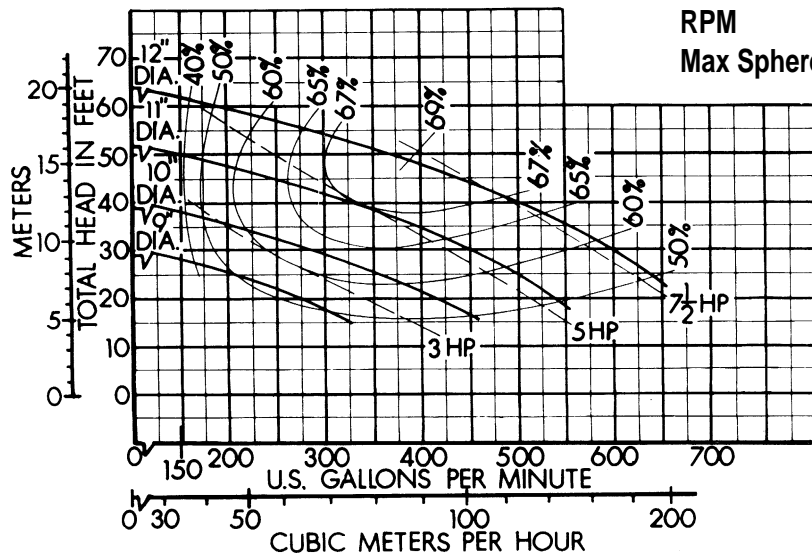

Performance at Casing Discharge Flange

Curves Show Performance with Liquid Having Specific Gravity 1.0 Viscosity • 30 SSU

CUSTOMER _____ CUSTOMER NO. _____

PROJECT _____

ENGINEER _____

CONTRACTOR _____

CONDITIONS: _____ GPM _____ TDH _____ HP _____ EFF% _____ IMP. DIA _____

VERTIFLO PUMP COMPANY Performance Curves

Curve 66124

Series 600
 Size 6 X 6 X 12
 RPM 1750
 Max Sphere 1 1/2

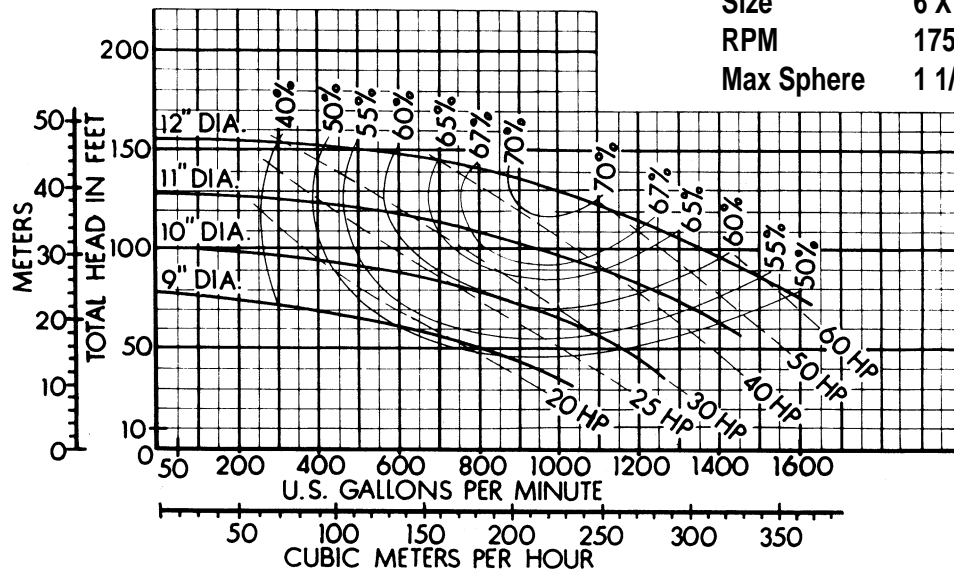

Curve 66126

Series 600
 Size 6 X 6 X 12
 RPM 1150
 Max Sphere 1 1/2

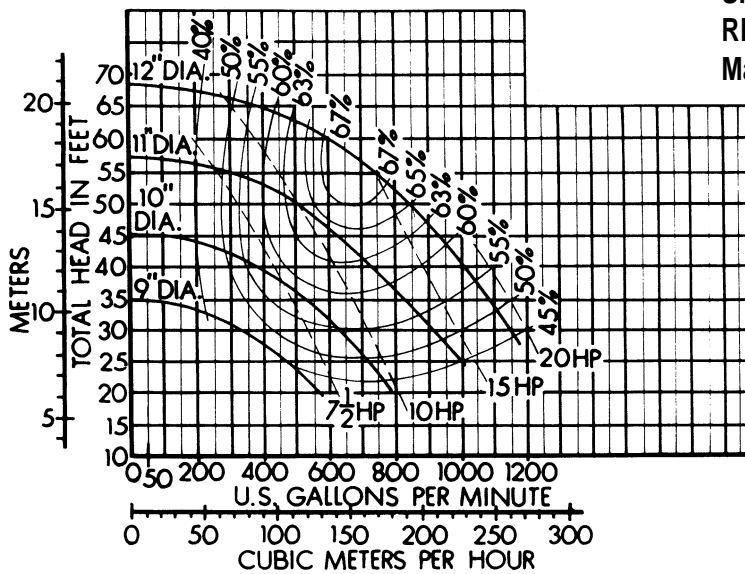

Performance at Casing Discharge Flange

Curves Show Performance with Liquid Having Specific Gravity 1.0 Viscosity • 30 SSU

CUSTOMER _____ CUSTOMER NO. _____

PROJECT _____

ENGINEER _____

CONTRACTOR _____

CONDITIONS: _____ GPM _____ TDH _____ HP _____ EFF% _____ IMP. DIA _____

600

VERTIFLO PUMP COMPANY Performance Curves

Curve 88124

Series 600
 Size 8 X 8 X 12
 RPM 1750
 Max Sphere 1 1/2

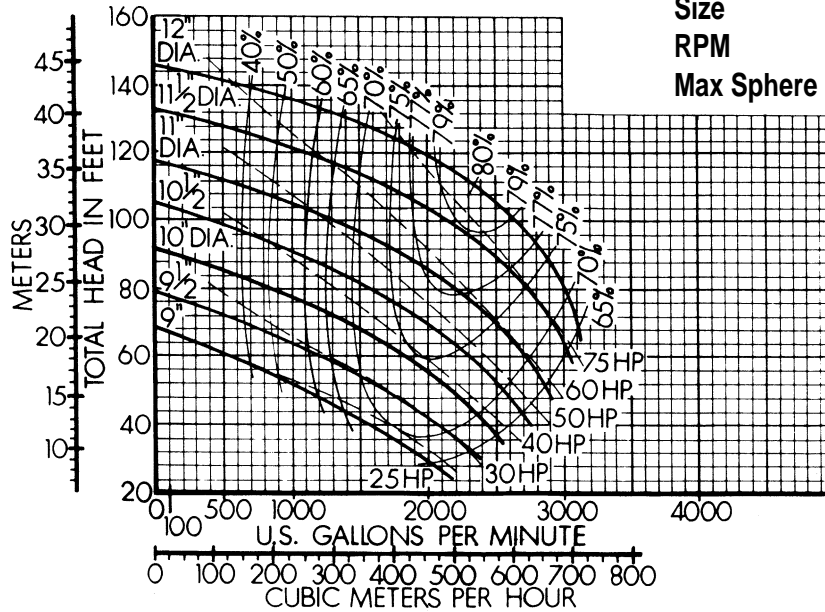

Curve 88126

Series 600
 Size 8 X 8 X 12
 RPM 1150
 Max Sphere 1 1/2

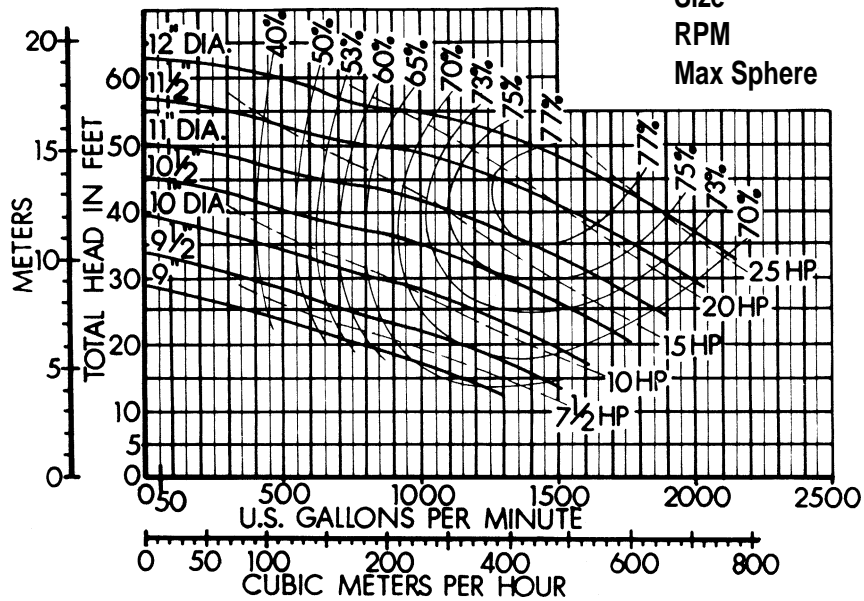

Performance at Casing Discharge Flange
 Curves Show Performance with Liquid Having Specific Gravity 1.0 Viscosity • 30 SSU

CUSTOMER _____ CUSTOMER NO. _____
 PROJECT _____
 ENGINEER _____
 CONTRACTOR _____
 CONDITIONS: _____ GPM _____ TDH _____ HP _____ EFF% _____ IMP. DIA _____

629 - TCD Process Pump "C" Face Motor w/Discharge Pipe

PUMP DATA

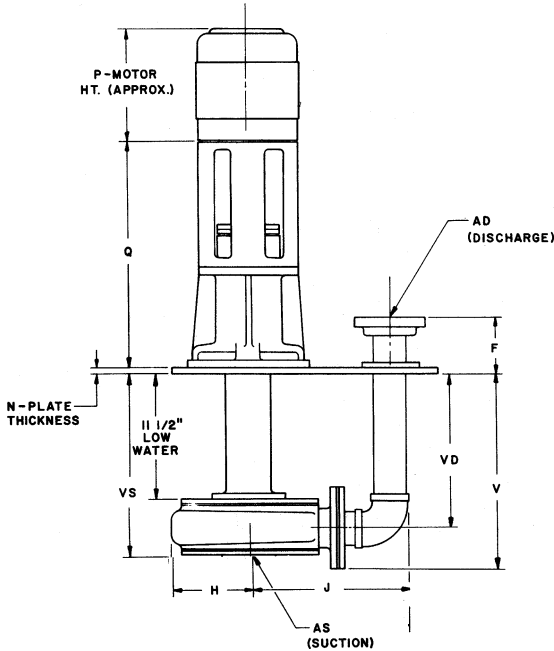

SIZE	(1) AD	(1) AS	B	D	E ₁	EE ₁	(4) F	(4) H	(4) J	(4) L	M	N	O ₁	O ₂	(3) (2) V	(3) (2) VD	(3) (2) VS	C
3x2½x7	2½ 3	3	18	26	8	12	4 5	5½	13½ 14½	11½ 12	3⅞ 4⅞	½	6	5⅞	17⅞	14½	16½	7¼ 7⅞
1½x1x8	1 1½	1½	18	26	8	12	3½ 4	5¼	11½ 11⅞	9⅞ 10⅞	3¼ 3⅞	½	5½	5¼	15¾	13⅞	15¼	6⅞ 6½
1½x1¼x8	1½ 2	1½	18	26	8	12	3½ 4	5½	11¼ 11⅞	10 10⅞	3¼ 3⅞	½	5½	5¼	16	13⅞	15½	6⅞ 7
2x1½x8	2 2	2	18	26	8	12	4 4	5½	11¼ 11⅞	10 10⅞	3¼ 3⅞	½	5½	5¼	16½	13⅞	15¾	6⅞ 7
3x2x8	2 3	2½	18	26	8	12	4 4	5⅞	12⅞ 14⅞	11⅞ 11⅞	3⅞ 4⅞	½	6¼	5½	16¾	13¾	16	7¾
4x3x8	3 4	4	18	26	8	12	5 4½	6⅞	15⅞ 16⅞	13⅞ 13⅞	6⅞ 6⅞	½	6⅞	5¾	17⅞	14⅞	16⅞	7¼
5x4x8	4 5	5	21	30	9½	14	5½ 5½	7¼	17¼ 18⅞	14½ 15	5¾ 6¼	½	8¼	6⅞	18⅞	14⅞	17¼	8¾
2x1½x10	1½ 2	2	18	26	8	12	3½ 4	6⅞	12½ 13	11¼ 11½	3½ 3¾	½	6¾	6⅞	16½	13⅞	15⅞	7¾
3x2x10	2 3	3	18	26	8	12	4 4	6⅞	13⅞ 15½	12⅞ 12⅞	4⅞ 5⅞	½	7¼	6½	16¾	13¾	16	7¾
4x3x10	3 4	4	21	30	9½	14	5 4½	7¼	17¼ 18¼	15 15½	6½ 7	½	7¾	6⅞	17¾	14	16½	8½
5x4x10	4 5	5	24	36	11	17	5½ 5½	7¾	19¼ 20⅞	16½ 17	7¼ 7¾	¾	8¾	7	18¾	14¼	17	9¼
6x5x10	5	6	24	36	11	17	5½	8⅞	20⅞	17½	8¼	¾	9¾	7½	19¼	14¼	17⅞	9¼
6x5x10 _A	6	6	24	36	11	17	5½	8⅞	22	18	8¾	¾	9¾	7½	19¼	14¼	17⅞	9¼
6x6x10	6	6	28	42	13	20	5½	10¼	22½	18½	8⅞	¾	11⅞	8¾	20	14½	17⅞	10⅞
6x6x10 _A	8	6	28	42	13	20	5½	10¼	25	19⅞	8¾	¾	11⅞	8¾	20	14½	17⅞	10⅞
2x1½x12	1½ 2	2	20	26	9	12	3½ 4	8	13⅞ 14½	12⅞ 13	3½ 3⅞	½	8¾	7⅞	16	13½	17¼	9⅞ 9⅞

- (1) ALL FLANGES ARE 125" ANSI
- (2) ALL DIMENSIONS FOR 12" EXTENSION
ADD 3" TO "V" DIMENSION FOR 15" EXTENSION
- (3) ADD 9" TO "V" DIMENSION FOR 21" EXTENSION
- (4) VARIES DUE TO THREADED FITTINGS

MOTOR DATA

FRAME	P	Q
56 C	12½	18⅞
143 TC	12½	18⅞
145 TC	12½	18⅞
182-184 TC	13½	20½
213 TC	15½	20½
215 TC	17	20½
254 TC	20⅞	20½
256 TC	21⅞	20½
284 TC	22⅞	21¼
286 TC	23⅞	21¼
324 TC	24¾	21¾
326 TC	26⅞	21¾
364 TC	26½	22⅞
365 TC	27½	22⅞

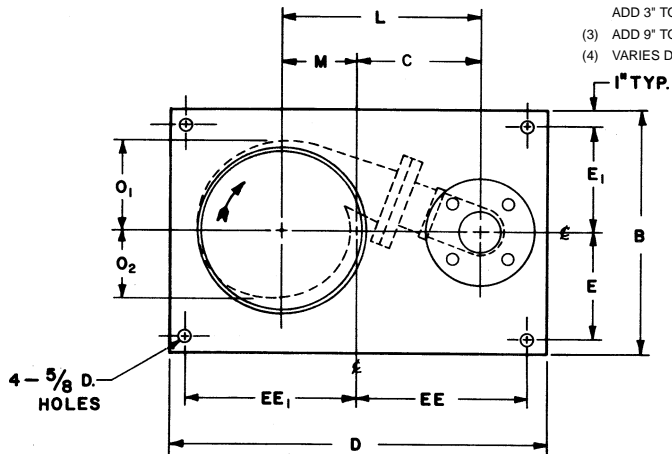

Not for construction unless certified, some dimensions may vary ± 1/2". Pump Construction: _____

CUSTOMER _____ CUSTOMER NO. _____
 PROJECT _____ SERIAL NO. _____
 ENGINEER _____ LOCATION _____
 CONTRACTOR _____
 PUMP Model Size Curve No. GPM Head SP. GR. @Temp. Pump Length Plate
 DATA _____
 MOTOR Mfgr. HP RPM Volt-Phase-Cycle Frame ENC. Furnished by Mounted by
 DATA _____
 Shop Order _____ Certified by _____ Date _____

VERTIFLO PUMP COMPANY Dimensions

636 - TCP Process Pump "C" Face Motor w/Discharge Pipe

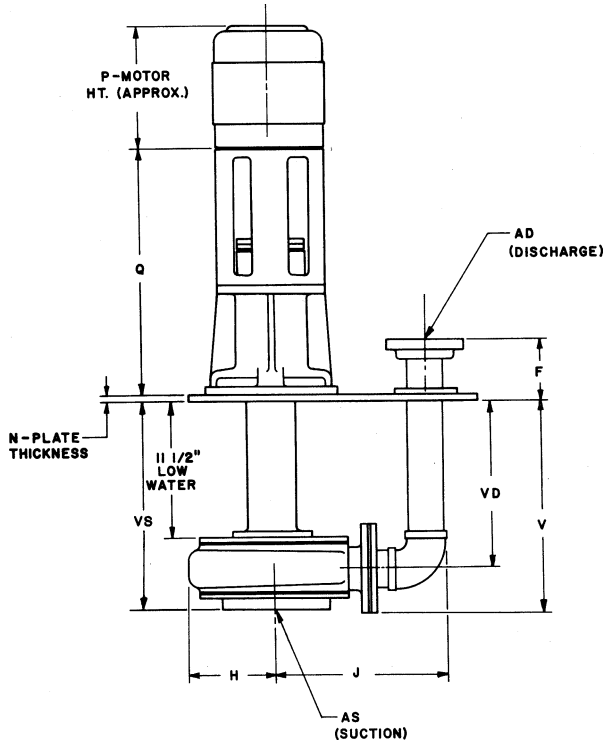

PUMP DATA

SIZE	3x2x12	4x3x12	6x4x12 6x4x12A	6x6x12	8x8x12
AD	2 3	3 4	4 5 6	6 8	8
C	10 1/2	10 1/2	11 7/8	12	15
AS	3	4	6	6	8
B	24	24	24	28	32
D	36	36	36	42	48
E ₁	11	11	12	14	17
E ₂	11	11	10	12	13
EE	17	17	17	20	23
⁽¹⁾ F	5	6	6	5 1/2	6 5/8
H	8	8 1/2	9 3/8	10 1/4	13
⁽¹⁾ J	15 3/4	17 1/4	18 19 17 3/4	21 22 22 3/4	25
⁽¹⁾ L	14 1/4 15	15 3/4 16 1/8	17 17 1/2 18	18 3/4 19 5/8	23
⁽¹⁾ M	3 3/4 4 1/2	5 1/4 5 5/8	5 5/8 5 5/8 6 1/8	6 3/4 7 5/8	8
N	5/8	5/8	5/8	5/8	5/8
O ₁	7 3/4	9	10	11	14 1/8
O ₂	8 3/8	8 1/8	8 5/8	9 1/2	11
V	17 17 1/4	17 1/4 18	18 1/8 18 1/8 19 1/8	19 3/8 20 5/8	20 7/8
VD	14	13 1/2	13 5/8	13 7/8	14 1/8
VS	16 1/4	15 7/8	16 3/8	17 1/8	18 5/8

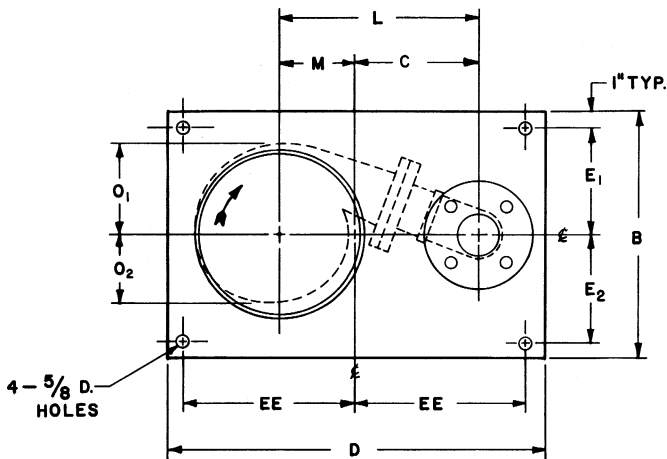

MOTOR DATA

FRAME	P	Q
56 C	12 1/2	20 1/2
143 TC	12 1/8	20 1/2
145 TC	12 1/2	20 1/2
182-184 TC	13 1/2	20 1/2
213 TC	15 1/2	20 1/2
215 TC	17	20 1/2
254 TC	20 1/8	20 1/2
256 TC	21 1/8	20 1/2
284 TC	22 3/8	21 1/4
286 TC	23 3/8	21 1/4
324 TC	24 3/4	21 3/4
326 TC	26 1/8	21 3/4
364 TC	26 1/2	22 3/8
365 TC	27 1/2	22 3/8

Not for construction unless certified, some dimensions may vary $\pm 1/2"$. Pump Construction: _____

CUSTOMER _____ CUSTOMER NO. _____
 PROJECT _____ SERIAL NO. _____
 ENGINEER _____ LOCATION _____
 CONTRACTOR _____
 PUMP Model _____ Size _____ Curve No. _____ GPM _____ Head _____ SP. GR. @Temp. _____ Pump Length _____ Plate
 DATA _____
 MOTOR Mfr. _____ HP _____ RPM _____ Volt-Phase-Cycle _____ Frame ENC. _____ Furnished by _____ Mounted by _____
 DATA _____
 Shop Order _____ Certified by _____ Date _____