

Ampco Centrifugal Pumps

Data Sheet

Model ZC2 2 1/2 x 2

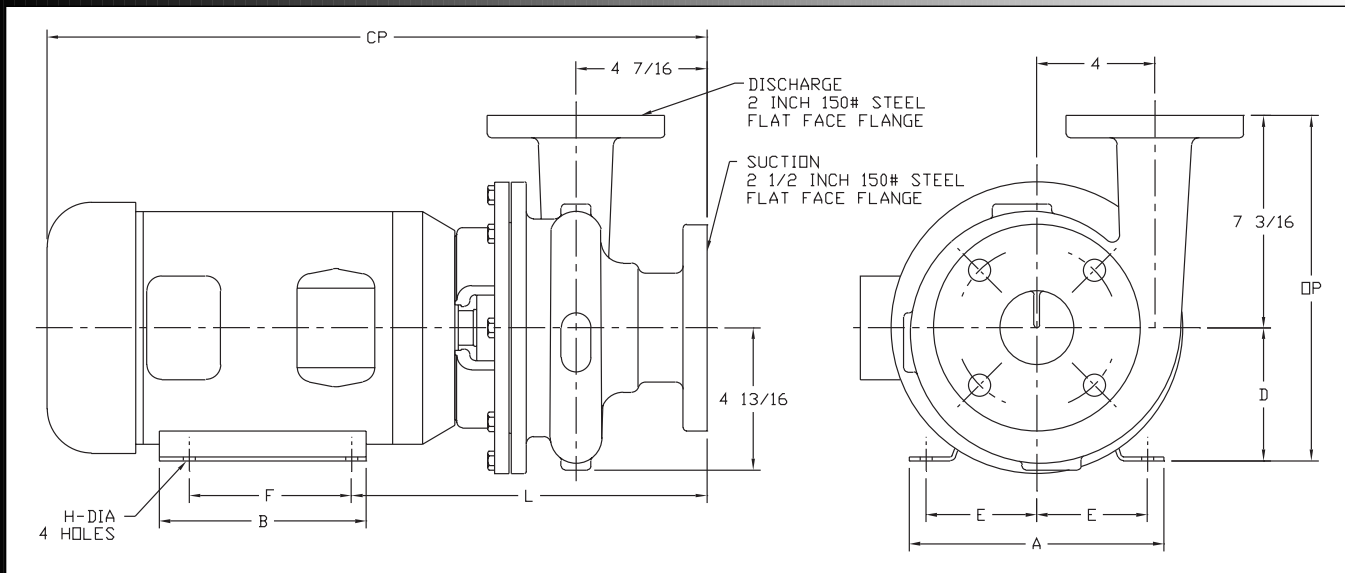

| TEFC MOTOR | | | DIMENSIONS IN INCHES (For Reference Only) | | | | | | | | | APPROX. WEIGHT (LBS) |
|------------|------|-------|---|---------|-------|-------|-------|-------|--------|----------|----------|----------------------|
| HP | RPM | FRAME | A (max) | B (max) | D | E | F | H | L | CP | OP | |
| 1 | 1750 | 143JM | 6-1/2 | 6 | 3-1/2 | 2-3/4 | 4 | 11/32 | 11-1/2 | 19-15/16 | 10-11/16 | 118 |
| 1-1/2 | 1750 | 145JM | 6-1/2 | 6 | 3-1/2 | 2-3/4 | 5 | 11/32 | 11-1/2 | 19-15/16 | 10-11/16 | 122 |
| 2 | 1750 | 145JM | 6-1/2 | 6 | 3-1/2 | 2-3/4 | 5 | 11/32 | 11-1/2 | 19-15/16 | 10-11/16 | 128 |
| 3 | 1750 | 182JM | 8-5/8 | 6-1/2 | 4-1/2 | 3-3/4 | 4-1/2 | 13/32 | 12-1/8 | 21-3/16 | 11-11/16 | 154 |
| 5 | 3500 | 184JM | 8-5/8 | 6-1/2 | 4-1/2 | 3-3/4 | 5-1/2 | 13/32 | 12-1/8 | 22-9/16 | 10-11/16 | 167 |
| 7-1/2 | 3500 | 213JM | 9-5/8 | 8-1/8 | 5-1/4 | 4-1/4 | 5-1/2 | 13/32 | 12-7/8 | 25-7/16 | 12-7/16 | 235 |
| 10 | 3500 | 215JM | 9-5/8 | 8-1/8 | 5-1/4 | 4-1/4 | 7 | 13/32 | 12-7/8 | 25-7/16 | 12-7/16 | 253 |
| 15 | 3500 | 215JM | 9-1/2 | 8 | 5-1/4 | 4-1/4 | 7 | 13/32 | 13-1/8 | 25-9/16 | 12-7/16 | 211 |

MATERIAL SPECIFICATIONS

| PART NAME | NICKEL ALUMINUM BRONZE | STAINLESS STEEL |
|--------------------------|------------------------|-----------------|
| Casing, Cover & Impeller | AMPCO® 483 | 316 Stainless |
| Wear Ring | AMPCO® 18 | 316 Stainless |
| Motor Shaft | Steel | Steel |
| Shaft Sleeve | AMPCO® 18 | 316 Stainless |
| Adapter | Cast Iron | Cast Iron |

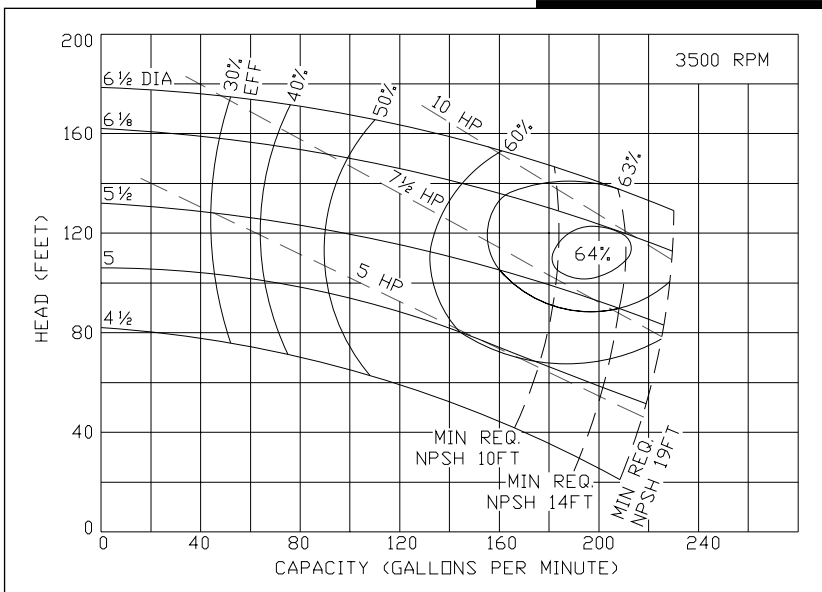
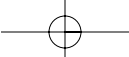

Ampco Centrifugal Pumps

Model ZC2 2 1/2 x 2

Curves show approximate characteristics based on clear 68° water. Rated point is guaranteed.

Heavy-duty Z Series pumps have maximum wall thickness and 150 lb. flat faced flanged connections.

Seal options include Type 21, Type 1 and Type 9 with choice of sealing materials.

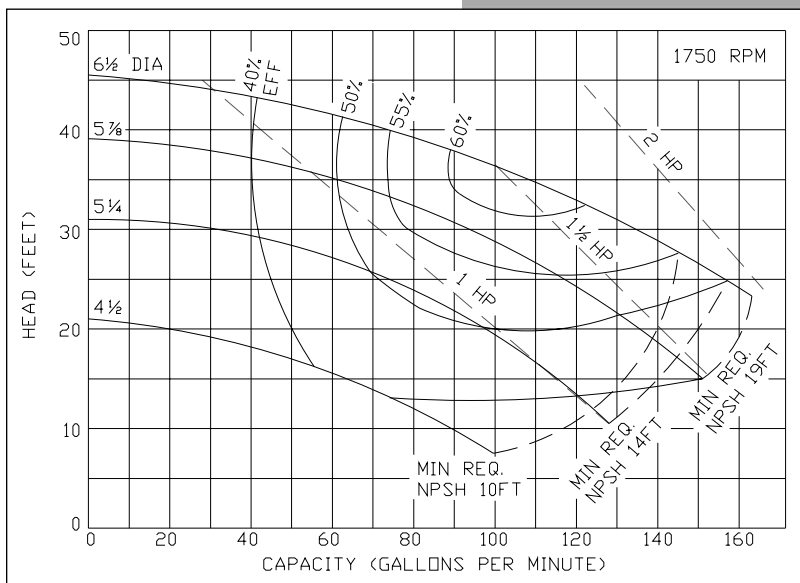
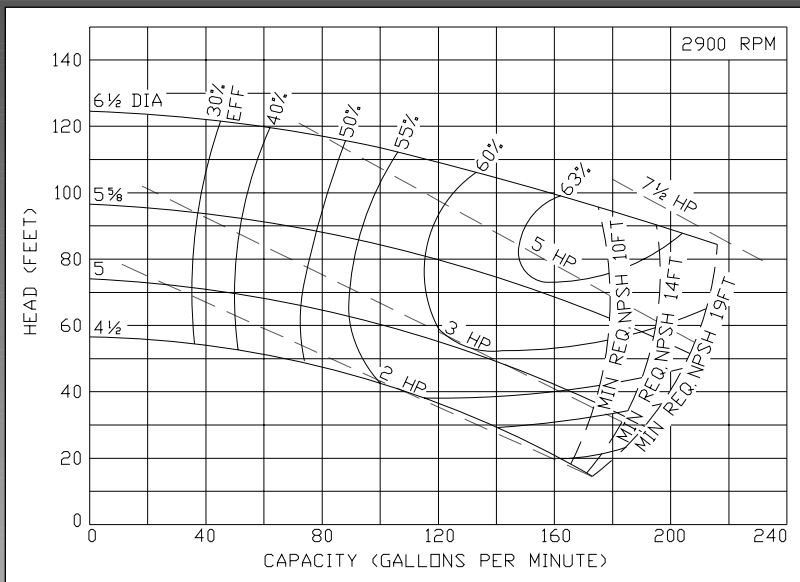

Ampco Pumps Company

4424 West Mitchell Street
 Milwaukee, Wisconsin 53214
 PHONE (414) 643-1852
 FAX (414) 643-4452

