

Size 1 1/2" x 1 1/2"

Models 11 1/2A2—GX120

**COMPETITIVE
PUMP** 
PRODUCTS BY
GORMAN-RUPP 



PUMP SPECIFICATIONS

Size: 1-1/2" x 1-1/2" (38 mm x 38 mm) NPT - Female.

Casing: Gray Iron.

Maximum Operating Pressure 69 psi (476 kPa).*

Semi-Open Type, Two Vane Impeller: Gray Iron.

Handles 1" (25,4 mm) Diameter Spherical Solids.

Replaceable Wear Plate: Carbon Steel.

Intermediate Bracket: Gray Iron.

Seal: Double, Grease-Lubricated with Spring Loaded Grease Cup. Sintered Bronze Stationary Seal Seats. Steel Rotating Faces. Neoprene Packing Rings. Maximum Temperature of Liquid Pumped, 110°F (43°C). Maximum Suction Pressure 10 psi (69 kPa).*

Seal Liner: Copper Alloy.

Flap Valve: Steel, Gray Iron and Buna-N ^w/Nylon Reinforcement.

Flange: Gray Iron.

Gaskets: Cork and Vegetable Fiber.

Hardware: Standard Plated Steel.

Standard Equipment: Roll Cage ^w/Rubber Feet. Strainer. Ductile Iron 90° Discharge Elbow.

**Consult Factory for Applications Exceeding Maximum Pressure and/or Temperature Indicated.*

WARNING!

Do not use in explosive atmosphere or for pumping volatile flammable liquids.

ENGINE SPECIFICATIONS

Model: Honda GX120

Type: Air Cooled, Gasoline Engine.

Fuel Tank: 2.1 U.S. Qts. (2,0 liter).

Full Load Operating Time: 3 Hrs.

Starter: Rope Rewind.

Standard Equipment: Muffler ^w/Guard. Oil Alert Low Oil Shutdown.

**COMPETITIVE
PUMP** 
PRODUCTS BY
GORMAN-RUPP 

GORMAN-RUPP OF CANADA LIMITED
ST. THOMAS, ONTARIO

www.grcanada.com

Specifications Subject to Change Without Notice

Printed in Canada.

Specification Data

APPROXIMATE
DIMENSIONS and WEIGHTS

NET WEIGHT: 90 LBS. (40,8 KG.)
SHIPPING WEIGHT: 100 LBS. (45,3 KG.)
WHEEL KIT ADD 25 LBS. (11.3 KG.);
SHIPPING CRATE (SEPARATE) 3 CU. FT. (0,08 CU. M.)

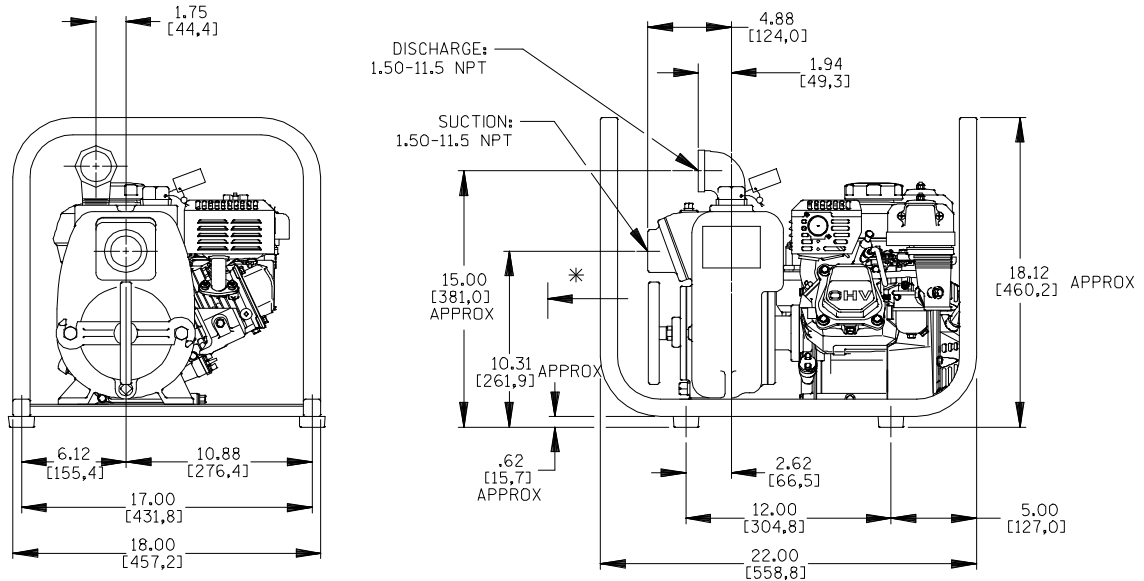

POWERED BY HONDA GX120 ENGINE

DIMENSIONS:
INCHES
[MILLIMETERS]

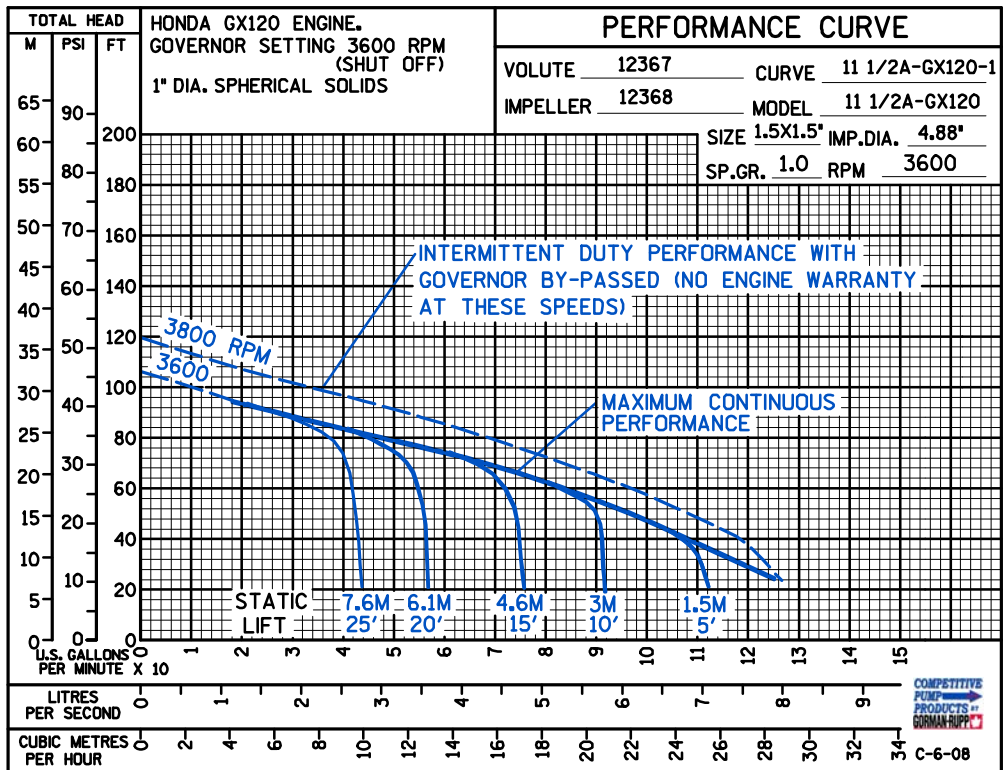

GORMAN-RUPP OF CANADA LIMITED
ST. THOMAS, ONTARIO

www.grcanada.com

Specifications Subject to Change Without Notice

Printed in Canada.